



LX Wireless System

READ ME FIRST!

To get your system up and running in just a few minutes, follow the simple instructions on this page. For more detailed information, refer to the sections of this guide that apply to your system.

RECEIVER CONNECTIONS

1. Attach the antennas to the receiver antenna connectors.
2. Connect the AC power adapter to the receiver power connector; then plug it into an ac electrical outlet.
3. Connect the receiver audio output to the sound system, using either a low- or high-impedance audio cable.

TRANSMITTER CONNECTIONS

1. Open the transmitter battery compartment and insert a fresh 9-volt alkaline battery. Observe proper battery polarity (“+/-”).
2. If you are using a body-pack transmitter, connect the microphone or WA302 instrument cable to the 4-pin connector on the transmitter.

OPERATING THE SYSTEM

1. Press the receiver POWER switch. The green POWER light on the receiver illuminates.
2. Set the transmitter PWR/OFF switch to PWR and the ON/MUTE switch to ON. One of the three lights on the transmitter illuminates, indicating both that the transmitter is on and the amount of battery life remaining. Two sets of five RF level lights on the receiver will also glow to indicate the strength of the received signal. The more lights glowing, the stronger the signal.
3. Have someone talk or sing into the microphone, or play the musical instrument connected to the transmitter. The audio level will be indicated as follows:
 - Green lights (3) glowing indicates normal operation.
 - Amber light glowing indicates approaching audio overload (should only occur during loud signals).
 - Red light glowing steadily indicates audio overload. If this happens, reduce the transmitter gain until it flickers only during the loudest signals. Refer to the Transmitter Audio Gain Adjustment section of this guide.
4. Adjust the receiver LEVEL control until the output level is compatible with the mixer or amplifier input. In most cases, this control should be set fully clockwise.

YOU ARE NOW READY TO PERFORM!

IMPORTANT: Every wireless microphone installation is a unique situation, and can present a variety of problems. Never attempt a live performance without first conducting a “walkthrough” test of the system in the performing area. If major changes (additional wireless systems or intercoms, relocation of scenery, etc.) have been made since the last walk-through test, check the wireless system again-as close to performance time as possible.

TABLE OF CONTENTS

TABLE OF CONTENTS	2
SYSTEM COMPONENTS	3
SYSTEM FEATURES	4
LX1 BODY-PACK TRANSMITTER FEATURES, CONTROLS AND INDICATORS	5
LX2 HANDHELD MICROPHONE-TRANSMITTER FEATURES, CONTROLS AND INDICATORS	6
LX3 RECEIVER FEATURES, CONTROLS AND INDICATORS	7
LX4 DIVERSITY RECEIVER FEATURES, CONTROLS AND INDICATORS	8
RECEIVER MOUNTING	9
RECEIVER CONNECTIONS	10
TRANSMITTER SETUP	11
OPERATING LX1 BODY-PACK SYSTEMS	14
OPERATING THE LX2 HAND-HELD SYSTEM	15
GAIN AND SQUELCH ADJUSTMENT	16
TIPS FOR ACHIEVING OPTIMUM PERFORMANCE	17
TROUBLESHOOTING	18
SPECIFICATIONS	19
LICENSING INFORMATION	22

SYSTEM COMPONENTS

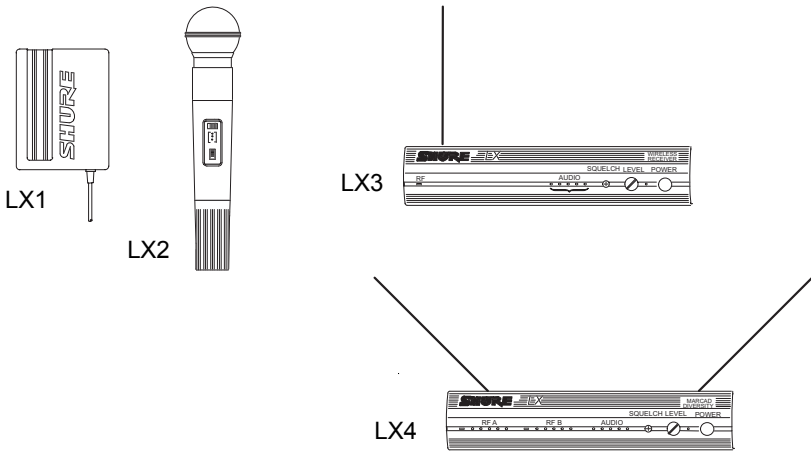

LX WIRELESS MICROPHONE SYSTEM COMPONENTS
FIGURE 1

Your LX Wireless Microphone System features a MARCAD® fixed frequency diversity receiver operating in the VHF band between 169 and 240 MHz. Up to 12 LX wireless systems can be operated simultaneously in a single installation. Each LX system includes:

- **LX1** Body-Pack Transmitter, with your choice of instrument cable or microphone,

or

- **LX2** Hand-Held Microphone-Transmitter with your choice of interchangeable microphone heads:
 - SM58® cardioid dynamic microphone
 - BETA 58® supercardioid premium dynamic microphone
 - SM87 supercardioid condenser microphone
 - BETA 87 supercardioid premium condenser microphone

and one of the following half-rack size receivers:

- **LX3** Receiver

or

- **LX4** Diversity Receiver
 - Both single and dual rack-mounting hardware
 - One antenna (LX3 systems) or two antennas (LX4 systems)
 - One of the following ac power adapters: **PS40**, **PS40E**, or **PS40UK**.

SYSTEM FEATURES

Shure LX Wireless Systems offer a number of exceptional features, including:

- **Exclusive Shure MARCAD Circuitry (LX4).** MARCAD (MAXimum Ratio Combining Audio Diversity) circuitry constantly monitors signals from both receiver sections and combines them to create a single output signal. The result is improved reception and exceptional freedom from dropouts.
- **Half-Rack Receiver Size.** The LX3 and LX4 receivers interface with the HR (half-rack) format, and are supplied with both single and dual rack-mount hardware. An optional WA503 accessory kit lets you front-mount antennas.
- **Power/Battery Fuel Gauge.** The LX1 and LX2 transmitters include a three-light gauge that indicates both “power on” and the amount of battery life remaining (see page 12).
- **Dual RF Level Meters (LX4).** Instead of a conventional single RF meter, the LX4 receiver has two meters, one for each antenna. The dual meters indicate received signal strength at each antenna, and make it easier to identify and troubleshoot RF “dead spots.”
- **Audio Metering.** A five-light audio meter helps to optimize transmitter gain setting and lets you monitor audio level during operation.
- **True Guitar Sound.** Guitar players demanding the highest degree of sound quality and reliability will appreciate the low noise and uncolored sound of the LX Wireless System.
- **Noise Squelch.** This circuit analyzes signal *quality* instead of signal *strength*. This virtually eliminates the possibility of annoying noise bursts coming through your receiver.
- **Body-Pack Transmitter Belt Clip.** The belt clip has a wider contact surface for a better grip, and firmly holds thinner, more slippery materials. It can be removed or inverted for special positioning.
- **Grip/Switch Cover Accessory.** The unbreakable WA555 grip/switch cover accessory, supplied with all LX2 hand-held microphone-transmitters, prevents accidental movement of the power and mute switches and provides a “grip” feel.
- **Compact Power Adapter.** The supplied ac power adapter incorporates small, in-line transformers that save space on ac power strips. It also has mounting tabs so it can be secured to any surface, as well as locking dc power connectors to prevent accidental disconnection from the receiver.

LX1 BODY-PACK TRANSMITTER FEATURES, CONTROLS AND INDICATORS

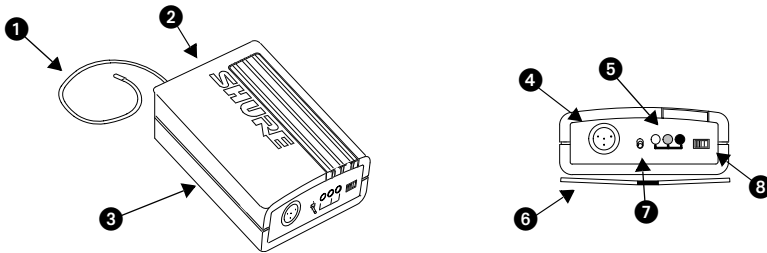

LX1 BODY-PACK TRANSMITTER FEATURES, CONTROLS AND INDICATORS
FIGURE 2

- ❶ **Antenna.** A flexible wire antenna is permanently attached to the bottom of the LX1 body-pack transmitter. *For best operation, the antenna **must** hang in the vertical position, and should **not** be coiled or bundled.*
- ❷ **Battery Compartment.** Hinged cover on bottom surface exposes the battery. Refer to the *Body-Pack Transmitter Battery Installation* section.
- ❸ **Audio Gain Control.** Allows audio level adjustment to accommodate various sound sources (e.g., singing, speaking, or playing an instrument). A small screwdriver is supplied to make adjustments (see the *Setting Audio Level* section).
- ❹ **Input Jack.** This is a Mini- connector (TA4F) that provides connection with a variety of lavalier and headset microphone cables, and the Shure WA302 instrument adapter cable.
- ❺ **Power/Battery Fuel Gauge.** When the Power switch is turned to the PWR position, one or two of the three lights on the transmitter illuminates, indicating power to the unit. The color of the glowing light(s) indicates the amount of battery life remaining (see page 12).
- ❻ **Belt Clip.** Allows the transmitter to be easily worn on a belt, waistband or guitar strap.
- ❼ **Mic On/Mute Switch.** “Mutes” the transmitter to prevent unwanted sounds from being picked up by the receiver *without* turning the transmitter off.
- ❽ **Power Switch.** Turns transmitter power on and off.

LX2 HANDHELD MICROPHONE-TRANSMITTER FEATURES, CONTROLS AND INDICATORS

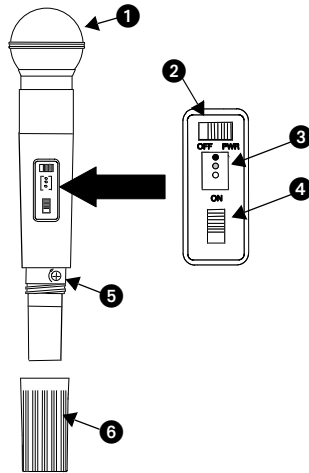

LX2 MICROPHONE-TRANSMITTER FEATURES, CONTROLS, AND INDICATORS

FIGURE 3

- 1 Grille.** Protects the microphone cartridge and helps reduce breath sounds and wind noise. The grilles for the various microphone heads differ in appearance.
- 2 Power Switch.** Turns transmitter power on and off.
- 3 Power/Battery Fuel Gauge.** When the Power switch is turned to the PWR position, one or two of the three lights on the transmitter illuminates. The color of the glowing light(s) indicates the amount of battery life remaining (see page 12).
- 4 Mic On/Mute Switch.** “Mutes” the transmitter to prevent unwanted sounds from being picked up by the receiver *without* turning the transmitter off.
- 5 Audio Gain Control.** Provides audio level adjustment to accommodate different sound sources (see page 16).
- 6 Battery Cover.** Removable cup hides battery and audio gain control.

LX3 RECEIVER FEATURES, CONTROLS AND INDICATORS

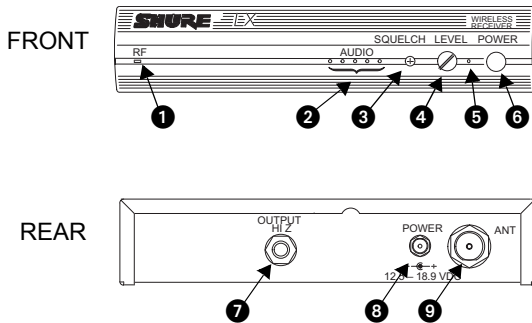

LX3 RECEIVER CONTROLS, FEATURES, AND INDICATORS

FIGURE 4

- ❶ **RF Presence Indicators.** Glows amber when the antenna is receiving usable RF (radio frequency) signals.
- ❷ **Audio Level Indicators.** Five lights glow to indicate audio signal strength. Green lights indicate normal operation. An amber light indicates approaching overload condition. A red light indicates excessive audio levels.
- ❸ **Squelch Control.** Sets the point at which the receiver “mutes” when the transmitter signal becomes noisy, weak or fails. This control is factory-set at the 12 o'clock position to provide optimal operation in most applications.
- ❹ **Audio Output Level Control.** Lets you adjust output level to match the input level requirements of a mixer or amplifier. In most situations, this control should be set fully clockwise.
- ❺ **Power On Indicator.** This green light glows to indicate that the Power switch is on and power is applied to the receiver.
- ❻ **Power On/Off Button.** Turns the receiver on and off.
- ❼ **Output Connector.** Quarter-inch phone jack provides unbalanced auxiliary level (high-impedance) output.
- ❽ **Power Jack:** Accepts power from the supplied AC adapter, or from any filtered 15 to 18 Vdc (400 mA minimum) supply. It will also accept the dc power cord from a Shure WA405 Antenna Power/Distribution System.
- ❾ **Antenna Connector.** UHF-type connector provides connection to the supplied 1/4-wave antenna or to coax cable used with a remote antenna. They also provide connection to the optional Shure WA421 remote antenna cable kit used with optional WA380 telescoping and WA490 cable-type 1/2-wave antennas.

LX4 DIVERSITY RECEIVER FEATURES, CONTROLS AND INDICATORS

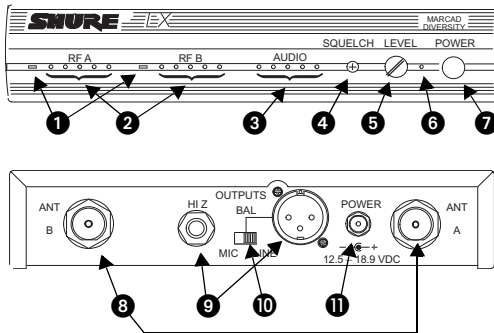

LX4 DIVERSITY RECEIVER FEATURES, CONTROLS AND INDICATORS
FIGURE 5

- ❶ **Diversity Signal Indicators for A and B Antennas.** These lights glow amber when A, B, or both antennas are receiving usable RF (radio frequency) signals.
- ❷ **RF Level Indicators.** Five lights per antenna glow to indicate RF signal strength. The more lights that glow, the stronger the received signal. If none of these lights glows, no signal is being received.
- ❸ **Audio Level Indicators.** Five lights glow to indicate audio signal strength. Green lights indicate normal operation. An amber light indicates approaching overload condition. A red light indicates excessive audio levels.
- ❹ **Squelch Control.** Sets the point at which the receiver “mutes” when the transmitter signal becomes noisy, weak or fails. This control is factory-set at the 12 o'clock position to provide optimal operation in most applications.
- ❺ **Audio Output Level Control.** Lets you adjust output level to match the input level requirements of a mixer or amplifier. In most situations, this control should be set fully clockwise.
- ❻ **Power On Indicator.** This green light glows to indicate that the Power switch is on and power is applied to the receiver.
- ❼ **Power On/Off Button.** Turns the receiver on and off.
- ❽ **Antenna Connectors.** UHF-type connectors provide connection to the supplied 1/4-wave antennas or to coax cable used with remote antennas. They also provide connection to the optional Shure WA421 remote antenna cable kit used with optional WA380 telescoping and WA490 cable-type 1/2-wave antennas.
- ❾ **Output Connectors.** XLR connector provides balanced low-impedance mic level or line-level output. Quarter-inch phone jack provides unbalanced auxiliary level (high-impedance) output.
- ❿ **Mic/Line Slide Switch:** Controls output of balanced XLR connector. It can be set for microphone (–20 dBV maximum) or line-level (+0 dBV maximum).
- ⓫ **Power Jack:** Accepts power from the supplied ac adapter, or from any filtered 15 to 18 Vdc (400 mA minimum) supply. It will also accept the dc power cord from a Shure WA405 Antenna Power/Distribution System.

RECEIVER MOUNTING

SINGLE RACK-MOUNTED RECEIVER (FIGURE 6)

If the receiver is to be located on a table or other horizontal surface, attach the four adhesive bumpers to the bottom corners of the receiver. If the receiver is to be mounted in an audio equipment rack, identify the rack-mount kits supplied with your system and follow the appropriate assembly directions below.

1. Remove two screws from each side of the receiver.
2. Position the large mounting brackets over the holes on the sides of the receiver and secure them to the receiver with the screws removed in Step 1.
3. If you are not going to front mount the antennas with a Shure WA503 Front Mount Conversion Kit, insert the plastic plugs into the holes in the brackets.
4. Secure the assembly to a standard audio equipment rack with four screws.

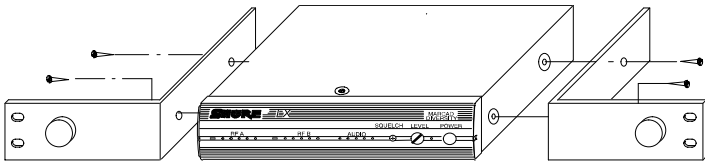

SINGLE RACK-MOUNTED RECEIVER

FIGURE 6

DOUBLE RACK-MOUNTED RECEIVERS

1. Remove the two screws on the outer side of each receiver.
2. Position the small mounting brackets over the holes on the outer side of each receiver, and secure them with the screws removed in Step 1.
3. Remove the screws on the inner side of each receiver.
4. Position two link bars over the holes and secure them with the screws removed in Step 3. For the receiver on the left, the link bar should be positioned so that its threaded hole is toward the front of the receiver. For the receiver on the right, the link bar should be positioned so that its threaded hole is toward the rear of the receiver.

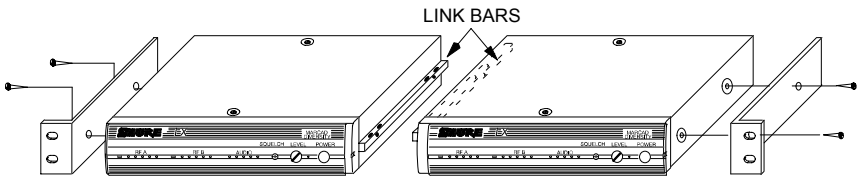

DOUBLE RACK-MOUNTED RECEIVERS

FIGURE 7

5. Place the two receivers next to each other so that the threaded holes in the link bars line up, one on top of the other.
6. Fasten the receivers together by inserting a small screw from the top into the threaded hole at the front of the link bar. Then insert the other screw from the bottom into the threaded hole at the rear of the link bar.
7. Secure the assembly to a standard audio equipment rack, using four screws.

RECEIVER CONNECTIONS

1. Attach the supplied quarter-wave antenna(s) to the antenna connector(s) on the receiver back panel. For best performance, the LX4 receiver antennas should be oriented with the tips pointing away from each other at a 45° angle from vertical. The LX3 receiver antenna should be vertical.
2. Connect the receiver output to the mixer or amplifier input, using a standard audio cable with a female 3-pin XLR connector or 1/4-inch phone plug.
3. Connect the ac adapter to the POWER jack on the rear panel of the receiver.
4. Plug the ac adapter into an appropriate ac power source.

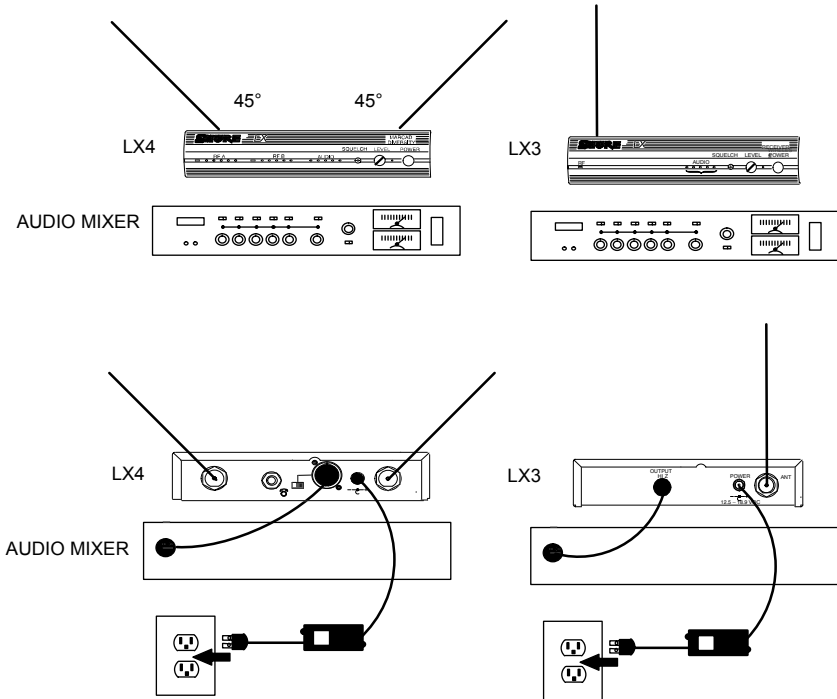

RECEIVER CONNECTIONS
FIGURE 8

NOTE: If the receiver is rack-mounted, the antenna(s) **must** extend above the rack cabinet or be remotely located.

Improved LX4 diversity performance may be obtained by installing one or both antenna(s) at a remote location and separating them by 1.5 meters (60 inches) or more. Shure WA380 telescoping or WA490 cable-type 1/2-wave antennas are recommended for remote location, and they should be connected to the receiver via WA421 Extension Cable Kit(s) or other suitable low-loss cable.

TRANSMITTER SETUP

LX1 BODY-PACK TRANSMITTER BATTERY INSTALLATION

1. With the transmitter POWER PWR/OFF switch in the OFF position, press down on the OPEN side of the battery compartment cover, slide it back and flip it open.
2. Insert a new 9V alkaline battery in the compartment. Observe proper battery polarity (“+/-”).

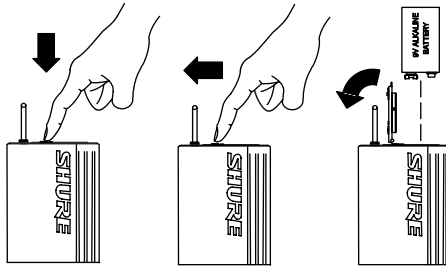

LX1 BODY-PACK TRANSMITTER BATTERY INSTALLATION
FIGURE 9

IMPORTANT: A fresh 9V alkaline battery should provide 18 to 20 hours of operation. However, an 8.4V nickel-cadmium (nicad) battery will only provide 3 hours of operation. Carbon-zinc and zinc-chloride batteries will not provide sufficient power, and are not recommended.

LX2 HAND-HELD MICROPHONE-TRANSMITTER BATTERY INSTALLATION

1. With the transmitter PWR/OFF switch in the OFF position, hold the upper part of the transmitter and unscrew the battery cover.
2. Install a fresh 9V alkaline battery. Make sure the battery terminals match the terminals in the transmitter.
3. Screw the battery cover back into place.

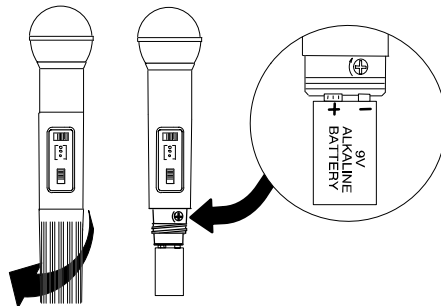

LX2 MICROPHONE-TRANSMITTER BATTERY INSTALLATION
FIGURE 10

CHECKING THE TRANSMITTER BATTERY

Turn the transmitter PWR/OFF switch to the PWR position and observe that one or two of the three lights on the transmitter glows. The amount of battery life remaining will be indicated by the color of the light(s), as shown in the following table.

Battery Life Indicators	Remaining Transmitter Operating Time*
Green	6 to 20 hours
Green and Amber	4 to 6 hours
Amber	2 to 4 hours
Red	1 hour or less

*Estimated operating time assumes the use of a fresh 9 V alkaline battery.

NOTE: A rechargeable 8.4V nicad battery causes the indicators to change more quickly than if using a 9V alkaline battery. Actual times depend on the type and brand of battery used.

CONNECTING A MICROPHONE OR INSTRUMENT CABLE TO THE LX1

1. Connect the microphone cable or instrument cable to the transmitter input jack.
2. Install the microphone by attaching it to the user's tie, shirt, or collar (lavalier mic), placing it over the user's head (headset mic), or affixing it to an acoustic musical instrument (instrument mic).
3. If using an instrument adapter cable, attach the other end of the instrument cable to the instrument output connector.

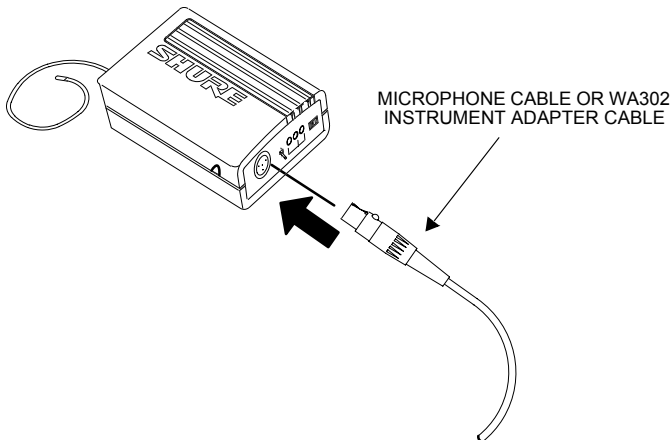

LX1 BODY-PACK TRANSMITTER CABLE CONNECTION
FIGURE 11

ATTACHING THE LX1 TO A BELT OR GUITAR STRAP

Attach the LX1 body-pack transmitter clip to a belt, waistband, or guitar strap by depressing the tab marked PRESS and slipping the belt or strap between the transmitter body and the belt clip, as shown in Figure 11. The clip holds tightest if the material is drawn to the clip's top wire (especially thinner guitar straps).

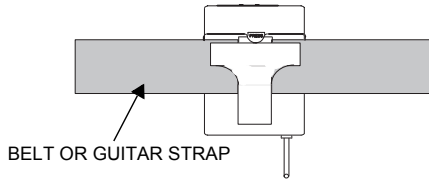

ATTACHING THE LX1 TO A BELT OR GUITAR STRAP
FIGURE 12

INSTALLING THE WA555 GRIP/SWITCH COVER ACCESSORY ON THE LX2

The LX2 transmitter comes with an external sleeve accessory (WA555) that prevents accidental movement of the microphone controls without affecting RF performance. It also provides the microphone with a “grip” feel. To install the grip/switch cover, proceed as follows:

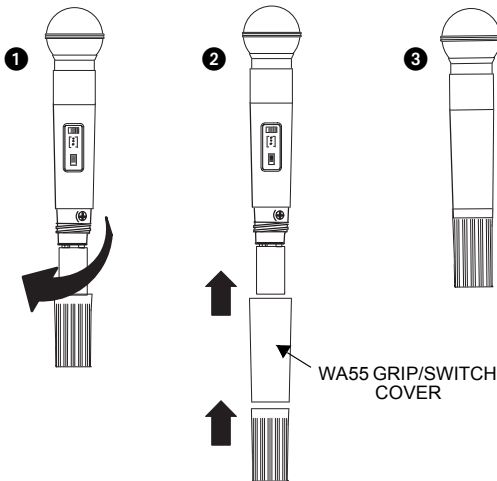

INSTALLING THE OPTIONAL LX2 GRIP/SWITCH COVER ACCESSORY
FIGURE 13

- 1 Unscrew the battery cover.
- 2 Slide the cover over the microphone handle, “lip” end downward. The cover fits snugly and requires additional pressure for the last inch of travel.
- 3 Reinstall the battery cover.

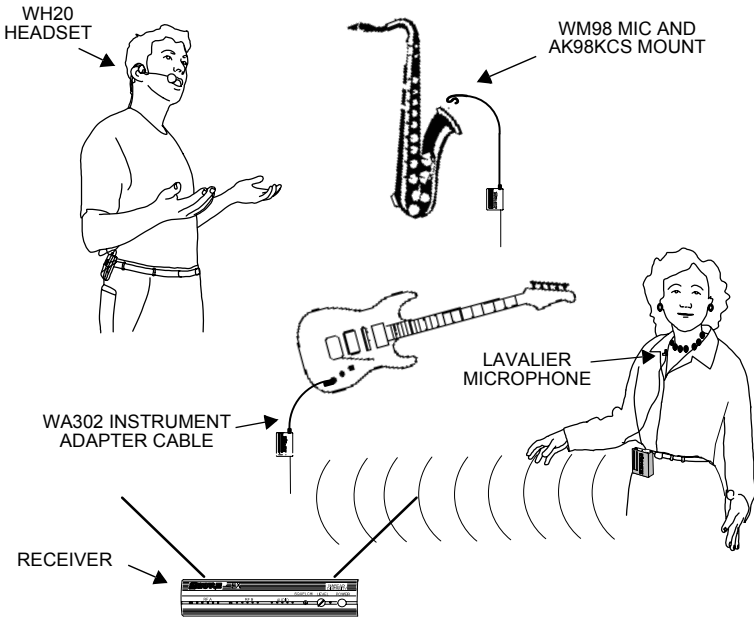

FIGURE 14

LX1 BODY-PACK SYSTEM SETUP AND OPERATION

OPERATING LX1 BODY-PACK SYSTEMS

1. Clip the LX1 body pack transmitter to your belt, waistband, or guitar strap.
2. Connect the lavalier microphone, headset or instrument adapter cable to the body-pack transmitter.
3. If you are using a lavalier microphone, clip the mic to your tie, lapel, or other garment. If you are using a headset, put the headset on. If you are using a Shure WM98 microphone, insert it into an A98KCS horn mount and clamp it to your horn. If you are using an instrument adapter cable, plug the cable into the instrument.
4. Slide the transmitter PWR/OFF switch to the PWR position. One of the three lights on the transmitter illuminates.
5. Press the POWER button on the receiver. The green "power on" light on the receiver and the RF light(s) illuminates.
6. Slide the transmitter ON/MUTE switch to the ON position and begin speaking or playing your instrument.

NOTE: If the red PEAK light on the receiver does not flicker during the loudest sounds, the transmitter gain may need to be increased. Refer to the *Adjusting the Transmitter Audio Gain Level* section. Then, if the system is still not operating properly, consult the Troubleshooting table.

7. During the performance or presentation, slide the ON/MUTE switch to the MUTE position when the system is not in use.
8. When the performance or presentation is over, slide the transmitter PWR/OFF switch to the OFF position to conserve battery power.

OPERATING THE LX2 HAND-HELD SYSTEM

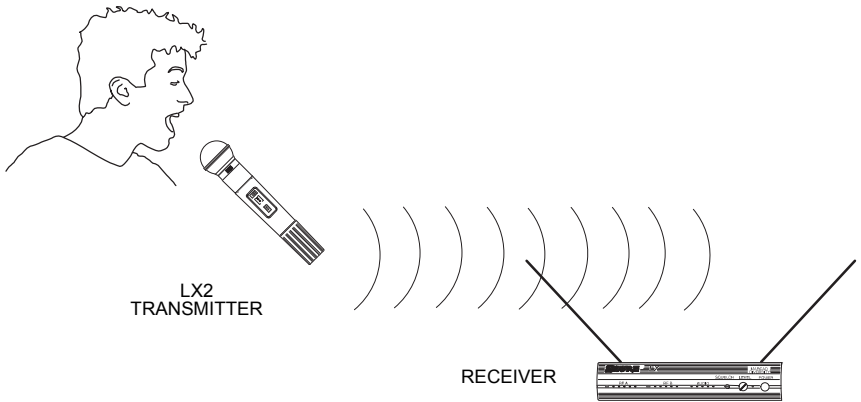

LX2 HAND-HELD MICROPHONE SYSTEM OPERATION

FIGURE 15

1. Slide the transmitter PWR/OFF switch to the PWR position. One of the three lights on the transmitter illuminates.
2. Press the POWER button on the receiver. The green power on indicator and the RF light(s) illuminates.
3. Slide the transmitter ON/MUTE switch to the ON position and begin speaking or playing your instrument.

NOTE: If the red PEAK light on the receiver does not flicker during the loudest sounds, the transmitter gain may need to be increased. Refer to the *Adjusting the Transmitter Audio Gain Level* section. Then, if the system is still not operating properly, consult the Troubleshooting table.

4. During the performance or presentation, slide the ON/MUTE switch to the MUTE position when the system is not in use.
5. When the performance or presentation is over, slide the transmitter PWR/OFF switch to the OFF position to conserve battery power.

GAIN AND SQUELCH ADJUSTMENT

ADJUSTING THE TRANSMITTER AUDIO GAIN LEVEL

The transmitter audio gain level has been factory pre-set to provide satisfactory output in most applications. However, for loud singers or high-output musical instruments, the preset level may be too high, as indicated by the constant glow of the red light on the receiver audio level meter. Soft-spoken talkers or singers may find that the factory setting is too low, as indicated by the failure of the amber audio level light to light at all.

To adjust the audio gain, locate the transmitter audio gain control and use the supplied screwdriver to adjust the control.

- For high sound pressure level applications, such as loud singing, decrease the audio gain level by rotating the gain control counterclockwise (while the vocalist is singing or the musical instrument is being played) until the red audio level light on the receiver flickers occasionally.
- For low sound pressure level applications, such as soft-spoken talkers, increase the audio gain level by rotating the gain control clockwise (while the vocalist is singing or the musical instrument is being played) until the red audio level light on the receiver flickers occasionally.

NOTE: If using the WH20TQG headset, you must increase the gain level to the full clockwise position. Then, if necessary, rotate the control back slightly.

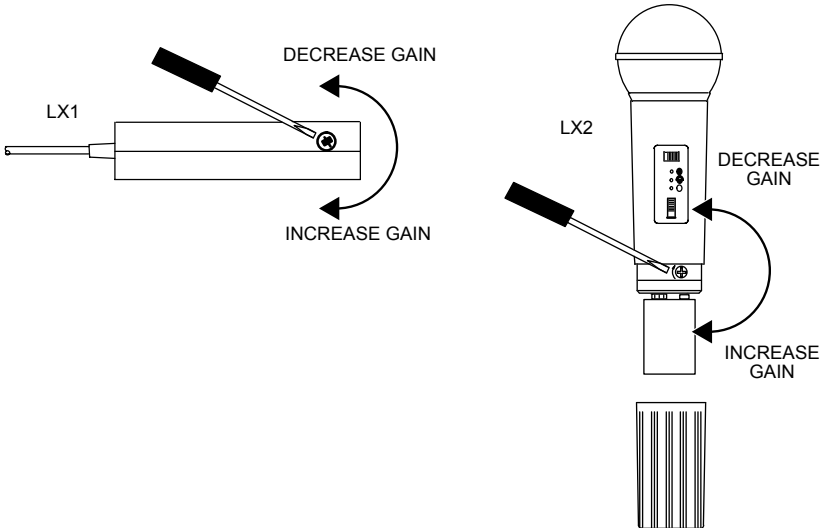

TRANSMITTER AUDIO GAIN LEVEL ADJUSTMENT
FIGURE 16

ADJUSTING THE RECEIVER SQUELCH CONTROL

The receiver squelch control is factory preset at the 12 o'clock position for optimum performance. No further adjustment is normally required. However, it is possible to adjust the squelch control to emphasize either signal quality or system range.

- To raise the squelch threshold, rotate the control clockwise. This causes the receiver to demand a higher quality signal (less noise before muting), but it *reduces* the operating range.
- To lower the squelch threshold, rotate the control counterclockwise. This allows a lower quality signal through (more noise before muting), but it *extends* the operating range.

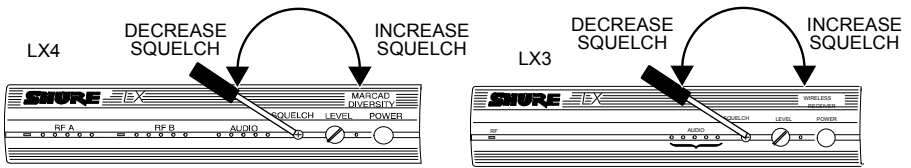

RECEIVER SQUELCH CONTROL ADJUSTMENT

FIGURE 17

TIPS FOR ACHIEVING OPTIMUM PERFORMANCE

- Maintain a line-of-sight between the transmitter and receiver antennas, if possible. Avoid placing transmitter and receiver where metal or other dense materials may be present.
- Avoid placing the receiver near computers or other RF generating equipment.
- Avoid placing the receiver in the bottom of an equipment rack unless the antennas are remotely located.
- Use the proper receiver antenna(s). A 1/4-wave antenna can be used if it is mounted directly on the receiver; use a 1/2-wave or other ground-plane-dependent antenna if antennas are remotely located. Use the Shure WA503 Front-Mount Antenna Conversion Kit to mount antennas on the front of the receiver.
- Mount 1/4-wave antennas with the antenna tips pointed away from each other at a 45° angle, and away from large metal objects.
- Use the proper antenna cable when remotely locating receiver antennas. For best performance, use the Shure WA421 50 W RG-58 coaxial antenna cable, and the minimum length necessary. For cable runs greater than 12.2 meters (40 feet), use RG-8 coaxial cable.
- Mount diversity antennas at least 1/4-wave apart [42 cm (17 inches) for VHF systems, although a 1.5 m (60 inches) spacing is preferred]. For multiple system installations, use the Shure WA405 Antenna/Power Distribution Kit or the WA470 Passive Antenna Splitter to minimize the number of antennas and reduce interference.
- Use the Shure WA302 Instrument Cable when using the LX1 transmitter with a musical instrument.
- If using multiple wireless systems, maintain a distance of at least 3 meters (10ft.) between the transmitter and the closest receiving antenna.

TROUBLESHOOTING

Problem	Solution
No sound; receiver RF light(s) and AUDIO lights not glowing.	<p>Make sure POWER switches on transmitter and receiver are on.</p> <p>Check transmitter Power/Battery Fuel Gauge to ensure that battery is providing power. Replace battery if necessary.</p> <p>Check receiver squelch setting.</p> <p>Check receiver antenna connection(s).</p> <p>Make sure at least one antenna is in the line of sight of the transmitter. If necessary, reduce the distance between transmitter and receiver.</p>
No receiver sound; RF and Audio Level meter lights glowing.	<p>Turn up the receiver audio output LEVEL control.</p> <p>Check for proper connection between receiver and microphone mixer.</p> <p>Talk into the microphone and observe the receiver audio level lights. If they glow, the problem is elsewhere in the sound system.</p>
Received signal is noisy or contains extraneous sounds with transmitter on.	<p>Check Power/Battery Fuel Gauge and replace battery if power is low.</p> <p>Remove local sources of RF interference, such as lighting equipment.</p> <p>If using a guitar or other instrument, make sure it is connected to the LX1 with a Shure WA302 adapter cable.</p> <p>Two transmitters may be operating on the same frequency. Locate and turn one off.</p> <p>Signal may be too weak. Reposition antennas. If possible, move them closer to the transmitter.</p> <p>Adjust receiver squelch control.</p>
Noise from receiver with transmitter off.	<p>Adjust receiver squelch control.</p> <p>Remove local sources of RF interference, such as lighting equipment.</p> <p>Reposition the receiver or antennas.</p>
Momentary loss of sound as transmitter is moved around performing area.	<p>Reposition receiver and perform another "walkthrough" test and observe the RF level or Diversity signal indicators. If audio dropouts persist, mark these "dead spots" in the performing area and avoid them during the performance.</p>

SPECIFICATIONS

RF Carrier Frequency Range

169.445 to 240.000 MHz (available frequencies depend on the applicable regulations in the country where the system is used)

Working Range

91 m (300 ft) under typical conditions. **NOTE:** Actual working range depends on RF signal absorption, reflection and interference.

Audio Frequency Response

50 to 15,000 Hz, +2 dB. **NOTE:** Overall system frequency response depends on the microphone element.

Audio Output Level (+15 kHz deviation, 1 kHz tone)

XLR connector (into 600 Ω load): 0 dBV (line), -20 dBV (mic)

1/4-inch connector (into 3 k Ω load): -8.8 dBV

Gain Adjustment Range

LX1: 40 dB

LX2: 25 dB

Impedances

LX1 (input): 1 M Ω

LX3 (output): 3 k Ω (1/4-inch phone jack)

LX4 (output): 150 Ω (XLR); 3 k Ω (1/4-inch phone jack)

Modulation

+15 kHz deviation compressor-expander system with pre- and de-emphasis

RF Power Output

LX1, LX2: 50 mW maximum (complies with FCC and IC regulations)

Dynamic Range

>102 dB, A-weighted

RF Sensitivity

0.45 μ V for 12 dB SINAD (typical)

Image Rejection

80 dB typical

Spurious Rejection

75 dB typical

Ultimate Quieting (ref. 15 kHz deviation)

>100 dB, A-weighted

Audio Polarity

Positive pressure on microphone diaphragm (or positive voltage applied to tip of WA302 phone plug) produces positive voltage on pin 2 with respect to pin 3 of low impedance output and the tip of the high impedance 1/4-inch output.

System Distortion (ref. +15 kHz deviation, 1 kHz modulation)

0.3% THD typical

Power Requirements

LX1, LX2: 9V alkaline battery; 8.4V Nicad optional

LX3, LX4: 12.5–18 Vdc (negative ground), 400 mA

Battery Life

18 to 20 hours

Operating Temperature Range

-20° to 50° C (-45 to 122° F). **NOTE:** Battery characteristics may limit this range.

Overall Dimensions

LX1: 83 mm H x 64 mm W x 26 mm D ($3\frac{1}{4}$ x $2\frac{1}{2}$ x $1\frac{1}{32}$ in.)

LX2/58, LX2/BETA 58: 241 mm L x 51 mm Dia. ($9\frac{1}{2}$ x 2 in.)

LX2/87, LX2/BETA 87: 216 mm L x 51 mm Dia. ($8\frac{1}{2}$ x 2 in.)

LX3, LX4: 43 mm H x 214 mm W x 183 mm D ($1\frac{11}{16}$ x $8\frac{7}{16}$ x $7\frac{3}{16}$ in.)

Net Weight

LX1: 79 g (2.8 oz.) without battery

LX2/58, LX2/BETA 58: 295 g (10.4 oz.) without battery

LX2/87, LX2/BETA 87: 193 g (6.8 oz.) without battery

LX3: 1,049 g (2 lbs, 5 oz.)

LX4: 1,105 g (2 lbs, 7 oz.)

CERTIFICATION

LX1, LX2 Transmitters: Type Accepted under FCC Parts 74 and 90. Certified by IC in Canada under TRC-78.

LX3, LX4 Receivers: Approved under the Notification provision of FCC Part 15. Certified by IC in Canada under TRC-78.

LX1, LX2, LX3, LX4: RA Type Approved to MPT 1345, MPT 1350, ETS 300 422. BZT Type Approved to FTZ 17TR 2019, BAPT 122 R1.

Meets Requirements of EMC Standard EN 301 489 Parts 1 and 9. Meets Low Voltage Directive. LX Systems are eligible to carry the CE marking.

Shure Models LX1 and LX2 Transmitters meet the essential requirements of the European R&TTE Directive 99/5/EC and are eligible to carry the CE marking.

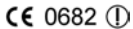

Shure Models LX3 and LX4 Receivers meet the essential requirements of the European R&TTE Directive 99/5/EC and are eligible to carry the CE marking.

Power supply meets the following safety standard:

PS40 Power Supply: UL 1310, CAN/CSA 22.2 No. 223.

PS40E Power Supply: EN 60950

PS40UK Power Supply: EN 60950

FURNISHED ACCESSORIES

Microphone Stand Adapter (LX2)	WA370A
Single Receiver HR Rack Panel Kit	WA500
Dual Receiver (Side-by-Side) HR Rack Panel Kit (LX4)	WA502
Grip/Switch Cover (LX2)	WA555
Zipper Bag (LX1)	26A13
Zipper Bag (LX2)	26A13
Screwdriver	80A498

OPTIONAL ACCESSORIES

Instrument Adapter Cable, 1/4" Plug (LX1)	WA302
Instrument Adapter Cable, Right-Angle 1/4" Plug (LX1)	WA304
Microphone Adapter Cable (LX1)	WA310
4-Pin Female Mini-Connector TA4F (LX1)	WA330
In-Line Audio Switch (LX1)	WA360
1/2-Wave Telescoping Antenna (169 - 185 MHz)	WA380A*
1/2-Wave Telescoping Antenna (185 - 200 MHz)	WA380B*
1/2-Wave Telescoping Antenna (200 - 230 MHz)	WA380C*
Antenna/Power Distribution System, 120 Vac.	WA405

Antenna/Power Distribution System, 230 Vac	WA405E
1.8 Meter (6 ft.) Receiver-Mixer Cable (1/4" phone to XLR)	WA410
6.1 Meter (20 ft.) Antenna Extension Cable	WA421
Antenna Rack Mount Kit	WA440
Passive Antenna Splitter	WA470
1/2-Wave Cable Antenna (169 - 185 MHz)	WA490A
1/2-Wave Cable Antenna (185 - 200 MHz)	WA490B
1/2-Wave Cable Antenna (200 - 216 MHz)	WA490C
Single Receiver Front-Mount Antenna Conversion Kit	WA503
Pelican Protector® Carrying Case for Single LX or SC Wireless System	WA525
Nylon Carrying Case	WA590

*Includes wall-mount bracket.

REPLACEMENT PARTS

Universal Horn Clamp (for WM98)	A98KCS
AC Adapter (120 Vac, 60 Hz)	PS40
AC Adapter (230 Vac, 50/60 Hz, Europlug)	PS40E
AC Adapter (230 Vac, 50/60 Hz, UK)	PS40UK
SM58® Cartridge with Grille (LX2/58)	R158
BETA 58® Cartridge with Grille (LX2/BETA 58)	R178
SM87 Cartridge with Grille (LX2/87)	R165
BETA 87A Cartridge with Grille (LX2/BETA 87)	R166
BETA 87C Cartridge with Grille (LX2/BETA 87)	RPW100
Matte Silver Grille (LX2/58)	RK143G
Matte Silver Grille (LX2/BETA 58)	RK265G
Matte Silver Grille (LX2/BETA 87)	RK313
Black Grille (LX2/87)	RK214G
Black Grille (LX2/BETA 58)	RK323G
Black Grille (LX2/BETA 87)	RK324G
Belt Clip (LX1)	53A8247A
1/4-Wave Antenna (169 - 186 MHz)	90A8380
1/4-Wave Antenna (186 - 204 MHz)	90B8380
1/4-Wave Antenna (204 - 216 MHz)	90C8380
1/4-Wave Antenna (216 - 240 MHz)	90D8380

THIS RADIO EQUIPMENT IS INTENDED FOR USE IN MUSICAL PROFESSIONAL ENTERTAINMENT AND SIMILAR APPLICATIONS.

NOTE: THIS RADIO APPARATUS MAY BE CAPABLE OF OPERATING ON SOME FREQUENCIES NOT AUTHORIZED IN YOUR REGION. PLEASE CONTACT YOUR NATIONAL AUTHORITY TO OBTAIN INFORMATION ON AUTHORIZED FREQUENCIES FOR WIRELESS MICROPHONE PRODUCTS IN YOUR REGION.

Licensing: A ministerial license to operate this equipment may be required in certain areas. Consult your national authority for possible requirements.

Shure Transmitters Models LX1 and LX2 may be used in the countries and frequency ranges listed on page 22.

LICENSING INFORMATION

Changes or modifications not expressly approved by Shure Incorporated could void your authority to operate the equipment. Licensing of Shure wireless microphone equipment is the user's responsibility, and licensability depends on the user's classification and application, and on the selected frequency. Shure strongly urges the user to contact the appropriate telecommunications authority concerning proper licensing, and before choosing and ordering frequencies other than standard frequencies.

Country Code	LX1, LX2 (169 - 250 MHZ)
A	230 - 250 MHZ *
B	174 - 223 MHZ *
CH	174 - 223 MHZ *
D	174 - 223 MHZ *
E	174 - 223 MHZ *
F	174 - 223 MHZ *
GB	174 - 223 MHZ *
GR	*
I	174 - 223 MHZ *
IRL	*
L	*
NL	174 - 223 MHZ *
P	174 - 223 MHZ *
DK	*
FIN	174 - 223 MHZ *
N	174 - 223 MHZ *
All Other Countries	*

*Please contact your national authority for information on available legal frequencies for your area and legal use of the equipment.

FULL TWO YEAR WARRANTY

Shure warrants this product to be free in normal use of any defects in workmanship and materials for two (2) years from the date of purchase. If your Shure product fails within this period, call 1-800-516-2525 in the United States for details on repair, replacement, or refund. In Europe, contact Shure Incorporated Europe GmbH at +49 (7131) 7214-0 or +49 (7131) 7214-30 (service hotline) or contact your authorized Shure distributor. This warranty does not cover abuse or misuse of the product, use contrary to Shure's instruction, ordinary wear and tear, an act of God or unauthorized repair.

GARANTIE TOTALE DE DEUX ANS

Shure garantit que, pour un usage normal, ce produit sera exempt de tout défaut de fabrication et de matériaux pour une période de deux (2) ans à compter de la date d'achat. Si ce produit Shure tombe en panne pendant cette période, appeler le 1-800-516-2525 aux États-Unis pour obtenir des renseignements sur les réparations, les remplacements ou les remboursements. En Europe, appeler Shure Incorporated Europe GmbH au +49 (7131) 7214-0 ou +49 (7131) 7214-30 (téléphone rouge du service d'entretien) ou contacter le centre de réparations Shure agréé. Cette garantie n'est pas applicable en cas d'utilisation abusive ou incorrecte du produit, d'utilisation contraire aux instructions de Shure, d'usure normale, de catastrophe naturelle ou de réparation non autorisée.

UNBESCHRÄNKTE ZWEIJÄHRIGE GEWÄHRLEISTUNG

Shure garantiert, dass dieses Produkt bei normalem Gebrauch für einen Zeitraum von zwei (2) Jahren ab dem Kaufdatum keine Material- oder Verarbeitungsfehler aufweist. Falls Ihr Shure Produkt innerhalb dieses Zeitraums ausfällt, ist die Kundendienstabteilung in den USA unter der Nummer 1-800-516-2525 zu verständigen, um Informationen über Reparatur, Umtausch oder Rückerstattung zu erhalten. Kunden in Europa wenden sich bitte an Shure Incorporated Europe GmbH unter der Nummer +49 (7131) 7214-0 bzw. +49 (7131) 7214-30 (Service-Hotline) oder an den zuständigen Shure-Vertragshändler. Diese Garantie gilt nicht bei unsachgemäßer Verwendung oder Zweckentfremdung des Produkts, Einsatz entgegen der Anweisungen von Shure, normalem Verschleiß, Schäden durch höhere Gewalt oder nicht berechtigter Reparatur.

GARANTÍA COMPLETA DE DOS AÑOS

Shure garantiza que si este producto se usa de modo normal, estará libre de defectos por un período de dos (2) años a partir de la fecha de compra. Si el producto Shure muestra defectos durante este período, llame al 1-800-516-2525 (en los EE.UU.) para obtener información acerca de la reparación o reemplazo del mismo, o de la devolución de su dinero. En Europa, llame a Shure Incorporated Europe GmbH al teléfono +49 (7131) 7214-0 ó +49 (7131) 7214-30 (línea de servicio) o comuníquese con el distribuidor autorizado de productos Shure. Esta garantía no cubre el abuso o uso indebido del producto, uso contrario a las instrucciones dadas por Shure, desgaste normal, actos de fuerza mayor o reparaciones por entidades no autorizadas para ello.

GARANZIA COMPLETA DI DUE ANNI

Shure garantisce che, in condizioni di uso regolare, questo prodotto sarà esente da difetti di materiale e manodopera per due anni a decorrere dalla data dell'acquisto. In caso di guasto del prodotto Shure durante questo periodo, chiamate il numero 1-800-516-2525 (negli USA) per informazioni sulla riparazione, sulla sostituzione o sul rimborso. In Europa, rivolgetevi alla Shure Incorporated Europe GmbH, al numero +49 (7131) 7214-0 o al numero +49 (7131) 7214-30 (linea di assistenza) oppure rivolgetevi al rivenditore autorizzato Shure. Questa garanzia non si applica in caso di abuso o uso improprio del prodotto, uso contrario alle istruzioni Shure, usura ordinaria, danni di forza maggiore o riparazioni non autorizzate.

EU DECLARATION OF CONFORMITY

We,
of

Shure Incorporated
222 Hartrey Avenue
Evanston, IL 60202-3696, U.S.A

Declare under our sole responsibility that the following products

Model:	<u>LX1</u>	Description:	<u>Transmitter, Body Pack</u>
Model:	<u>LX2</u>	Description:	<u>Transmitter, Handheld</u>
Model:	<u>LX3</u>		<u>Receiver</u>
Model:	<u>LX4</u>		<u>Receiver</u>
Model:	<u>PS40E, PS40UK</u>	Description:	<u>AC/DC Power Adapter</u>

Conforms to the essential requirements and other relevant provisions of the R&TTE Directive (1999/5/EC).

The products comply with the following product family, harmonized or national standards:

LX1, LX2, LX3, and LX4;

EN 300 422-1

EN 300 422-2

EN 301 489-1

EN 301 489-9

PS40E, PS40UK: EN 60950

Manufacturer: Shure Incorporated

Signed



Date JULY 12, 2002

Name, Title Craig Kozokar

Project Engineer, Corporate Quality, Shure Incorporated

European Contact: Shure Europe GmbH

Wannenäcker Str. 28, 74078 Heilbronn, Germany

Phone: 49-7131-7214-0, Fax: 49-7131-7214-14

Trademark Notices: The stylized Shure logo, and the word “Shure” are registered trademarks of Shure Incorporated in the United States. “Pelican” is a registered trademark of Pelican Products, Inc.

The SHURE logo is rendered in a bold, blue, sans-serif font. The letters are thick and closely spaced, with a slight shadow effect that gives the logo a three-dimensional appearance. The word "SHURE" is followed by a registered trademark symbol (®).

SHURE Incorporated Web Address: <http://www.shure.com>

5800 W. Touhy Avenue, Niles, IL 60714-4608, U.S.A.

In U.S.A., Phone: 1-847-600-2000 Fax: 1-847-600-1212

In Europe, Phone: 49-7131-72140 Fax: 49-7131-721414

In Asia, Phone: 1-852-2893-4290 Fax: 1-852-2893-4055

International Fax: 1-847-600-6446