

ET30000-5
ET25000-5
ET20000-5
ET15000-5
ET10000-5
ET5000
ET3500
ET2500

(list of variations available in the manual)

SOLID STATE FM TRANSMITTER

Rev. 00- 17/11/2013
Cod. MAN1029UUK

ELENOS
World Broadcast Experience

USER MANUAL



Via G. Amendola 9, 44028 Poggio Renatico Ferrara (Italy)
C.C.I.A.A. 101 216, Tax code and VAT reg. no. IT00415540384



UNI EN ISO 9001:2008 certified company
Certificate No.102222A

Please remember to register the product purchased on <http://www.elenos.com/product-registration/>

Please contact technical support service for information and assistance:

Elenos

Ph : +39 0532 829965
Fax : +39 0532 829177
E-mail : info@elenos.com
Internet web site : www.elenos.com

Elenos USA

1315 nw 98th Ct. Suite 9, 33172 Miami (Florida), Ph 1-855-ELENOS-0 (1-855-353-6670)

Elenos APAC

53/64 Saracha Villa, Sansuk Muang Chonburi (Thailand), Ph +66 83 618-9333

Please complete the RMA form (ITA <http://www.elenos.com/it/elenos-rma/> or ENG <http://www.elenos.com/elenos-rma/>) and provide the equipment serial number (indicated on the nameplate).

Elenos s.r.l. declares that the equipment described in this document is compliant with the 1999/05/EC Directive.



For details please refer to the "EC Marking" section.

EC Declaration of Conformity

According to Directive 1999/5/EC (R&TTE)



We : **ELENOS s.r.l. - via G.Amendola, 9 – 44028 Poggio Renatico (FE) - Italy**

Declare under our sole responsibility that the product:

ET3000-5, ET27000/30-5, ET25000/30-5, ET20000/30-5, ET18000/30-5, ET15000/30-5, ET12000/30-5, ET10000/30-5, ET8000/30-5, ET7000/30-5, ET5000/30-5, ET4000/30-5, ET3500/30-5, ET3000/30-5
ET25000-5, ET20000/25-5, ET18000/25-5, ET15000/25-5, ET12000/25-5, ET10000/25-5, ET8000/25-5, ET7000/25-5, ET5000/25-5, ET4000/25-5, ET3500/25-5, ET3000/25-5, ET2500/25-5
ET20000-5, ET18000/20-5, ET15000/20-5, ET12000/20-5, ET10000/20-5, ET8000/20-5, ET7000/20-5, ET5000/20-5, ET4000/20-5, ET3500/20-5, ET3000/20-5, ET2500/20-5, ET2000/20-5
ET15000-5, ET12000/15-5, ET10000/15-5, ET8000/15-5, ET7000/15-5, ET5000/15-5, ET4000/15-5, ET3500/15-5, ET3000/15-5, ET2500/15-5, ET2000/15-5
ET10000-5, ET8000/10-5, ET7000/10-5, ET5000/10-5, ET4000/10-5, ET3500/10-5, ET3000/10-5, ET2500/10-5, ET2000/10-5
ET5000, ET4000/5, ET3500/5, ET3000/5, ET2500/5, ET2000/5, ET1800/5, ET1500/5, ET1200/5, ET1000/5, ET800/5, ET500/5
ET3500, ET3000/3.5, ET2500/3.5, ET2000/3.5, ET1800/3.5, ET1500/3.5, ET1200/3.5, ET1000/3.5, ET800/3.5, ET500/3.5
ET2500, ET2000/2.5, ET1800/2.5, ET1500/2.5, ET1200/2.5, ET1000/2.5, ET800/2.5, ET500/2.5
E30000-5, E27000/30-5, E25000/30-5, E20000/30-5, E18000/30-5, E15000/30-5, E12000/30-5, E10000/30-5, E8000/30-5, E7000/30-5, E5000/30-5, E4000/30-5, E3500/30-5, E3000/30-5
E25000-5, E20000/25-5, E18000/25-5, E15000/25-5, E12000/25-5, E10000/25-5, E8000/25-5, E7000/25-5, E5000/25-5, E4000/25-5, E3500/25-5, E3000/25-5, E2500/25-5
E20000-5, E18000/20-5, E15000/20-5, E12000/20-5, E10000/20-5, E8000/20-5, E7000/20-5, E5000/20-5, E4000/20-5, E3500/20-5, E3000/20-5, E2500/20-5, E2000/20-5
E15000-5, E12000/15-5, E10000/15-5, E8000/15-5, E7000/15-5, E5000/15-5, E4000/15-5, E3500/15-5, E3000/15-5, E2500/15-5, E2000/15-5
E10000-5, E8000/10-5, E7000/10-5, E5000/10-5, E4000/10-5, E3500/10-5, E3000/10-5, E2500/10-5, E2000/10-5

With intended purpose: VHF FM broadcast transmitters and amplifiers

And manufactured by: ELENOS s.r.l.

To which this declaration relates is in conformity with the essential requirements and other relevant requirements of the R&TTE Directive (1999/5/CE).

The product is in conformity with the following standards and/or other normative documents:

Health and safety requirements pursuant to Article 3.1.a

Standards applied: EN60215:1989+A1:1992+A2:1994

Protection requirements concerning electromagnetic compatibility pursuant to Article 3.1.b

Standards applied: EN 301 489-1 V1.6.1 ; EN 301 489-11 V1.3.1

Measures for the efficient use of the radio frequency spectrum pursuant to Article 3.2

Standards applied: EN 302 018-2 V1.2.1

Supplementary information :

Notified body involved: IMQ S.p.a.

Technical file held by : Elenos s.r.l

Place and Date: Ferrara September 05, 2013

Responsible person : Leonardo Busi (Amministratore unico)

Tel. +39 0532 829965

e-mail: leonardobusi@elenos.com

Signature:

Series models

Transmitter	Amplifier	Middle amplifier stage	Combiner way number	Maximum output power	Driver
ET30000-5	E30000-5	E5000	6	30KW	ETG20
ET27000/30-5 ET25000/30-5 ET20000/30-5 ET18000/30-5 ET15000/30-5 ET12000/30-5 ET10000/30-5 ET8000/30-5 ET7000/30-5 ET5000/30-5 ET4000/30-5 ET3500/30-5 ET3000/30-5	E27000/30-5 E25000/30-5 E20000/30-5 E18000/30-5 E15000/30-5 E12000/30-5 E10000/30-5 E8000/30-5 E7000/30-5 E5000/30-5 E4000/30-5 E3500/30-5 E3000/30-5	E5000 E5000 E3500/5 E3000/5 E2500/5 E2000/5 E1800/5 E1500/5 E1200/5 E1000/5 E800/5 E800/5 E500/5	6	Equal to the rated value	ETG20
ET25000-5	E25000-5	E5000	5	25KW	ETG20
ET20000/25-5 ET18000/25-5 ET15000/25-5 ET12000/25-5 ET10000/25-5 ET8000/25-5 ET7000/25-5 ET5000/25-5 ET4000/25-5 ET3500/25-5 ET3000/25-5 ET2500/25-5	E20000/25-5 E18000/25-5 E15000/25-5 E12000/25-5 E10000/25-5 E8000/25-5 E7000/25-5 E5000/25-5 E4000/25-5 E3500/25-5 E3000/25-5 E2500/25-5	E4000/5 E4000/5 E3000/5 E2500/5 E2000/5 E1800/5 E1500/5 E1000/5 E800/5 E800/5 E800/5 E500/5	5	Equal to the rated value	ETG20
ET20000-5	E20000-5	E5000	4	20KW	ETG20
ET18000/20-5 ET15000/20-5 ET12000/20-5 ET10000/20-5 ET8000/20-5 ET7000/20-5 ET5000/20-5 ET4000/20-5 ET3500/20-5 ET3000/20-5 ET2500/20-5 ET2000/20-5	E18000/20-5 E15000/20-5 E12000/20-5 E10000/20-5 E8000/20-5 E7000/20-5 E5000/20-5 E4000/20-5 E3500/20-5 E3000/20-5 E2500/20-5 E2000/20-5	E5000 E4000/5 E3000/5 E2500/5 E2000/5 E1800/5 E1500/5 E1000/5 E1000/5 E800/5 E800/5 E500/5	4	Equal to the rated value	ETG20

ET15000-5	E15000-5	E5000	3	15KW	ETG20
ET12000/15-5	E12000/15-5	E4000/5	3	Equal to the rated value	ETG20
ET10000/15-5	E10000/15-5	E3500/5			
ET8000/15-5	E8000/15-5	E3000/5			
ET7000/15-5	E7000/15-5	E2500/5			
ET5000/15-5	E5000/15-5	E1800/5			
ET4000/15-5	E4000/15-5	E1500/5			
ET3500/15-5	E3500/15-5	E1200/5			
ET3000/15-5	E3000/15-5	E1000/5			
ET2500/15-5	E2500/15-5	E1000/5			
ET2000/15-5	E2000/15-5	E800/5			
ET10000-5	E10000-5	E5000	2	10KW	ETG20
ET8000/10-5	E8000/10-5	E4000/5	2	Equal to the rated value	ETG20
ET7000/10-5	E7000/10-5	E3500/5			
ET5000/10-5	E5000/10-5	E2500/5			
ET4000/10-5	E4000/10-5	E2000/5			
ET3500/10-5	E3500/10-5	E1800/5			
ET3000/10-5	E3000/10-5	E1500/5			
ET2500/10-5	E2500/10-5	E1500/5			
ET2000/10-5	E2000/10-5	E1000/5			

ET5000	E5000	E5000	-	5KW	ETG20
ET4000/5	E4000/5	E4000/5		Equal to the rated value	ETG20
ET3500/5	E3500/5	E3500/5			
ET3000/5	E3000/5	E3000/5			
ET2500/5	E2500/5	E2500/5			
ET2000/5	E2000/5	E2000/5			
ET1800/5	E1800/5	E1800/5	-		
ET1500/5	E1500/5	E1500/5			
ET1200/5	E1200/5	E1200/5			
ET1000/5	E1000/5	E1000/5			
ET800/5	E800/5	E800/5			
ET500/5	E500/5	E500/5			
ET3500	E3500	E3500	-	3.5KW	ETG20
ET3000/3.5	E3000/3.5	E3000/3.5		Equal to the rated value	ETG20
ET2500/3.5	E2500/3.5	E2500/3.5			
ET2000/3.5	E2000/3.5	E2000/3.5			
ET1800/3.5	E1800/3.5	E1800/3.5			
ET1500/3.5	E1500/3.5	E1500/3.5	-		
ET1200/3.5	E1200/3.5	E1200/3.5			
ET1000/3.5	E1000/3.5	E1000/3.5			
ET800/3.5	E800/3.5	E800/3.5			
ET500/3.5	E500/3.5	E500/3.5			
ET2500	E2500	E2500	-	2.5KW	ETG20
ET2000/2.5	E2000/2.5	E2000/2.5		Equal to the rated value	ETG20
ET1800/2.5	E1800/2.5	E1800/2.5			
ET1500/2.5	E1500/2.5	E1500/2.5			
ET1200/2.5	E1200/2.5	E1200/2.5	-		
ET1000/2.5	E1000/2.5	E1000/2.5			
ET800/2.5	E800/2.5	E800/2.5			
ET500/2.5	E500/2.5	E500/2.5			

Contents

1 General information	13
1.1 Intended use	13
1.2 Transport	13
1.3 Unpacking	13
1.4 Storage	13
1.5 Decommissioning and disposal	14
1.6 Checking the product purchased	14
2 Product description	15
2.1 Combiner/Splitter unit	15
2.2 Control unit (ET30000-5, ET25000-5, ET20000-5)	17
2.2.1 External connectors pin-out	19
2.2.1.1 Interface connector	19
2.2.1.2 Profiles connector	19
2.2.1.3 TC/TS connector	20
2.2.1.4 Full scale values	21
2.2.1.5 Master connector	22
2.2.1.6 EIA485 connector	22
2.2.1.7 Aux1 connector	23
2.2.1.8 Dummy Load connector	23
2.3 Control unit (ET15000-5, ET10000-5)	24
2.4 Dummy load	27
2.4.1 External connectors pin-out	28
2.4.1.1 Dummy Load connector	28
2.5 Amplifiers	29
2.5.1 External connectors pin-out	31
2.5.1.1 EIA485/TELEMETRY connector	31
2.5.1.2 TC/TS connector	32
2.5.1.3 PROFILES connector	33
2.5.1.4 TCP/IP, RESERVED connector	34
2.5.1.5 EIA485 connector	34
2.6 Exciters	35
2.7 System connections	35
2.8 Technical datasheet	36
2.9 Protections	52
2.9.1 Software protections	52
2.9.1.1 IPF (Intelligent Proportional Foldback)	52
2.9.1.2 IPC (Intelligent Power Control)	52
2.9.1.3 Safety Management (“Lifextender” option) ®	52
2.9.2 Hardware protections	54
2.10 Options	55
3 Use instructions	57
3.1 User interface	57
3.1.1 Control unit user interface	57
3.1.1.1 Power setting	59
3.1.1.2 Frequency setting	59

3.1.1.3 Input password.....	59
3.1.1.4 Profile.....	59
3.1.1.5 Main alarm.....	59
3.1.1.6 Temperatures.....	60
3.1.1.7 Main view.....	60
3.1.1.8 Events list.....	60
3.1.1.9 Events history.....	60
3.1.1.10 Dual drive.....	61
3.1.1.11 Dual drive drive.....	61
3.1.1.12 Dual drive handler.....	61
3.1.1.13 Temperatures DL.....	61
3.1.1.14 485 speed set.....	62
3.1.1.15 Voltages.....	62
3.1.1.16 System info.....	62
3.1.1.17 System time.....	62
3.1.1.18 Clock pwr target.....	63
3.1.1.19 Com. ID LC/RT disp. mode.....	63
3.1.1.20 Temperature unit.....	63
3.1.1.21 Max reflected power.....	64
3.1.1.22 SWR foldback setting.....	64
3.1.1.23 No mains alarm setting.....	64
3.1.1.24 Password setting.....	65
3.1.1.25 Password recovery.....	65
3.1.1.26 UPS settings.....	65
3.1.1.27 Uart 0,1,2 info.....	66
3.1.1.28 GSM field strength.....	67
3.1.1.29 -3dB alarm setting.....	67
3.1.1.30 String ID/Pager ID.....	67
3.1.1.31 Phone N.1 .. 5.....	67
3.1.2 Amplifier user interface.....	68
3.1.2.1 TX control panel.....	69
3.1.2.2 View TX parameters 1.....	69
3.1.2.3 View TX parameters 2.....	69
3.1.2.4 Alarms list.....	70
3.1.2.5 Events history.....	70
3.1.2.6 Password.....	70
3.1.2.7 Password setting.....	70
3.1.2.8 Password recovery.....	71
3.1.2.9 System config.....	71
3.1.2.10 System config 1.....	72
3.1.2.11 Communication port set.....	72
3.1.2.12 System info.....	72
3.1.2.13 System time.....	73
3.1.2.14 Clock power target.....	73
3.1.2.15 Enable alarms SMS.....	74
3.1.2.16 Display alarms bit.....	74
3.1.2.17 User alarms data.....	75
3.1.2.18 User alarms timers.....	75
3.1.2.19 Lifextender.....	76
3.1.2.20 GSM and modem service.....	76
3.1.2.21 Phone N.1 to 4 / N.5 to 8.....	77
3.1.2.22 Uart 0,1 info.....	77
3.1.2.23 SMS Diagnostic.....	77

3.1.3 Exciter user interface	78
3.2 Alarms/events list	79
3.2.1 Control unit alarms/events list	79
3.2.2 Amplifier alarms/events list	80
3.2.3 Exciter alarms/events list	83
3.3 SMS list.....	84
3.3.1 SMS commands (submit)	84
3.3.2 Status/alarm SMS (reception)	84
3.4 Externally connectable optional equipment	86
3.4.1 Connection to PC	86
3.4.1.1 Control unit hyperterminal interface	87
3.4.1.2 Amplifier hyperterminal interface.....	95
3.4.1.3 Exciter hyperterminal interface	102
3.4.2 Connection to telemetry	103
3.4.3 Connection to exchange unit and/or audio matrix	104
3.4.4 Connection to Elenos E.BOX module	107
4 Maintenance	109
4.1 Device overview	109
4.1.1 ET30000-5.....	110
4.1.2 6-way combiner	111
4.1.3 Control unit.....	113
4.1.4 ETG20 exciter	116
4.1.5 E5000 amplifier	118
4.1.6 6-way dummy load	121
4.2 Settings	123
4.2.1 System addresses.....	123
4.2.2 Power supply Dip-switch in E5000 amplifier.....	124
4.3 Spare parts and mounting.....	126
4.4 Routine maintenance (cleaning, replacements, checks).....	126
4.5 Operating faults (symptoms, causes and remedies)	127

1 General information

1.1 Intended use

The equipment referred to in this manual is solid state transmitters with adjustable output power from 0W to a maximum rated value (see Section “Series models”), to be used in the whole FM band between 87.5 and 108 MHz, in 10 kHz steps.

The design of such equipment is based on SCALABILITY: it envisages the reuse on different scale levels of resources used on a basic model (the E5000 amplifier), so as to obtain higher transmission powers.

The same technology, same user interfaces and same components within each module mean **more economical spare part and repair management, more economical operator training and experience which can be easily shared with others.**

The available options are as follows: STEREO, AES/EBU (both with integrated MPX), according to the relative modulator version.

The distinctive characteristics of Elenos products remain constant: ECOSAVING, ICEFET, VSWR PEAK HOLD, monitoring possibility, protection against corrosion, etc..

The LIFEXTENDER functionality can be added.

1.2 Transport

The equipment must only be transported in its original packaging. However, although it has been designed to prevent the machine being damaged, even in the event of incorrect manoeuvres, it is recommended to respect the “HIGH/LOW” direction and not to subject it to impact.

Ensure that the transport and lifting equipment are suitable for supporting the load.

1.3 Unpacking

The personnel in charge of handling the load must use protective gloves and accident-prevention footwear.

Before lifting or moving the equipment or any of its parts, check that the operating area has been cleared, also considering a safe area in order to prevent damage to people and/or properties that could be within the manoeuvring radius.

1.4 Storage

Should it be necessary to store the equipment for any reason, it is necessary that:

- in the storage area, the temperature is between -20° and +55°C, with humidity of no more than 90% at 55°C;
- the equipment is disconnected from energy sources;
- the equipment is clean and there are no dust deposits;
- the equipment is covered with a waterproof sheet.

1.5 Decommissioning and disposal

For all the aspects regarding the disposal of the product, please refer to the specific European Directives.

Please note that **the equipment DOES NOT CONTAIN POLLUTANT OILS.**

1.6 Checking the product purchased

Before installing the equipment, it is important to check that it was not damaged during transport or storage. Check that all standard components and accessories ordered have been delivered correctly, otherwise contact Elenos s.r.l.

In this case, the package must contain at least the following:

- n°1 piece of equipment from the ET30000-5, ET25000-5, ET20000-5, ET15000-5, ET10000-5, ET5000, ET3500, ET2500 series;
- n°1 "Identification and Quick Start" manual, which we recommend keeping with the product;

It may also contain:

- n°1 "User" manual;
- n°1 CD containing all the documentation relative to Elenos s.r.l. manuals;
- n°1 PC connection cable.

Cables, spare parts and other accessories may be requested from Elenos S.r.l. or Elenos retailers.

2 Product description

2.1 Combiner/Splitter unit

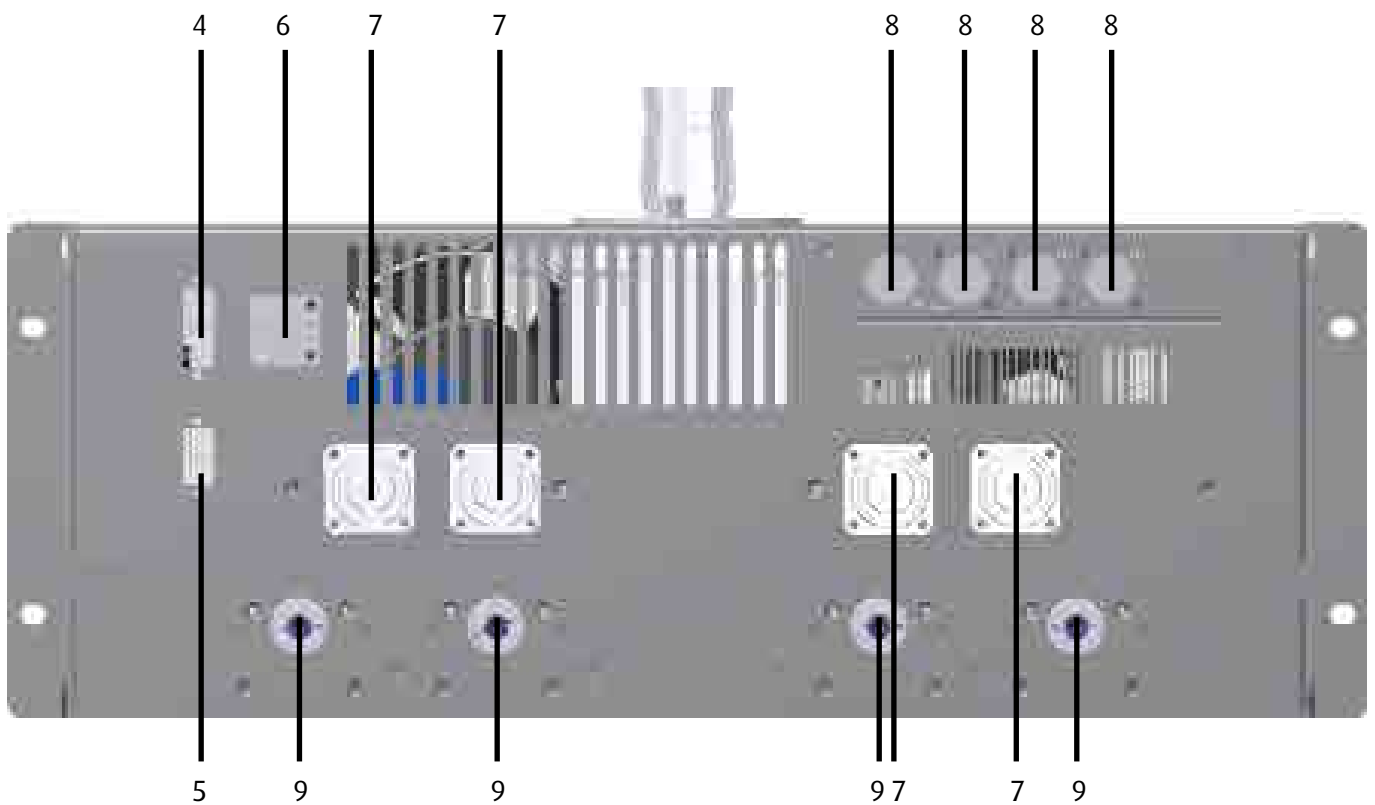
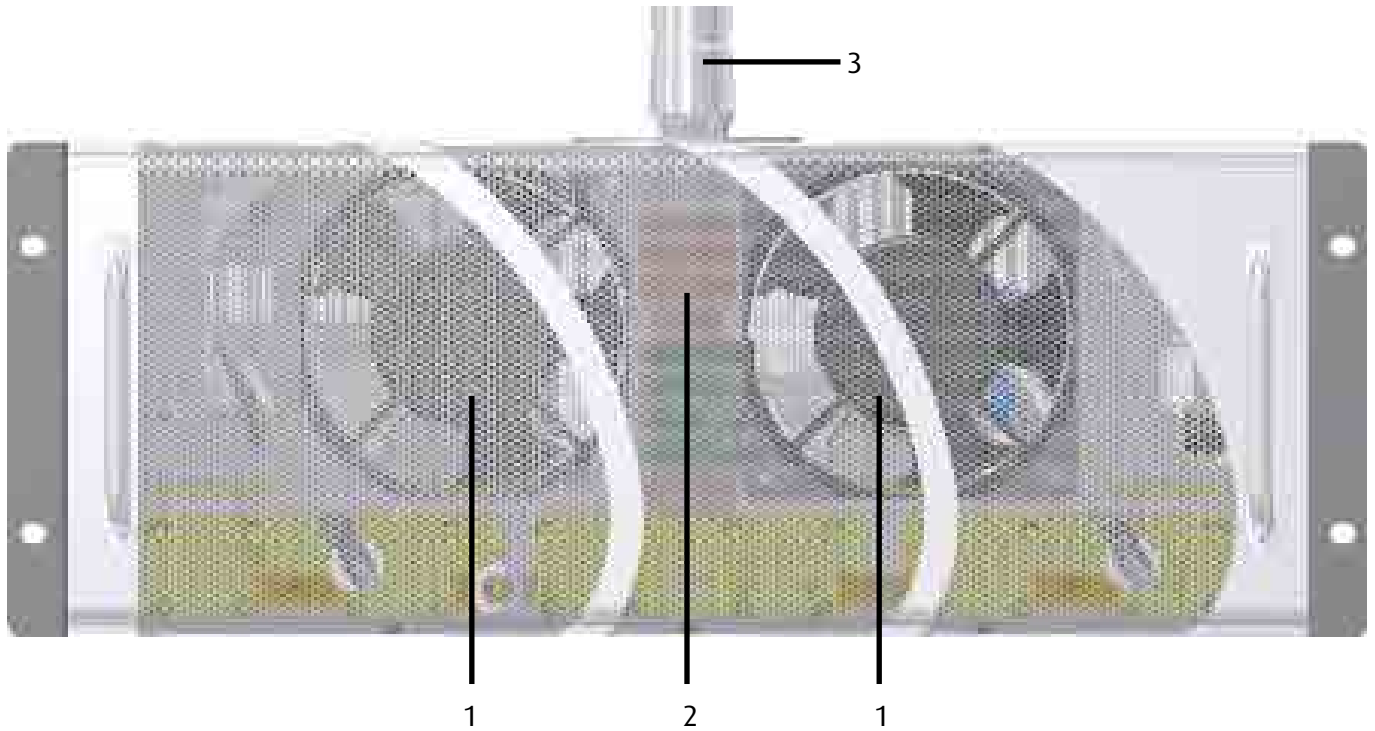

- 1 FAN** - cooling fans. There are two, 12-28Vdc, 306M3/h max.
- 2 GRILL** - ventilation grille.
- 3 RF OUT** - RF output connector 3"+1/8
- 4 PWS** - 3W3 connector for the fan power supply.
- 5 AUX1** - unused connector.
- 6 SPLITTER IN** - N connector for RF splitter input.
- 7 LOAD** - four 7/16 connectors for unbalanced load outputs.
- 8 SPLITTER OUT** - four N connectors for RF splitter outputs.
- 9 POWER IN** - four 7/8 connectors for RF amplifier inputs.

2.2 Control unit (ET30000-5, ET25000-5, ET20000-5)

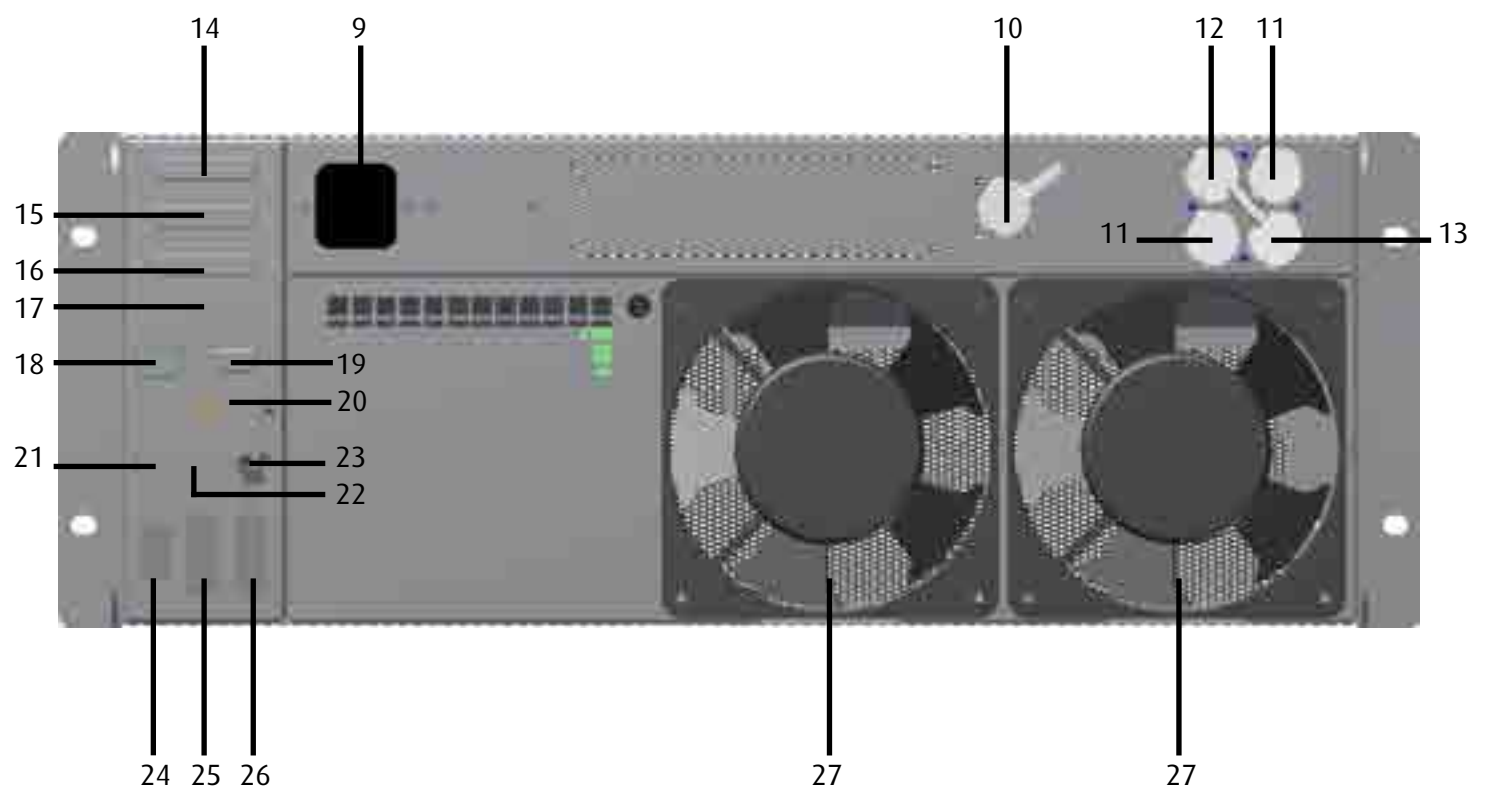
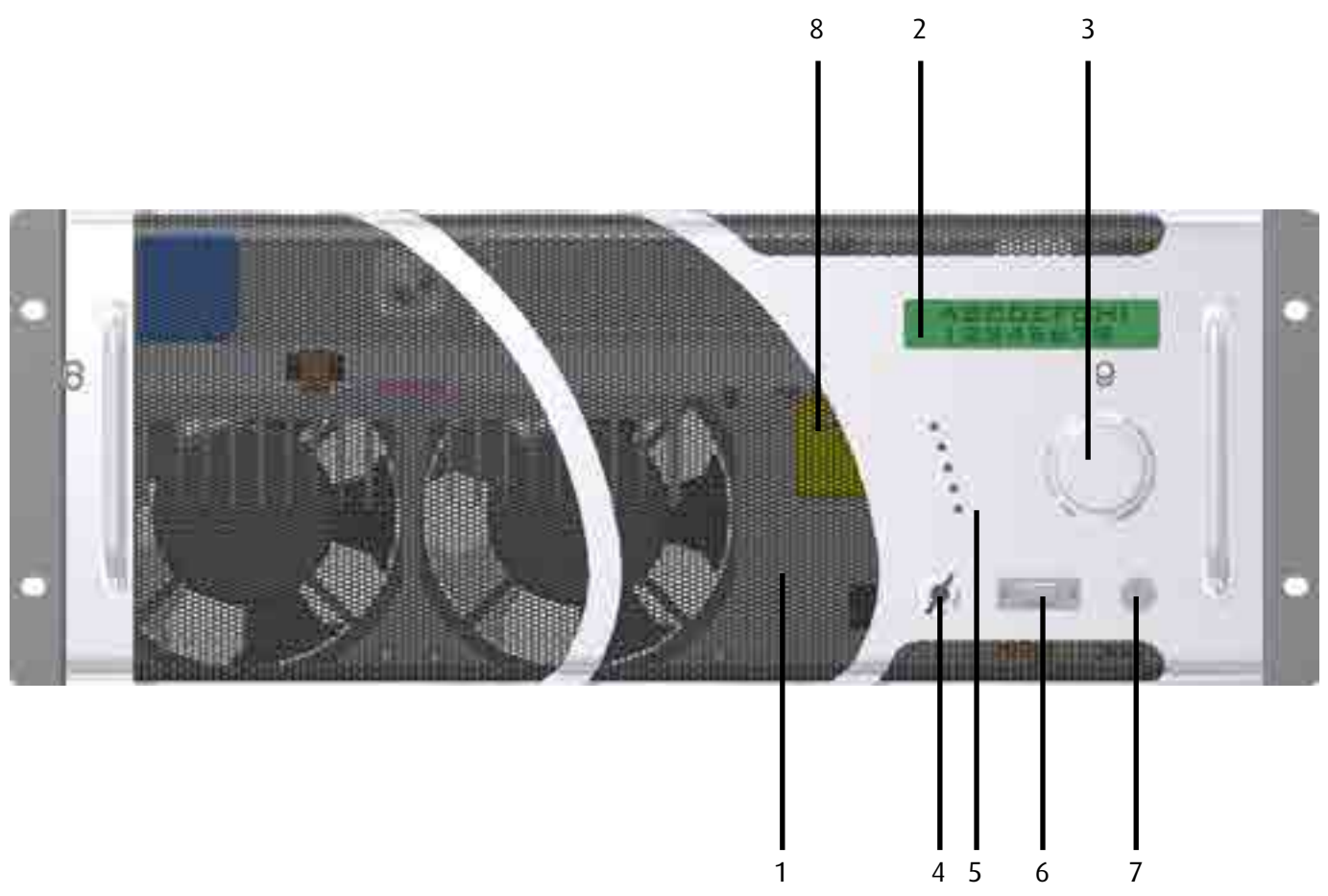

- 1 GRILL** - ventilation grille.
- 2 DISPLAY** - display showing the operating parameters and selected functions using the encoder.
- 3 ENCODER** - multifunction knob allowing navigation through the function menus and modification of the operating parameters.
- 4 KEY SELECTOR** - it can be set to LOCAL (controllable through the front panel) or REMOTE (controllable via PC) mode, by turning the key supplied with the equipment.
- 5 WARNING LIGHTS** - LED list:
- FAULT (red) _ this warning light is on when the equipment is considered to be in "FAILURE";
 - ON AIR (green) _ this warning light is on when the apparatus is broadcasting;
 - ST-BY (yellow) _ this warning light is on when the apparatus is not broadcasting;
 - LOCAL (blue) _ this warning light is on during local programming;
 - MAINS (green) _ this warning light is on when power is supplied.
- 6 INTERFACE** - B9 F connector for connection with telemetry according to the EIA485 standard, or to a PC.
- 7 RF MONITOR** - BNC connector for connection with external measurement tools, allowing to the RF signal to be taken at a low level (0dBm at scale bottom). This monitor is not calibrated, therefore it is not guaranteed that the output level stays constant as frequency changes. *It CANNOT be used for measuring the output power, or for measuring the harmonic components.*
- 9 PROGRAMMING LEVER** - Located on the right hand side of the panel facing the machine. It can be moved by means of a flat screwdriver upwards (in running mode) and downwards (in program mode).
- 9 VDE** - VDE socket for the equipment power supply.
- 10 EXCITER DUMMY LOAD** - N connector for internal unbalanced load input.
- 11 RF IN** - two N connectors for modulator RF inputs.
- 12 RF OUT** - N connector for RF splitter output.
- 13 DUMMY LOAD** - N connector for reserve exciter load.
- 14 PROFILES** - DB25 F connector. Normally unused. It is used for the selection of profiles stored (in the case of apparatus as a reserve).
- 15 TC/TS** - DB25 F connector for remote control and remote telesignalling.
- 16 MASTER** - DB25 F connector for interface with amplifiers and modulators.
- 17 SLAVE** - unused connector.
- 18 INTERLOCK** - unused connector.
- 19 IEEE485** - DB9 F connector for connection with telemetry according to the EIA485 standard.
- 20 AUX 1** - DB9 F connector for environment temperature probe.
- 21 FWD** - BNC connector for forward power input.
- 22 REF** - BNC connector for reflected power input.
- 23 MONITOR** - BNC connector for low level signal input in antenna.
- 24 DUMMY LOAD** - DB9 F connector for unbalanced load connection.
- 25 PWS DUMMY LOAD** - 3W3 connector for the unbalanced load fan power supply.
- 26 PWS COMBINER** - 3W3 connector for combiner fan power supply.
- 27 FAN** - cooling fans. There are two, 12-28Vdc, 306M3/h max.

2.2.1 External connectors pin-out

2.2.1.1 Interface connector

Connector	Pin	Meaning	Notes
With a cable to CN3 on E3K 7A044 board	1	TX_1	Filtered output 485 Differential signal "positive"
	2	/TX_1	Filtered output 485 Differential signal "negative"
	3	RX_1	Filtered input 485 Differential signal "positive"
	4	/RX_1	Filtered input 485 Differential signal "negative"
	5	Common ground	
	6	Common ground	
	7	Common ground	
	8	Common ground	
	9	Common ground	

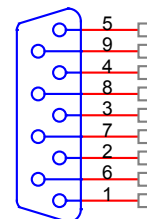

2.2.1.2 Profiles connector

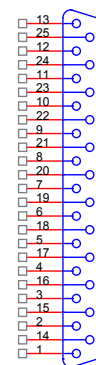

Connector	Pin	Meaning	Notes
CN1 on E10K5A070 board	1	TC_CH1	F_TC_CH0
	2	TC_CH3	F_TC_CH2
	3	TC_CH5	F_TC_CH4
	4	-	No connected
	5	Common ground	
	6	TS_E_M_CH6	Common ground if JP4 is in shot circuit
	7	-	No connected
	8	TS_E_M_CH3	Common ground if JP2 is in shot circuit
	9	Common ground	
	10	Common ground	
	11	TS_CH5	F_TS_CH4
	12	TS_CH	F_TS_CH2
	13	TS_CH1	F_TS_CH0
	14	TC_CH2	F_TC_CH1
	15	TC_CH4	F_TC_CH3
	16	TC_CH6	F_TC_CH5
	17	-	No connected
	18	Common ground	
	19	TS_E_M_CH5	Common ground if JP3 is in shot circuit
	20	TS_E_M_CH4	Common ground if JP1 is in shot circuit
	21	Common ground	
	22	Common ground	
	23	TS_CH6	F_TS_CH5
	24	TS_CH4	F_TS_CH3
	25	TS_CH2	F_TS_CH1

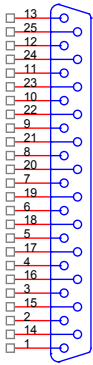

2.2.1.3 TC/TS connector



Connector	Pin	Meaning	Notes
CN1 on E3K NA041board			
	1	Enable (interlock)	Command to state Pin grounded = active command
	2	TX ON	Command pulse Pin grounded = active command
	3	TX OFF	Command pulse Pin grounded = active command
	4	Reflected power	Output in voltage See full scale values
	5	Common ground	Connected to the frame
	6	RX-	Com2 EIA485/422
	7	-	Not connected
	8	TX-	Com2 EIA485/422
	9	Common ground	Connected to the frame
	10	IPA (Current amplifier)	Output in voltage NOT USED
	11	Fault main	Power supply FAULT status The pin must be powered externally. "Open" Status --> Fault active
	12	TX ON	Signaling output The pin must be powered externally. "Closed to ground" status --> TX ON
	13	Warning/Bad audio	Signaling output The pin must be powered externally. "Closed to ground" status --> Active Warning The operation is affected by settings of the machine
	14	Reset alarm	Command pulse Pin grounded = active command
	15	-	Reserved for Elenos
	16	-	Reserved for Elenos
	17	Forward power	Output in voltage See full scale values
	18	Common ground	Connected to the frame
	19	RX+	Com2 EIA485/422
	20	TX+	Com2 EIA485/422
	21	Common ground	Connected to the frame
	22	VPA (Voltage amplifier)	Output in voltage NOT USED

	23	Bad audio	Signaling output The pin must be powered externally. "Closed to ground" status --> Active alarm
	24	/FLT (reversed polarity)	Signaling output The pin must be powered externally. "Open" Status --> Active alarm The operation can be affected by the settings of the machine
	25	Remote	Signaling output The pin must be powered externally. "Closed to ground" status --> Remote signal active

2.2.1.4 Full scale values

The nominal full scale corresponds to +4 V, with over stroke of up to more than +4.5 (max +5 V).

ET30000-5

Parameters	Full scale	Scale factor	Resolution
Forward power	30000W	7500W * V	Full scale/204
Reflected power	3000W	750W * V	

ET25000-5

Parameters	Full scale	Scale factor	Resolution
Forward power	25000W	6250W * V	Full scale/204
Reflected power	2500W	625W * V	

ET20000-5

Parameters	Full scale	Scale factor	Resolution
Forward power	20000W	5000W * V	Full scale/204
Reflected power	2000W	500W * V	

ET15000-5

Parameters	Full scale	Scale factor	Resolution
Forward power	15000W	3750W * V	Full scale/204
Reflected power	1500W	375W * V	

ET10000-5

Parameters	Full scale	Scale factor	Resolution
Forward power	10000W	2500W * V	Full scale/204
Reflected power	1000W	250W * V	

2.2.1.5 Master connector

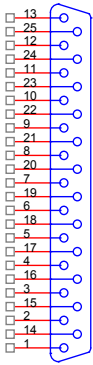

Connector	Pin	Meaning	Notes
CN2 on E3K NA041 board	1	TS_INTLCK	Interlock
	2	TS_FLTAUDIO_TX1	Fault audio exciter1
	3	-	Free
	4	TC_TX2_STATUS	Status exciter2
	5	TC_TX1_STATUS	Status exciter1
	6	TX0-	
	7	-	Not connected
	8	RX0-	
	9	-	Free
	10	TS_FLTAUDIO_TX2	Fault audio exciter2
	11	TS_COAX_TX1	Interlock exciter1
	12	TS_TX2_OFF	Turn off exciter2
	13	TS_TX1_OFF	Turn off exciter1
	14	TS_ALM_RST	Alarm reset
	15	TS_MOD_ON	Turn on modulation
	16	TC_TX2_FAULT	Fault exciter2
	17	TC_TX1_FAULT	Fault exciter1
	18	Common ground	
	19	TX0+	
	20	RX0+	
	21	Common ground	
	22	-	Not connected
	23	TS_COAX_TX2	Interlock exciter2
	24	TS_TX2_ON	Turn on exciter2
	25	TS_TX1_ON	Turn on exciter1

2.2.1.6 EIA485 connector

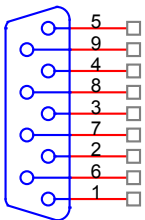

Connector	Pin	Meaning	Notes
CN8 on E3K NA041 board	1	TX1+	Telemetry
	2	TX1-	
	3	RX1+	
	4	RX1-	
	5	Common ground	
	6	Common ground	
	7	Common ground	
	8	Common ground	
	9	Common ground	

2.2.1.7 Aux1 connector

Connector	Pin	Meaning	Notes
With a cable to J9 on E2OK0A912 board	1	+12V	
	2	Common ground	
	3	TEMP	
	4	Common ground	
	5	Not connected	
	6	Not connected	
	7	Not connected	
	8	Not connected	
	9	Not connected	

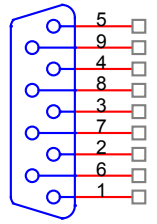

2.2.1.8 Dummy Load connector

Connector	Pin	Meaning	Notes
With a cable to CN5 on E3K FA044 board	1	Common ground	
	2	+12V	
	3	TEMP1	
	4	TEMP2	
	5	TEMP3	
	6	TEMP4	
	7	TEMP5	
	8	TEMP6	
	9	INTERLOCK	

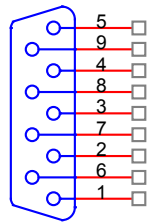

2.3 Control unit (ET15000-5, ET10000-5)

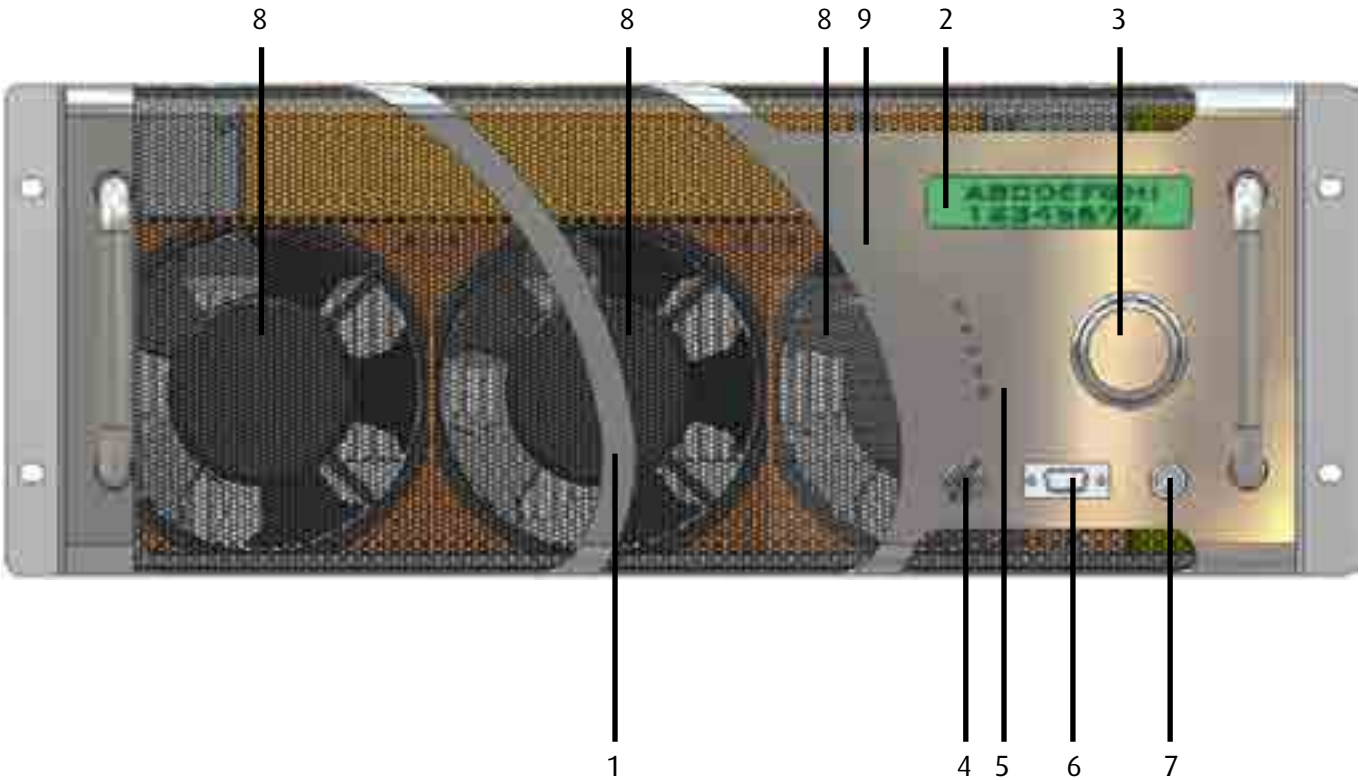

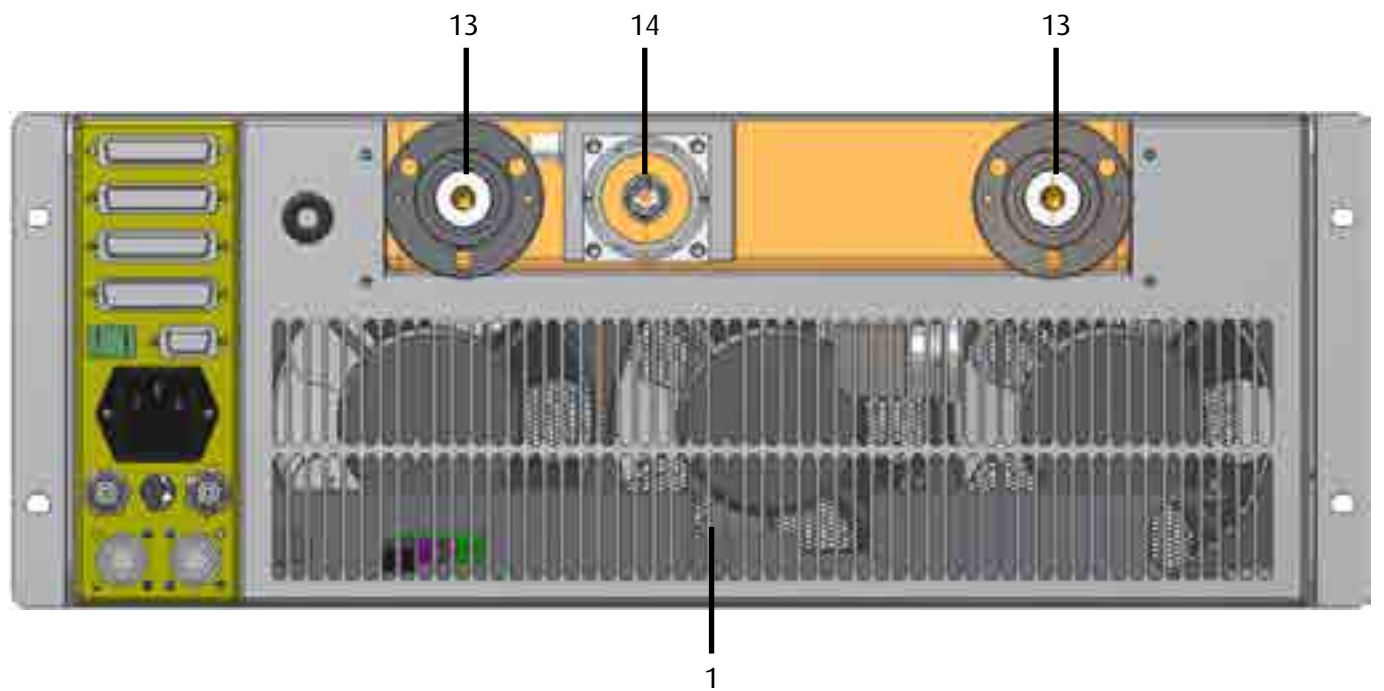
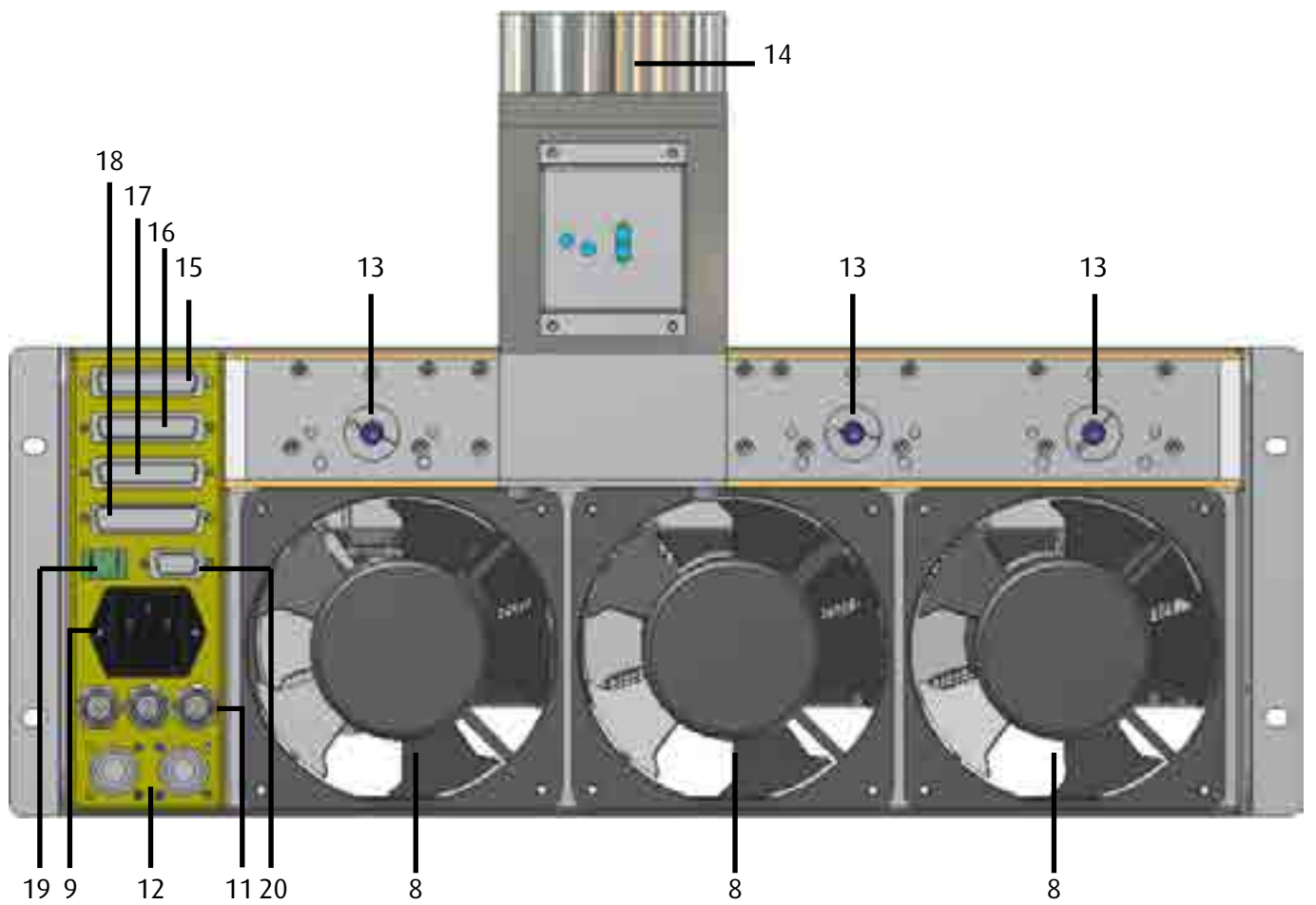

1 GRILL - ventilation grille.

2 DISPLAY - display showing the operating parameters and selected functions using the encoder.

3 ENCODER - multifunction knob allowing navigation through the function menus and modification of the operating parameters.

4 KEY SELECTOR - it can be set to LOCAL (controllable through the front panel) or REMOTE (controllable via PC) mode, by turning the key supplied with the equipment.

5 WARNING LIGHTS - LED list:

- FAULT (red) _ this warning light is on when the equipment is considered to be in "FAILURE";
- ON AIR (green) _ this warning light is on when the apparatus is broadcasting;
- ST-BY (yellow) _ this warning light is on when the apparatus is not broadcasting;
- LOCAL (blue) _ this warning light is on during local programming;
- MAINS (green) _ this warning light is on when power is supplied.

6 INTERFACE - B9 F connector for connection with telemetry according to the EIA485 standard, or to a PC.

7 RF MONITOR - BNC connector for connection with external measurement tools, allowing to the RF signal to be taken at a low level (0dBm at scale bottom). This monitor is not calibrated, therefore it is not guaranteed that the output level stays constant as frequency changes. *It CANNOT be used for measuring the output power, or for measuring the harmonic components.*

8 FAN - cooling fans. There are three on the front panel, 12-28Vdc, 441Mc/h max. There are three on the front panel on the rear panel (only on ET15000-5), 12-28Vdc, 306Mc/h max.

9 PROGRAMMING LEVER - Located on the right hand side of the panel facing the machine. It can be moved by means of a flat screwdriver upwards (in running mode) and downwards (in program mode).

10 VDE - VDE socket for the equipment power supply.

11 SPLITTER OUT CONNECTORS - BNC connector for RF output from splitter. There are two in ET10000-5, three in ET15000-5.

12 EXCITER IN CONNECTORS - N connector for RF input from exciter. There are two.

13 AMPLIFIER IN - 7/8" connector for RF input from amplifiers.

14 RF OUT - 3" 1/8 connector (on ET15000-5), 1" 5/8 (on ET10000-5).

15 PROFILES (see paragraph 2.2.1.2) - DB25 F connector. Normally unused. It is used for the selection of profiles stored (in the case of apparatus as a reserve).

16 TC/TS (see paragraph 2.2.1.3/ 2.2.1.4) - DB25 F connector for remote control and remote telesignalling.

17 MASTER (see paragraph 2.2.1.5) - DB25 F connector for interface with amplifiers and modulators.

18 SLAVE - unused connector.

19 INTERLOCK - unused connector.

20 IEEE485 (see paragraph 2.2.1.6) - DB9 F connector for connection with telemetry according to the EIA485 standard.

2.4 Dummy load

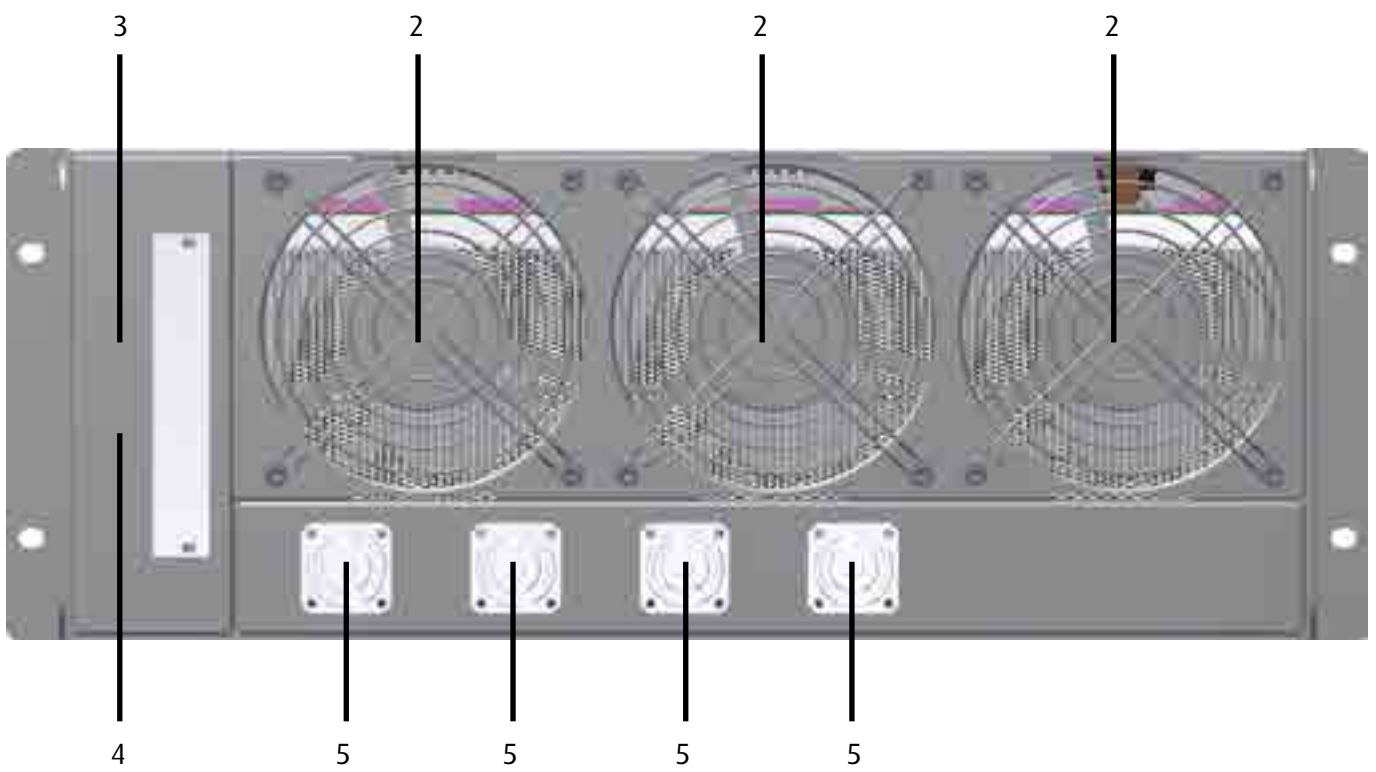
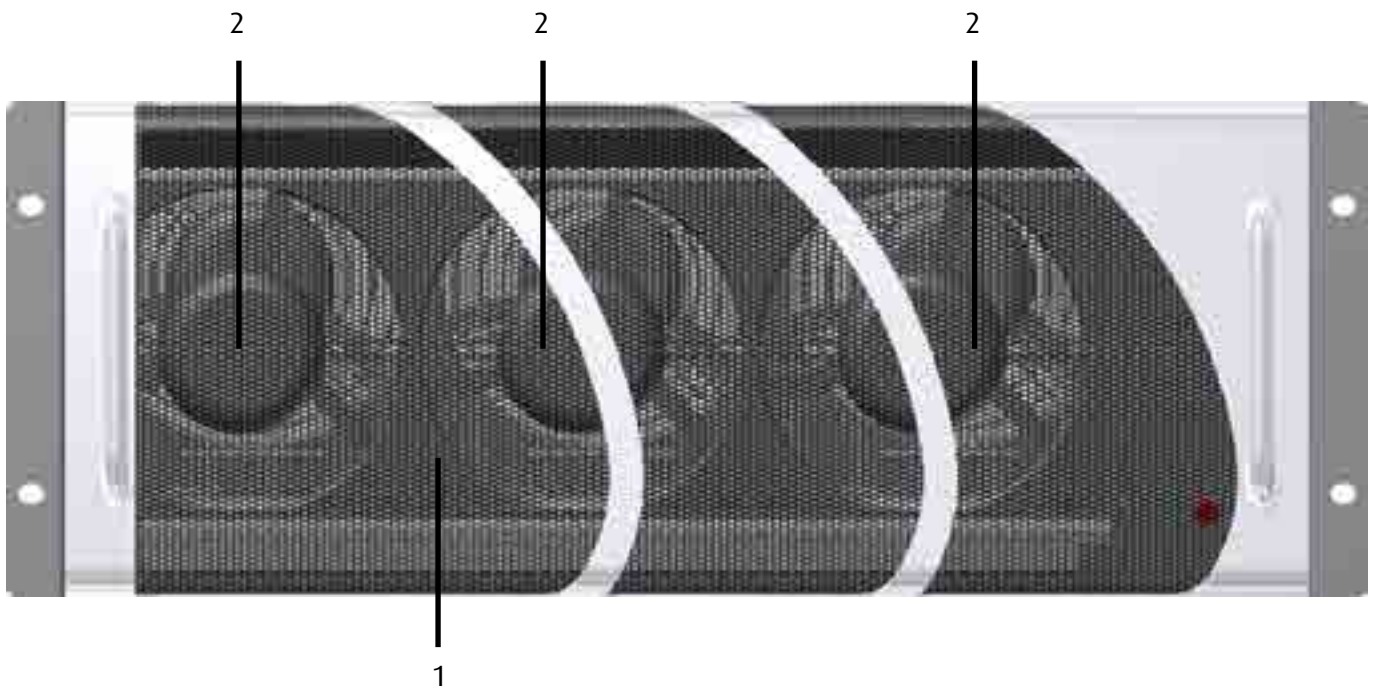

- 1 GRILL** - ventilation grille.
- 2 FAN** - cooling fans. There are six, 12-28Vdc, 441M3/h max.
- 3 DUMMY LOAD** - DB9 M connector for control unit connection.
- 4 PWS DUMMY LOAD** - 3W3 connector for power supply.
- 5 RF IN** - four 7/16 connectors for RF combiner inputs.

2.4.1 External connectors pin-out

2.4.1.1 Dummy Load connector

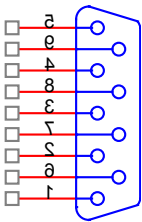

Connector	Pin	Meaning	Notes
CN1 on XNK CA452 board	1	Common ground	
	2	+12V	
	3	TEMP1	
	4	TEMP2	
	5	TEMP3	
	6	TEMP4	
	7	TEMP5	
	8	TEMP6	
	9	INTERLOCK	

2.5 Amplifiers

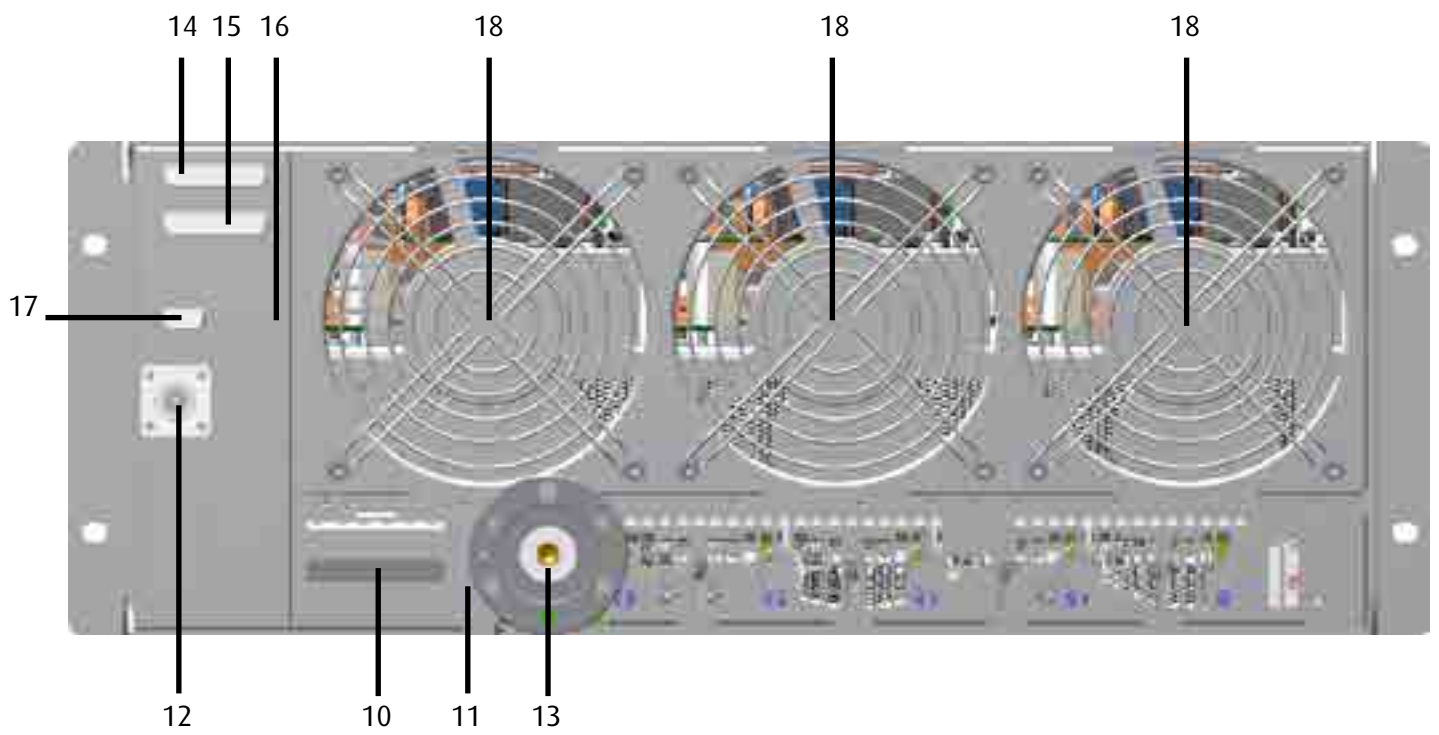
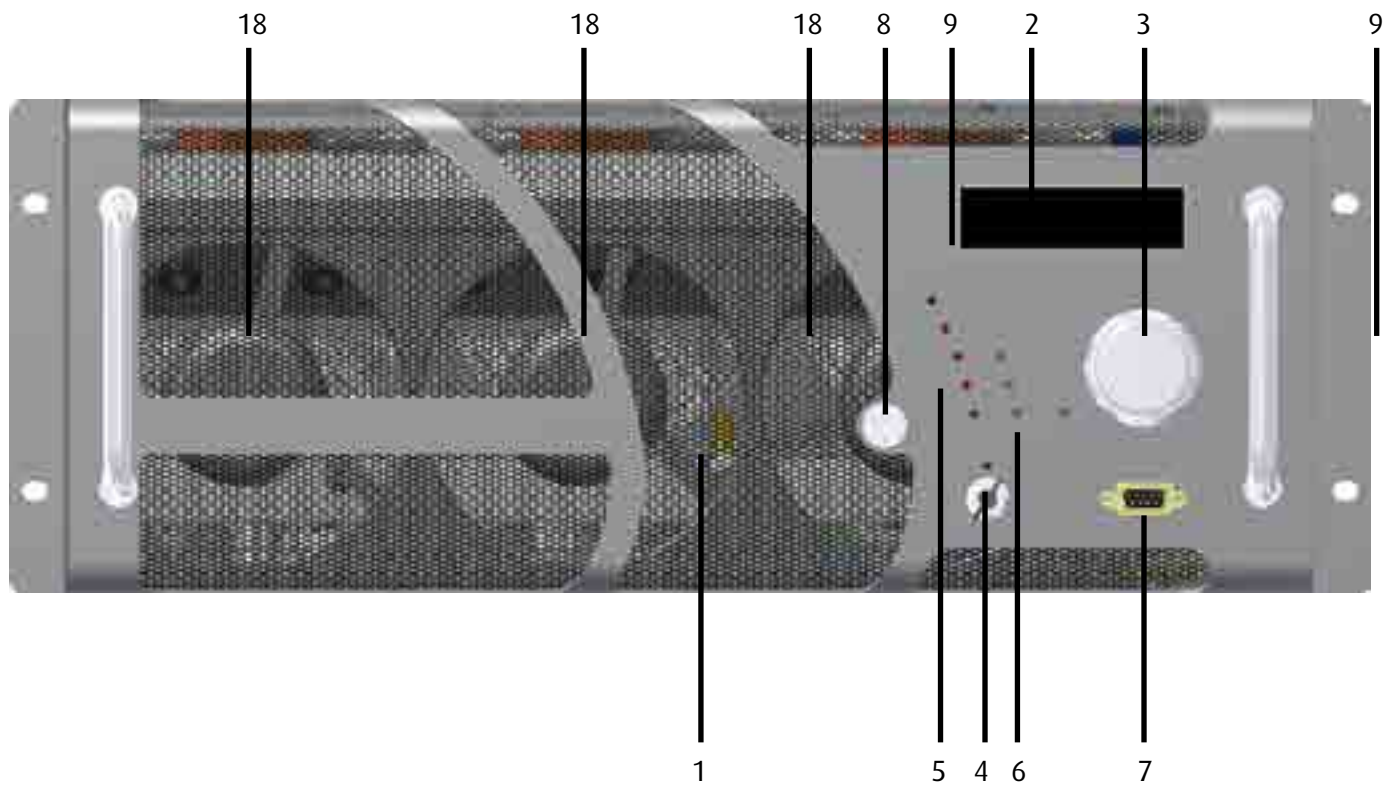

1 GRILL - ventilation grille.

2 DISPLAY - display showing the operating parameters and selected functions using the encoder.

3 ENCODER - multifunction knob allowing navigation through the function menus and modification of the operating parameters.

4 KEY SELECTOR - it can be set to LOCAL (controllable through the front panel) or REMOTE (controllable via PC) mode, by turning the key supplied with the equipment.

5 WARNING LIGHTS - LED list:

- MAINS (green) _ this warning light is on when power is supplied;
- ON AIR (green) _ this warning light is on when the apparatus is broadcasting;
- ST-BY (yellow) _ this warning light is on when the apparatus is not broadcasting;
- EXCITER OK (yellow) _ this warning light is on fixed in conditions of correct driving;
- FAULT (red) _ this warning light is on when the equipment is considered to be in "failure";
- LOCAL (light blue) _ this warning light is on during local programming.

6 BUTTONS/CONTROLS - Button list :

- LIFEXTENDER _ This button displays the state of the LifExtender optional function (active/inactive, days of activity, critical days of activity);
- OFF _ this button allows the equipment to be put on Stand-by;
- ON _ this button allows the equipment to be put On Air;
- ESC _ this button moves the user back previous level in the menu.

7 EIA485/TELEMETRY - DB9 F connector for connection with telemetry according to the EIA485 standard, or with a PC.

8 RF MONITOR - BNC connector for connection with external measurement tools, allowing to collect the RF signal at low level (0dBm at scale bottom).

This monitor is not calibrated, therefore it is not guaranteed that the output level stays constant as the frequency changes.

It CANNOT be used for measuring the output power, nor for measuring the harmonic components.

9 PROGRAMMING LEVER - Located on the right hand side of the panel facing the machine. It can be moved by means of a flat screwdriver upwards (in program mode) and downwards (in running mode). For the detailed loading procedure of the software, ask the manufacturer for the technical bulletin No.125.

10 POWER SUPPLY TERMINAL BOARD - Terminal board with 6 contacts connecting the three internal power supplies. For details of the connection mode, please refer to section "Quick instructions for commissioning".

11 EARTHING SCREW - Eyelet for earthing the equipment, located behind the flange of the output coaxial connector.

12 RF IN - N type.

13 RF OUT - 7/8" type.

14 TC/TS - DB25 F connector for remote control and remote telesignalling.

15 PROFILES - DB25 F connector to be used as reserve equipment in an N+1 system.

16 TCP/IP, RESERVED - Connector for remote connection functions.

17 EIA485 - DB9 F connector for connection with telemetry according to the EIA485 standard.

18 FAN - cooling fans. There are six, 120x120x38 mm, 12-28Vdc, 306Mc/h max.

2.5.1 External connectors pin-out

2.5.1.1 EIA485/TELEMETRY connector

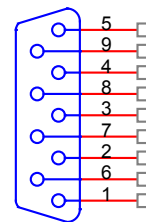

Connector	Pin	Meaning	Notes
CN3 on TG5K2A881 board	1	Com1 TX+	EIA485/422
	2	Com1 TX-	EIA485/422
	3	Com1 RX+	EIA485/422
	4	Com1 RX-	EIA485/422
	5	Common ground	Connected to the frame
	6	Common ground	Connected to the frame
	7	Common ground	Connected to the frame
	8	Common ground	Connected to the frame
	9	Common ground	Connected to the frame

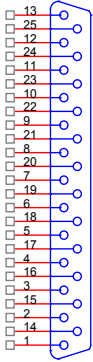

2.5.1.2 TC/TS connector



Connector	Pin	Meaning	Notes
CN1 on TG2U1A899 board			
	1	Enable (interlock)	Command to state Pin grounded = active command
	2	TX ON	Command pulse Pin grounded = active command
	3	TX OFF	Command pulse Pin grounded = active command
	4	Reflected power	Output in voltage See full scale values
	5	Common ground	Connected to the frame
	6	RX-	Com2 EIA485/422
	7	-	Not connected
	8	TX-	Com2 EIA485/422
	9	Common ground	Connected to the frame
	10	IPA (Current amplifier)	Output in voltage See full scale values
	11	Fault main	Power supply FAULT status The pin must be powered externally. "Open" Status → Fault active
	12	TX ON	Signaling output The pin must be powered externally. "Closed to ground" status → TX ON
	13	Warning/Bad audio	Signaling output The pin must be powered externally. "Closed to ground" status → Active Warning The operation is affected by settings of the machine
	14	Reset alarm	Command pulse Pin grounded = active command
	15	UPS target	Command to state
	16	-	Reserved for Elenos
	17	Forward power	Output in voltage See full scale values
	18	Common ground	Connected to the frame
	19	RX+	Com2 EIA485/422
	20	TX+	Com2 EIA485/422
	21	Common ground	Connected to the frame
	22	VPA (Voltage amplifier)	Output in voltage See full scale values

	23	Bad audio	Signaling output The pin must be powered externally. "Closed to ground" status → Active alarm
	24	/FLT (reversed polarity)	Signaling output The pin must be powered externally. "Open" Status → Active alarm The operation can be affected by the settings of the machine
	25	Remote	Signaling output The pin must be powered externally. "Closed to ground" status → Remote signal active

2.5.1.3 PROFILES connector

Connector	Pin	Meaning	Notes
CN1 on TG2U2A899 board	1	Channel 1	Command pulse
	2	Channel 3	Command pulse
	3	Channel 5	Command pulse
	4	Riserve	Command pulse
	5	Common ground	Connected to the frame
	6	Common ground	Connected to the frame
	7	-	Not connected
	8	Common ground	Connected to the frame
	9	Common ground	Connected to the frame
	10	Common ground	Connected to the frame
	11	Channel 5 status	Signaling output
	12	Channel 3 status	Signaling output
	13	Channel 1 status	Signaling output
	14	Channel 2	Command pulse
	15	Channel 4	Command pulse
	16	Channel 6	Command pulse
	17	-	Not connected
	18	Common ground	Connected to the frame
	19	Common ground	Connected to the frame
	20	Common ground	Connected to the frame
	21	Common ground	Connected to the frame
	22	Common ground	Connected to the frame
	23	Channel 6 status	Signaling output
	24	Channel 4 status	Signaling output
	25	Channel 2 status	Signaling output

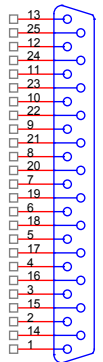

2.5.1.4 TCP/IP, RESERVED connector

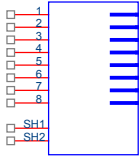

Connector	Pin	Meaning	Notes
CN3 on TG2U2A899 board	1	ETHERNET interface 10Base-T or 100Base-TX	
	2		
	3		
	4		
	5		
	6		
	7		
	8		
CN2 on TG2U2A899 board	1	Reserved	
	2		
	3		
	4		
	5		
	6		
	7		
	8		

2.5.1.5 EIA485 connector

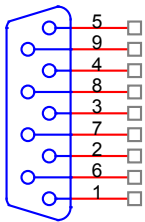

Connector	Pin	Meaning	Notes
CN2 on board TG2U1A899	1	Com1 TX+	EIA485/422
	2	Com1 TX-	EIA485/422
	3	Com1 RX+	EIA485/422
	4	Com1 RX-	EIA485/422
	5	Common ground	Connected to the frame
	6	Common ground	Connected to the frame
	7	Common ground	Connected to the frame
	8	Common ground	Connected to the frame
	9	Common ground	Connected to the frame

2.6 Exciters

For further information, please consult the specific manual for the exciters.

2.7 System connections

For further information, please consult the “Composition” paragraph in the Quick Start manual.

2.8 Technical datasheet



FM TRANSMITTER HIGH POWER | ET30000

FM TRANSMITTER HIGH POWER | ET30000

COMPOSITION	
Exciter (Indium series)	n°1 Exciter Indium Series single drive configuration n°2 Exciter Indium Series dual drive configuration
Amplifier	n°6 Amplifier E5000 Indium Series
Combiner	n°1 6-way combiner IN 5000 - OUT 30000 with external CPU/control unit and load (4U)
Dummy load	n°1 dummy load (4U)
Control unit	n°1 control unit (4U). From the frontal panel/from PC, a careful analysis of the functioning through detailed measurement of currents, voltages, temperatures and powers
RF output connector	3+1/8"
Circuit breaker box	6U (on rear panel)
GENERAL DATA	
Output nominal maximum power	30000 W
Output power range	3000 ÷ 30000 W
Operating band	87.5 ÷ 108 MHz
Dimensions: Rack units	min. 40U
Dimensions: W - H - D	56.5 - 228.2 - 107.8 cm (with fan)
Weight	460 kg
RF power stage technology	ICEFET & ECOSAVING
Automatic power RF control	Stabilized output power value on the set value
Overall output power RF stability	+/- 0.1 dB
Cooling system	Forced air-cooling
Air outlet	On the top. Cooling flow 4000 m3/h (depending on environment)
RS232/RS485	Yes. Connector DB9 female
Points of measure	RF Sample - MPX Monitor
AUDIO PERFORMANCE	
MPX input level	+15/-10 dBu for 75 KHz standard deviation
MPX level adjustment	Soft adjust 0.1 dB steps from front panel
MPX input impedance	5 KΩ selectable
L/R input level	+15/-10 dBu for 75 KHz standard deviation
L/R level adjustment	Soft adjust 0.1 dBu steps from front panel
L/R Input Impedance	Selectable 10 K - 600 Ω, balanced
AES/EBU input resolution	24 bits
AES/EBU input sample rate	32,44.1,48,96 KHz Automatically selected
AES/EBU input level	-20 dBFS - 0 dBFS
AES/EBU input impedance	110 Ω balanced
AES/EBU-Analog input automatic changeover	Yes
PILOT Amplitude adjustment	Soft adjust 0.05% steps from front panel
PILOT Phase adjustment	Soft adjust 0.01 degree steps from front panel
PILOT tone frequency	19 KHz
PILOT tone deviation	Soft adjust +/- 7.5 KHz
PILOT tone frequency stability	+/- 1 Hz
THD+N (stereo/mono operation)	< 0.05% with 75 KHz frequency deviation < 0.05% with 100 KHz frequency deviation 30 Hz to 15 KHz
Pre-emphasis	0/25/50/75 microseconds, selectable
Pre-emphasis tolerance	+/- 0.1 dB
FM S/N (MPX operation)	82 dB 20 Hz to 23 KHz @ 53 KHz - detector RMS
FM S/N CCIR (stereo/mono operation)	> = 72 dB weighted > = 72 dB unweighted 400 Hz, 75 KHz frequency deviation, quasi-peak detector, 50 us de-emphasis
Asynchronous AM S/N unweighted	> = 55 dB a 400 Hz, 75 us de-emphasis
Synchronous AM S/N	> = 50 dB a 400 Hz, 75 us de-emphasis
Amplitude-Frequency characteristic (stereo/mono operation)	+/- 0.1 dB (without pre-emphasis) +/- 0.1 dB (with pre-emphasis) 20 Hz to 15 KHz, @ 400 Hz

FM TRANSMITTER HIGH POWER | ET30000

Stereo Crosstalk (typical)	60 dB @ 400 Hz to 10 KHz
Linear crosstalk	>60 db 20 Hz to 15 KHz
Intermodulation distortion	<0.05% Measured with two of tones 1 KHz & 1.3 KHz, ratio 1:1 at 100% modulation
Class of emission	F3
Stereo emission	According to ITU-R recommendation 450 (pilot tone)

EXCITER PERFORMANCE

PLL lock time	<10 sec
Frequency deviation	+/- 75 KHz 0.1 dB steps adjustable
Maximum frequency deviation	+/- 150 KHz
Frequency stability	1 ppm
RF Frequency steps	10 KHz
Phase Response	+/- 0.1 degree from linear phase; 20 KHz to 100 KHz

INSTALLATION REQUIREMENTS

Power supply	380 V or 400 V, Threephase + neutral wire 50-60 Hz* 210 V, Threephase (WYE without neutral)*
--------------	-------------------------------------------------------------------------------------------------

* to be specified when placing the order

Power consumption (typical)	44 KW
Current consumption (typical @230VAC/Threephase)	110 A
Overall efficiency (typical from - 3 dB to Pman)	68%
Power factor	>0.95
Current consumption (typical @380VAC/Threephase)	64 A

ENVIRONMENT

Temperature range (operating)	-5 ÷ +45 °C, 23 ÷ 113 °F
Temperature range (non operating)	-20 ÷ +55 °C, -4 ÷ 131 °F
Humidity range (operating)	95% @ 40 °C, 104 °F
Humidity range (non operating)	90% @ 55 °C, 131 °F
Altitude range (operating)	<3000 meters / <9840 Feet
Altitude range (non operating)	<15000 meters / < 49200 Feet

TELECONTROL & TELEMETRY

Remote control	Yes
Remote Control at clean contacts	Yes
SNMP option	Yes (external)



Datasheet

FM TRANSMITTER HIGH POWER | ET25000

FM TRANSMITTER HIGH POWER | ET25000

COMPOSITION	
Exciter (Indium series)	n°1 Exciter Indium Series single drive configuration n°2 Exciter Indium Series dual drive configuration
Amplifier	n°5 Amplifier E5000 Indium Series
Combiner	n°1 5-way combiner IN 5000 - OUT 25000 with external CPU/control unit and load (4U)
Dummy load	n°1 dummy load (4U)
Control unit	n°1 control unit (4U). From the frontal panel/from PC, a careful analysis of the functioning through detailed measurement of currents, voltages, temperatures and powers
RF output connector	3+1/8"
Circuit breaker box	6U (on rear panel)
GENERAL DATA	
Output nominal maximum power	25000 W
Output power range	2500 ÷ 25000 W
Operating band	87.5 ÷ 108 MHz
Dimensions: Rack units	min. 40U
Dimensions: W - H - D	56.5 - 228.2 - 107.8 cm (with fan)
Weight	400 kg
RF power stage technology	ICEFET & ECOSAVING
Automatic power RF control	Stabilized output power value on the set value
Overall output power RF stability	+/- 0.1 dB
Cooling system	Forced air-cooling
Air outlet	On the top. Cooling flow 4000 m3/h (depending on environment)
RS232/RS485	Yes. Connector DB9 female
Points of measure	RF Sample - MPX Monitor
AUDIO PERFORMANCE	
MPX input level	+15/-10 dBu for 75 KHz standard deviation
MPX level adjustment	Soft adjust 0.1 dB steps from front panel
MPX input impedance	5 KΩ selectable
L/R input level	+15/-10 dBu for 75 KHz standard deviation
L/R level adjustment	Soft adjust 0.1 dBu steps from front panel
L/R Input Impedance	Selectable 10 K - 600 Ω, balanced
AES/EBU input resolution	24 bits
AES/EBU input sample rate	32,44.1,48,96 KHz Automatically selected
AES/EBU input level	-20 dBFS - 0 dBFS
AES/EBU input impedance	110 Ω balanced
AES/EBU-Analog input automatic changeover	Yes
PILOT Amplitude adjustment	Soft adjust 0.05% steps from front panel
PILOT Phase adjustment	Soft adjust 0.01 degree steps from front panel
PILOT tone frequency	19 KHz
PILOT tone deviation	Soft adjust +/- 7.5 KHz
PILOT tone frequency stability	+/- 1 Hz
THD+N (stereo/mono operation)	< 0.05% with 75 KHz frequency deviation < 0.05% with 100 KHz frequency deviation 30 Hz to 15 KHz
Pre-emphasis	0/25/50/75 microseconds, selectable
Pre-emphasis tolerance	+/- 0.1 dB
FM S/N (MPX operation)	82 dB 20 Hz to 23 KHz @ 53 KHz - detector RMS
FM S/N CCIR (stereo/mono operation)	> = 72 dB weighted > = 72 dB unweighted 400 Hz, 75 KHz frequency deviation, quasi-peak detector, 50 us de-emphasis
Asynchronous AM S/N unweighted	> = 55 dB a 400 Hz, 75 us de-emphasis
Synchronous AM S/N	> = 50 dB a 400 Hz, 75 us de-emphasis
Amplitude-frequency characteristic (stereo/mono operation)	+/- 0.1 dB (without pre-emphasis) +/- 0.1 dB (with pre-emphasis) 20 Hz to 15 KHz, @ 400 Hz

FM TRANSMITTER HIGH POWER | ET25000

Stereo Crosstalk (typical)	60 dB @ 400 Hz to 10 KHz
Linear crosstalk	>60 db 20 Hz to 15 KHz
Intermodulation distortion	<0.05% Measured with two of tones 1 KHz & 1.3 KHz, ratio 1:1 at 100% modulation
Class of emission	F3
Stereo emission	According to ITU-R recommendation 450 (pilot tone)

EXCITER PERFORMANCE

PLL lock time	<10 sec
Frequency deviation	+/- 75 KHz 0.1 dB steps adjustable
Maximum frequency deviation	+/- 150 KHz
Frequency stability	1 ppm
RF Frequency steps	10 KHz
Phase Response	+/- 0.1 degree from linear phase; 20 KHz to 100 KHz

INSTALLATION REQUIREMENTS

Power supply	380 V or 400 V, Threephase + neutral wire 50-60 Hz* 210 V, Threephase (WYE without neutral)*
	* to be specified when placing the order
Power consumption	37 KW
Current consumption @230VAC/Threephase	92 A
Overall efficiency (typical from - 3 dB to Pman)	68%
Power factor	>0.95
Current consumption @380VAC/Threephase	53 A

ENVIRONMENT

Temperature range (operating)	-5 ÷ +45 °C, 23 ÷ 113 °F
Temperature range (non operating)	-20 ÷ +55 °C, -4 ÷ 131 °F
Humidity range (operating)	95% @ 40 °C, 104 °F
Humidity range (non operating)	90% @ 55 °C, 131 °F
Altitude range (operating)	<3000 meters / <9840 Feet
Altitude range (non operating)	<15000 meters / < 49200 Feet

TELECONTROL & TELEMETRY

Remote control	Yes
Remote Control at clean contacts	Yes
SNMP option	Yes (external)



Datasheet

FM TRANSMITTER HIGH POWER | ET20000

FM TRANSMITTER HIGH POWER | ET20000

COMPOSITION	
Exciter (Indium series)	n°1 Exciter Indium Series single drive configuration n°2 Exciter Indium Series dual drive configuration
Amplifier	n°4 Amplifier E5000 Indium Series
Combiner	n°1 4-way combiner IN 5000 - OUT 20000 with external CPU/control unit and load (4U)
Dummy load	n°1 dummy load (4U)
Control unit	n° 1 control unit (4U). From the frontal panel/ from PC, a careful analysis of the functioning through detailed measurement of currents, voltages, temperatures and powers
RF output connector	3+1/8"
Circuit breaker box	6U (on front or rear panel on demand)
GENERAL DATA	
Output nominal maximum power	20000 W
Output power range	1500 ÷ 20000 W
Operating band	87.5 ÷ 108 MHz
Dimensions: Rack units	min. 32U
Dimensions: W - H - D	56.5 - 192.5 - 107.8 cm (with fan)
Weight	370 kg
RF power stage technology	ICEFET & ECOSAVING
Automatic power RF control	Stabilized output power value on the set value
Overall output power RF stability	+/- 0.1 dB
Cooling system	Forced air-cooling
Air outlet	On the top. Cooling flow 4000 m3/h (depending on environment)
RS232/RS485	Yes. Connector DB9 female
Points of measure	RF Sample - MPX Monitor
AUDIO PERFORMANCE	
MPX input level	+15/-10 dBu for 75 KHz standard deviation
MPX level adjustment	Soft adjust 0.1 dB steps from front panel
MPX input impedance	5 KΩ selectable
L/R input level	+15/-10 dBu for 75 KHz standard deviation
L/R level adjustment	Soft adjust 0.1 dBu steps from front panel
L/R Input Impedance	Selectable 10 K - 600 Ω, balanced
AES/EBU input resolution	24 bits
AES/EBU input sample rate	32,44.1,48,96 KHz Automatically selected
AES/EBU input level	-20 dBFS - 0 dBFS
AES/EBU input impedance	110 Ω balanced
AES/EBU-Analog input automatic changeover	Yes
PILOT Amplitude adjustment	Soft adjust 0.05% steps from front panel
PILOT Phase adjustment	Soft adjust 0.01 degree steps from front panel
PILOT tone frequency	19 KHz
PILOT tone deviation	Soft adjust +/- 7.5 KHz
PILOT tone frequency stability	+/- 1 Hz
THD+N (stereo/mono operation)	< 0.05% with 75 KHz frequency deviation < 0.05% with 100 KHz frequency deviation 30 Hz to 15 KHz
Pre-emphasis	0/25/50/75 microseconds, selectable
Pre-emphasis tolerance	+/- 0.1 dB
FM S/N (MPX operation)	82 dB 20 Hz to 23 KHz @ 53 KHz - detector RMS
FM S/N CCIR (stereo/mono operation)	> = 72 dB weighted > = 72 dB unweighted 400 Hz, 75 KHz frequency deviation, quasi-peak detector, 50 us de-emphasis
Asynchronous AM S/N unweighted	> = 55 dB a 400 Hz, 75 us de-emphasis
Synchronous AM S/N	> = 50 dB a 400 Hz, 75 us de-emphasis
Amplitude-frequency characteristic (stereo/mono operation)	+/- 0.1 dB (without pre-emphasis) +/- 0.1 dB (with pre-emphasis) 20 Hz to 15 KHz, @ 400 Hz

FM TRANSMITTER HIGH POWER | ET20000

Stereo Crosstalk (typical)	60 dB @ 400 Hz to 10 KHz
Linear crosstalk	>60 db 20 Hz to 15 KHz
Intermodulation distortion	<0.05% Measured with two of tones 1 KHz & 1.3 KHz, ratio 1:1 at 100% modulation
Class of emission	F3
Stereo emission	According to ITU-R recommendation 450 (pilot tone)

EXCITER PERFORMANCE

PLL lock time	<10 sec
Frequency deviation	+/- 75 KHz 0.1 dB steps adjustable
Maximum frequency deviation	+/- 150 KHz
Frequency stability	1 ppm
RF Frequency steps	10 KHz
Phase Response	+/- 0.1 degree from linear phase; 20 KHz to 100 KHz

INSTALLATION REQUIREMENTS

Power supply	380 V or 400 V, Threephase + neutral wire 50-60 Hz* 210 V, Threephase (WYE without neutral)* * to be specified when placing the order
Power consumption	29 KW
Current consumption @230VAC/Threephase	73 A
Overall efficiency (typical from - 3 dB to Pman)	68%
Power factor	>0.95
Current consumption @380VAC/Threephase	43 A

ENVIRONMENT

Temperature range (operating)	-5 ÷ +45 °C, 23 ÷ 113 °F
Temperature range (non operating)	-20 ÷ +55 °C, -4 ÷ 131 °F
Humidity range (operating)	95% @ 40 °C, 104 °F
Humidity range (non operating)	90% @ 55 °C, 131 °F
Altitude range (operating)	<3000 meters / <9840 Feet
Altitude range (non operating)	<15000 meters / < 49200 Feet

TELECONTROL & TELEMETRY

Remote control	Yes
Remote Control at clean contacts	Yes
SNMP option	Yes (external)



Datasheet

FM TRANSMITTER HIGH POWER | ET15000

FM TRANSMITTER HIGH POWER | ET15000

COMPOSITION	
Exciter (Indium series)	n°1 Exciter Indium Series single drive configuration n°2 Exciter Indium Series dual drive configuration
Amplifier	n°3 Amplifier E5000 Indium Series
Combiner/Control unit	n°1 3-Way Combiner IN 5000 - OUT 15000 with an internal load composed by 3 group of 6 resistance of 800 W 50 Ω
RF output connector	3+1/8"
Circuit breaker box	4U (on front or rear panel on demand)
GENERAL DATA	
Output nominal maximum power	15000 W
Output power range	1500 ÷ 15000 W
Operating band	87.5 ÷ 108 MHz
Dimensions: Rack units	min. 32U
Dimensions: W - H - D	56.5 - 160.3 - 107.8 cm
Weight	320 kg
RF power stage technology	ICEFET & ECOSAVING
Automatic power RF control	Stabilized output power value on the set value
Overall output power RF stability	+/- 0.1 dB
Cooling system	Forced air-cooling
Air outlet	On the top. Cooling flow 3250 /4500 m3/h (depending on environment)
RS232/RS485	Yes. Connector DB9 female
Points of measure	RF Sample - MPX Monitor
AUDIO PERFORMANCE	
MPX input level	+15/-10 dBu for 75 KHz standard deviation
MPX level adjustment	Soft adjust 0.1 dB steps from front panel
MPX input impedance	5 KΩ selectable
L/R input level	+15/-10 dBu for 75 KHz standard deviation
L/R level adjustment	Soft adjust 0.1 dBu steps from front panel
L/R Input Impedance	Selectable 10 K - 600 Ω, balanced
AES/EBU input resolution	24 bits
AES/EBU input sample rate	32,44.1,48,96 KHz Automatically selected
AES/EBU input level	-20 dBFS - 0 dBFS
AES/EBU input impedance	110 Ω balanced
AES/EBU-Analog input automatic changeover	Yes
PILOT Amplitude adjustment	Soft adjust 0.05% steps from front panel
PILOT Phase adjustment	Soft adjust 0.01 degree steps from front panel
PILOT tone frequency	19 KHz
PILOT tone deviation	Soft adjust +/- 7.5 KHz
PILOT tone frequency stability	+/- 1 Hz
THD+N (stereo/mono operation)	< 0.05% with 75 KHz frequency deviation < 0.05% with 100 KHz frequency deviation 30 Hz to 15 KHz
Pre-emphasis	0/25/50/75 microseconds, selectable
Pre-emphasis tolerance	+/- 0.1 dB
FM S/N (MPX operation)	82 dB 20 Hz to 23 KHz @ 53 KHz - detector RMS
FM S/N CCIR (stereo/mono operation)	> = 72 dB weighted > = 72 dB unweighted 400 Hz, 75 kHz frequency deviation, quasi-peak detector, 50 us de-emphasis
Asynchronous AM S/N unweighted	> = 55 dB a 400 Hz, 75 us de-emphasis
Synchronous AM S/N	> = 50 dB a 400 Hz, 75 us de-emphasis
Amplitude-frequency characteristic (stereo/mono operation)	+/- 0.1 dB (without pre-emphasis) +/- 0.1 dB (with pre-emphasis) 20 Hz to 15 KHz, @ 400 Hz
Stereo Crosstalk (typical)	60 dB @ 400 Hz to 10 KHz
Linear crosstalk	>60 db 20 Hz to 15 KHz
Intermodulation distortion	<0.05% Measured with two of tones 1 KHz & 1.3 KHz, ratio 1:1 at 100% modulation

FM TRANSMITTER HIGH POWER | ET15000

Class of emission	F3
Stereo emission	According to ITU-R recommendation 450 (pilot tone)
EXCITER PERFORMANCE	
PLL lock time	<10 sec
Frequency deviation	+/- 75 KHz 0.1 dB steps adjustable
Maximum frequency deviation	+/- 150 KHz
Frequency stability	1 ppm
RF Frequency steps	10 KHz
Phase Response	+/- 0.1 degree from linear phase; 20 KHz to 100 KHz
INSTALLATION REQUIREMENTS	
Power supply	380 V or 400 V, Threephase + neutral wire 50-60 Hz* 210 V, Threephase (WYE without neutral)*
	* to be specified when placing the order
Power consumption	22 KW
Current consumption @230VAC/Threephase	63 A
Overall efficiency (typical from - 3 dB to Pman)	68%
Power factor	>0.95
Current consumption @380VAC/Threephase	36 A
ENVIRONMENT	
Temperature range (operating)	-5 + +45 °C, 23 + 113 °F
Temperature range (non operating)	-20 + +55 °C, -4 + 131 °F
Humidity range (operating)	95% @ 40 °C, 104 °F
Humidity range (non operating)	90% @ 55 °C, 131 °F
Altitude range (operating)	<3000 meters / <9840 Feet
Altitude range (non operating)	<15000 meters / < 49200 Feet
TELECONTROL & TELEMETRY	
Remote control	Yes
Remote Control at clean contacts	Yes
SNMP option	Yes (external)



Datasheet

FM TRANSMITTER HIGH POWER | ET10000

FM TRANSMITTER HIGH POWER | ET10000

COMPOSITION	
Exciter (Indium series)	n°1 Exciter Indium Series single drive configuration n°2 Exciter Indium Series dual drive configuration
Amplifier	n°2 Amplifier E5000 Indium Series
Combiner/Control unit	n°1 2-way combiner IN 5000 - OUT 10000 with an internal load composed by 1 group of 6 resistance of 800 W 50 Ω
RF output connector	1+5/8"
Circuit breaker box	4U (on front or rear panel on demand)
GENERAL DATA	
Output nominal maximum power	10000 W
Output power range	1500 ÷ 10000 W
Operating band	87.5 ÷ 108 MHz
Dimensions: Rack units	min. 20U
Dimensions: W - H - D	56.5 - 105 - 107.8cm
Weight	270 kg
RF power stage technology	ICEFET & ECOSAVING
Automatic power RF control	Stabilized output power value on the set value
Overall output power RF stability	+/- 0.1 dB
Cooling system	Forced air-cooling
Air outlet	On the top or on the rear. Cooling flow 2200 /2400 m3/h (depending on environment)
RS232/RS485	Yes. Connector DB9 Female
Points of measure	RF Sample - MPX Monitor
AUDIO PERFORMANCE	
MPX input level	+15/-10 dBu for 75 KHz standard deviation
MPX level adjustment	Soft adjust 0.1 dB steps from front panel
MPX input impedance	5 KΩ selectable
L/R input level	+15/-10 dBu for 75 KHz standard deviation
L/R level adjustment	Soft adjust 0.1 dBu steps from front panel
L/R Input Impedance	Selectable 10 K - 600 Ω, balanced
AES/EBU input resolution	24 bits
AES/EBU input sample rate	32,44.1,48,96 KHz Automatically selected
AES/EBU input level	-20 dBFS - 0 dBFS
AES/EBU input impedance	110 Ω balanced
AES/EBU-Analog input automatic changeover	Yes
PILOT Amplitude adjustment	Soft adjust 0.05% steps from front panel
PILOT Phase adjustment	Soft adjust 0.01 degree steps from front panel
PILOT tone frequency	19 KHz
PILOT tone deviation	Soft adjust +/- 7.5 KHz
PILOT tone frequency stability	+/- 1 Hz
THD+N (stereo/mono operation)	< 0.05% with 75 KHz frequency deviation < 0.05% with 100 KHz frequency deviation 30 Hz to 15 KHz
Pre-emphasis	0/25/50/75 microseconds, selectable
Pre-emphasis tolerance	+/- 0.1 dB
FM S/N (MPX operation)	82 dB 20 Hz to 23 KHz @ 53 KHz - detector RMS
FM S/N CCIR (stereo/mono operation)	> = 72 dB weighted > = 72 dB unweighted 400 Hz, 75 KHz frequency deviation, quasi-peak detector, 50 us de-emphasis
Asynchronous AM S/N unweighted	> = 55 dB a 400 Hz, 75 us de-emphasis
Synchronous AM S/N	> = 50 dB a 400 Hz, 75 us de-emphasis
Amplitude-frequency characteristic (stereo/mono operation)	+/- 0.1 dB (without pre-emphasis) +/- 0.1 dB (with pre-emphasis) 20 Hz to 15 KHz, @ 400 Hz
Stereo Crosstalk (typical)	60 dB @ 400 Hz to 10 KHz
Linear crosstalk	>60 db 20 Hz to 15 KHz
Intermodulation distortion	<0.05% Measured with two of tones 1 KHz & 1.3 KHz, ratio 1:1 at 100% modulation

FM TRANSMITTER HIGH POWER | ET10000

Class of emission	F3
Stereo emission	According to ITU-R recommendation 450 (pilot tone)
EXCITER PERFORMANCE	
PLL lock time	<10 sec
Frequency deviation	+/- 75 KHz 0.1 dB steps adjustable
Maximum frequency deviation	+/- 150 KHz
Frequency stability	1 ppm
RF Frequency steps	10 KHz
Phase Response	+/- 0.1 degree from linear phase; 20 KHz to 100 KHz
INSTALLATION REQUIREMENTS	
Power supply	380 V or 400 V, Threephase + neutral wire 50-60 Hz* 210 V, Threephase (WYE without neutral)*
	* to be specified when placing the order
Power consumption	15 KW
Current consumption @230VAC/Threephase	42 A
Overall efficiency (typical from - 3 dB to Pman)	68%
Power factor	>0.95
Current consumption @380VAC/Threephase	24 A
ENVIRONMENT	
Temperature range (operating)	-5 + +45 °C, 23 + 113 °F
Temperature range (non operating)	-20 + +55 °C, -4 + 131 °F
Humidity range (operating)	95% @ 40 °C, 104 °F
Humidity range (non operating)	90% @ 55 °C, 131 °F
Altitude range (operating)	<3000 meters / <9840 Feet
Altitude range (non operating)	<15000 meters / < 49200 Feet
TELECONTROL & TELEMETRY	
Remote control	Yes
Remote Control at clean contacts	Yes
SNMP option	Yes (external)



Datasheet

FM AMPLIFIER MEDIUM POWER | E5000

E5000

FM AMPLIFIER MEDIUM POWER

GENERAL DATA	
Output Nominal Power	5000 W adjustable
Operating band	87.5 ÷ 108 MHz
RS232/RS485	Yes. Connector DB9 female
Points of measure	RF Sample - MPX Monitor
Displayed Parameters	More than 50 parameters displayed on a wide graphic 0-LED screen
Adjustments	From the frontal panel through OLED/from PC
Number of L-DMOS in amplifier stage	7
RF power stage technology	ICEFET & ECOSAVING
Dimensions: Rack units	4U
Dimensions: W - H - D	48.5 - 17.6 - 70 cm
Weight	35 Kg
Number of power supplies	3
Number of cooling fans	6
CONNECTORS	
RF Output connector	7/8
RF Input connector	N
RF PERFORMANCE	
Output impedance	50 Ω
Automatic power RF control	Stabilizes the output power value on the set value
Overall output power RF stability	+/- 0,1 dB
VSWR	2:1 at full power. Automatic power reduction beyond 1.7:1. Transmitter is protected fro open and short circuit.
Harmonics	< -75 dBc
Out of band emission (spurious)	< -80 dBc
AUDIO AND EXCITER PERFORMANCE	
Driving power	2W *
INSTALLATION REQUIREMENTS	
Power supply	230/400 Threephase-Singlephase Version 50-60 Hz VAC
Power consumption (typical)	7.1 KW

* Elenos suggests to drive this amplifier with ET620 Elenos Indium Series

FM AMPLIFIER MEDIUM POWER | E5000

Overall efficiency (typical from -3dB to Pnom)	> = 70%
Power factor	> 0.95
Current Consumption @ 230VAC/single phase	31 Amp
Magneto-thermic capacity @ 230VAC/single phase	45 Amp
Conductor size @ 230VAC/single phase	10 sqrt.mm
Conductor size @ 230VAC/single phase	7 AWG
Current Consumption @ 230VAC/three phase	18.5 Amp
Magneto-thermic capacity @ 230VAC/three phase	32 Amp
Conductor size @ 230VAC/three phase	6 sqrt.mm
Conductor size @ 230VAC/three phase	9 AWG
Current Consumption @ 400VAC/three phase	10.5 Amp
Magneto-thermic capacity @ 400VAC/three phase	20 Amp
Conductor size @ 400VAC/three phase	4 sqrt.mm
Conductor size @ 400VAC/three phase	11 AWG

COOLING/NOISE/DATA

Cooling system	Forced air-cooling . From 600 to 1200 m3/h
Air temperature increase	17 °C
Acoustic noise	< 65 phon @ transmitter room, 2 m distance of the front of transmitter

ENVIRONMENT

Temperature range (operating)	-5 ÷ +45 °C, 23 ÷ 113 °F
Temperature range (non operating)	-20 ÷ +55 °C, -4 ÷ 131 °F
Humidity range (operating)	95% @ 40 °C, 104 °F
Humidity range (non operating)	90% @ 55 °C, 131 °F
Altitude range (operating)	<3000 meters / <9840 Feet
Altitude range (non operating)	<15000 meters / < 49200 Feet

TELECONTROL & TELEMETRY

Remote control	Yes
Remote control, dry contacts	Yes
SNMP option	Yes (external)



Datasheet

FM AMPLIFIER MEDIUM POWER | E3500

E3500

FM AMPLIFIER MEDIUM POWER

GENERAL DATA	
Output Nominal Power	3500 W adjustable
Operating band	87.5 ÷ 108 MHz
RS232/RS485	Yes. Connector DB9 femate
Points of measure	RF Sample - MPX Monitor
Displayed Parameters	More than 50 parameters displayed on a wide graphic OLED
Adjustments	From the frontal panel through OLED/from PC
Number of L-DMOS in amplifier stage	5
RF power stage technology	ICEFET & ECOSAVING
Dimensions: Rack units	4U
Dimensions: W - H - D	48.5 - 17.6 - 70 cm
Weight	35 Kg
Number of power supplies	3
Number of cooling fans	6
CONNECTORS	
RF Output connector	7/8"
RF Input connector	N
RF PERFORMANCE	
Output impedance	50 Ω
Automatic power RF control	Stabilizes the output power value on the set value
Overall output power RF stability	+/- 0,1 dB
VSWR	2:1 at full power. Automatic power reduction beyond 1.7:1. Transmitter is protected fro open and short circuit.
Harmonics	< -75 dBc
Out of band emission (spurious)	< -80 dBc
AUDIO AND EXCITER PERFORMANCE	
Driving power	2W *
INSTALLATION REQUIREMENTS	
Power supply	230/400 Threephase-Singlephase Version 50-60 Hz VAC
Power consumption (typical)	4.9 KW

* Elenos suggests to drive this amplifier with ETG20 Elenos Indium Series

FM AMPLIFIER MEDIUM POWER | E3500

Overall efficiency (typical from -3 dB to Pnom)	> = 70%
Power factor	> 0.95
Current Consumption @ 230VAC/single phase	21.3 Amp
Magneto-thermic capacity @ 230VAC/single phase	32 Amp
Conductor size @ 230VAC/single phase	10 sqrt.mm
Conductor size @ 230VAC/single phase	7 AWG
Current Consumption @ 230VAC/three phase	12.5 Amp
Magneto-thermic capacity @ 230VAC/three phase	20 Amp
Conductor size @ 230VAC/three phase	6 sqrt.mm
Conductor size @ 230VAC/three phase	9 AWG
Current Consumption @ 400VAC/three phase	7.1 Amp
Magneto-thermic capacity @ 400VAC/three phase	16 Amp
Conductor size @ 400VAC/three phase	4 sqrt.mm
Conductor size @ 400VAC/three phase	11 AWG
COOLING/NOISE/DATA	
Cooling system	Forced air-cooling . From 600 to 1200 m3/h
Air temperature increase	17 °C
Acoustic noise	< 65 phon @ transmitter room, 2 m distance of the front of transmitter
ENVIRONMENT	
Temperature range (operating)	-5 ÷ +45 °C, 23 ÷ 113 °F
Temperature range (non operating)	-20 ÷ +55 °C, -4 ÷ 131 °F
Humidity range (operating)	95% @ 40 °C, 104 °F
Humidity range (non operating)	90% @ 55 °C, 131 °F
Altitude range (operating)	<3000 meters / <9840 Feet
Altitude range (non operating)	<15000 meters / < 49200 Feet
TELECONTROL & TELEMETRY	
Remote control	Yes
Remote control, dry contacts	Yes
SNMP option	Yes (external)



Datasheet

FM AMPLIFIER MEDIUM POWER | E2500

E2500

FM AMPLIFIER MEDIUM POWER

GENERAL DATA	
Output Nominal Power	2500 W adjustable
Operating band	87.5 ÷ 108 MHz
RS232/RS485	Yes. Connector DB9 female
Points of measure	RF Sample - MPX Monitor
Displayed Parameters	More than 50 parameters displayed on a wide graphic OLED
Adjustments	From the frontal panel through OLED/from PC
Number of L-DMOS in amplifier stage	4
RF power stage technology	ICEFET & ECOSAVING
Dimensions: Rack units	4U
Dimensions: W - H - D	48.5 - 17.6 - 70 cm
Weight	35 Kg
Number of power supplies	3
Number of cooling fans	6
RF Output connector	7/8"
RF Input connector	N
RF PERFORMANCE	
Output impedance	50 Ω
Automatic power RF control	Stabilizes the output power value on the set value
Overall output power RF stability	+/- 0,1 dB
VSWR	2:1 at full power. Automatic power reduction beyond 1.7:1. Transmitter is protected for open and short circuit.
Harmonics	< -75 dBc
Out of band emission (spurious)	< -80 dBc
AUDIO AND EXCITER PERFORMANCE	
Driving power	2W *
INSTALLATION REQUIREMENTS	
Power supply	230/400 Threephase-Singlephase Version 50-60 Hz VAC
Power consumption (typical)	3.5 KW

* Elenos suggests to drive this amplifier with ET620 Elenos Indium Series

FM AMPLIFIER MEDIUM POWER | E2500

Overall efficiency (typical from -3 dB to Pnom)	> = 70%
Power factor	> 0.95
Current Consumption @ 230VAC/single phase	15 Amp
Magneto-thermic capacity @ 230VAC/single phase	32 Amp
Conductor size @ 230VAC/single phase	6 sqrt.mm
Conductor size @ 230VAC/single phase	9 AWG
Current Consumption @ 230VAC/three phase	9 Amp
Magneto-thermic capacity @ 230VAC/three phase	20 Amp
Conductor size @ 230VAC/three phase	4 sqrt.mm
Conductor size @ 230VAC/three phase	11 AWG
Current Consumption @ 400VAC/three phase	5 Amp
Magneto-thermic capacity @ 400VAC/three phase	10 Amp
Conductor size @ 400VAC/three phase	2.5 sqrt.mm
Conductor size @ 400VAC/three phase	13 AWG
COOLING/NOISE/DATA	
Cooling system	Forced air-cooling . From 600 to 1200 m3/h
Air temperature increase	17 °C
Acoustic noise	< 65 phon @ transmitter room, 2 m distance of the front of transmitter
ENVIRONMENT	
Temperature range (operating)	-5 ÷ +45 °C, 23 ÷ 113 °F
Temperature range (non operating)	-20 ÷ +55 °C, -4 ÷ 131 °F
Humidity range (operating)	95% @ 40 °C, 104 °F
Humidity range (non operating)	90% @ 55 °C, 131 °F
Altitude range (operating)	<3000 meters / <9840 Feet
Altitude range (non operating)	<15000 meters / < 49200 Feet
TELECONTROL & TELEMETRY	
Remote control	Yes
Remote control, dry contacts	Yes
SNMP option	Yes (external)

2.9 Protections

The equipment has an integrated protection system both for the hardware and the software.

2.9.1 Software protections

2.9.1.1 IPF (Intelligent Proportional Foldback)

Mechanism which is activated on the control unit and works on each individual machine.

The IPF is an intelligent system which reduces the equipment's output power in the event of strong load mismatch, thus preventing the machine from turning off.

The activation of this feature is shown on the display as alarm "026" for modulators and "030" for amplifiers.

2.9.1.2 IPC (Intelligent Power Control)

It is provided on the amplifiers in the system.

When the equipment is working properly, the IPC keeps the amplifier output power constant

(and subsequently, the transmitter output power) within $\pm 1\%$ of the target set, irrespective of mains voltage, temperature and load variations.

The IPC also allows the RF section efficiency to be optimized by making the MOSFETs constantly work at maximum efficiency, thus minimizing overall electrical consumption.

2.9.1.3 Safety Management ("Lifextender" option) ®

The Safety Management consists of algorithms which perform a real-time analysis of the transmitter's operating status and operates in order to maintain the output power set, according to the type and severity of any errors (internal or environmental) that may occur.

The Safety Management can control an output power reduction proportional to the severity of the error that arises.

The algorithms act at different levels and in various sections of the equipment: Thermal Management on the RF unit, Thermal Management on Dummy Load, Current Management on the power supply unit, Thermal Management on the power supply unit, Fault management on the RF unit, Fault Management on the power supply unit, Cooling Management on the fan unit.

Thermal Management on the RF unit (Lifextender) ®

It is provided on amplifiers and excitors.

If the temperature measured in the vicinity of the MOSFETs exceeds 72 °C, a first level of derating intervenes slightly in order to reduce the temperature through an output power reduction.

The power reduction is the lowest possible that allows a thermal balance to be reached at a temperature of less than 72 °C.

The output power reduction never exceeds 40% with this first derating. In other words, the output power is always 60% higher than that set by the user, and the "- 3 dB" warning with corresponding alarm does not intervene. This first derating level is effective in virtually all cases.

The activation of this feature is shown on the display as alarm "010".

Should the first level derating be insufficient (extremely rare), a second level intervenes, further reducing the power, thus obtaining a thermal balance status which is compatible with the safe operation of the equipment even if it is below - 3 dB (with subsequent "005" alarm).

If the second derating is ineffective (in case of external conditions which are not compatible with the safe operation of the equipment) the equipment switches off. In this case, if the temperature decreases, the power is raised again proportionally. If it decreases by 20°C the derating feature is exited and full power is restored. After 3 failed attempts, the control logic locks the equipment (alarm "011").

Thermal Management on Dummy Load

If the temperature measured in the vicinity of the Dummy Load exceeds 90°C, a first level of derating intervenes slightly in order to reduce the temperature through an output power reduction.

The power reduction is the lowest possible that allows a thermal balance to be reached at a temperature of less than 90 °C.

The output power reduction never exceeds 40% with this first derating. In other words, the output power is always 60% higher than that set by the user, and the "- 3 dB" signaling does not intervene.

This first derating level is effective in virtually all cases.

If the first level derating is insufficient (extremely rare), a second level intervenes, further reducing the power, thus obtaining a thermal balance status which is compatible with the safe operation of the equipment even if it is below - 3dB (with subsequent corresponding alarm).

If the second derating is ineffective (in case of external conditions which are not compatible with the safe operation of the equipment) the equipment switches off.

Thermal derating has a 10°C hysteresis before it attempts to restore the normal operating conditions of the equipment.

After 3 failed attempts, the control logic locks the equipment.

Current management on the power supply unit (Lifextender) ®

It is provided on amplifiers and exciters.

This is activated when the maximum current for continuous operation of the power supply is exceeded.

This value is set below the deliverable current limit and constitutes the threshold which can be exceeded only for short periods (maximum 1 minute at a time). If this situation arises, the "PSU current derating" function is activated (alarm "013" and/or "014" relative to amplifiers and modulators) and the ALC management algorithm, envisaged for normal operating conditions, is replaced by another one wherein the VDS control and Bias is determined by the power set and, with even higher priority, by the current delivered by the power supply.

The current derating condition is deactivated when the power delivered returns to the value set by the user and if the maximum current delivered by the power supply is less than or equal to the maximum value allowed for continuous operation.

Thermal management on the power supply unit (Lifextender) ®

It is provided on amplifiers and exciters.

The power supply management algorithm according to the temperature is the same as that on the RF unit, and it is logically connected in "OR" to the latter.

The first Derating level (acting directly on the output power) is activated when the power supply temperature exceeds 75°C, while the second level is activated - if the first is ineffective - if the temperature does not stabilize below this value.

In the latter case, the output power is brought below - 3 dB with the same procedure as that described for the RF section.

The activation of this feature is shown on the display as alarm "015" and /or"016" relative to amplifiers and modulators.

Fault management on RF modules (Lifextender) ®

It is provided on amplifiers and exciters.

This manages the maximum deliverable power according to the number of RF amplifier modules considered to be operating correctly.

If one or more MOSFETs are considered faulty (this happens when the absorbed current is 10% below the average value), the RF output power is reduced to the expected value when a fault occurs.

The failure case report and the relative maximum power achievable is described in a complex table obtained through tests. It is designed to stop failure propagation and prevent excessive stress on the MOSFETs that still work due to the ALC feature (which would require them to deliver all the missing output power).

In order to prevent a ridiculously high number of alarm SMSs, no messages are sent during this phase: the alarm SMS, if validated, is only sent after the adaptation procedure of the output power according to the table parameters and only if the -3dB condition occurs on the output power.

The activation of this feature is shown on the display as alarms "008" and "009" relative to amplifiers and modulators.

Cooling Management on the fan unit (Lifextender) ®

According to the actual cooling requirements, the rotation speed of the fans is adjusted from a minimum of 60% to a maximum of 120% approx. (these values may vary according to the models of fan used).

The cooling requirement is estimated based on the accurate temperature measurements which are performed in correspondence with the RF MOSFETs and the power supply unit in the case of amplifiers and modulators and on the Dummy Load.

The Cooling Management aims to extend the effective lifetime of the fans, minimize the quantity of dust that may be transported by the air flow and allow the safe operation of the equipment also under extreme temperature conditions.

Without the Lifextender the fans always work at 100%.

2.9.2 Hardware protections

The hardware protection system comprises:

- fast electronic and fuse protection of power supplies;
- fast electronic protection on the fan power supply;
- fast protection against excess reflected power (SWR/VSWR) following a strong load mismatch. This protection is activated when the reflected power value exceeds 10% of the forward power;
- protection against splitter and combiner overheating through fans with a thermostat;
- designed based on redundancy so as to eliminate the "SINGLE-POINT-FAILURE", that is any points which alone define an OFF-AIR situation;
- construction of metal parts in stainless steel and aluminium, treatment of the electronic boards with protective paint (tropicalization), closing off the most sensitive components to air flow with special shields in order to provide protection against corrosion.

2.10 Options

The equipment in this series can be purchased with different options included:

Version with modulating signal input	Purchase information: please request the following codes
MPX Inputs: <ul style="list-style-type: none"> • MPX • Aux 1 Outputs: <ul style="list-style-type: none"> • MPX monitor 	00T-6LLVVX-10 (ET30000-5 D.D.) 00T-6LLVOX-10 (ET30000-5 S.D.) 00T-5LLVVX-10 (ET25000-5 D.D.) 00T-5LLVOX-10 (ET25000-5 S.D.) 00T-4LLVVX-10 (ET20000-5 D.D.) 00T-4LLVOX-10 (ET20000-5 S.D.) 00T-3LLVVX-10 (ET15000-5 D.D.) 00T-3LLVOX-10 (ET15000-5 S.D.) 00T-2LLVVX-10 (ET10000-5 D.D.) 00T-2LLVOX-10 (ET10000-5 S.D.) 00T-XLLAAX-10 (ET5000 D.D.) 00T-XLLA0X-10 (ET5000 S.D.) 00T-XILAAAX-10 (ET3500 D.D.) 00T-XILA0AX-10 (ET3500 S.D.) 00T-XHLAAX-10 (ET3500 D.D.) 00T-XHLA0AX-10 (ET3500 S.D.)
STEREO Inputs: <ul style="list-style-type: none"> • Left channel • Right channel • MPX • Aux1 • Aux 2 Outputs: <ul style="list-style-type: none"> • MPX monitor/19 kHz 	00T-6LLVVA-10 (ET30000-5 D.D.) 00T-6LLVOA-10 (ET30000-5 S.D.) 00T-5LLVVA-10 (ET25000-5 D.D.) 00T-5LLVOA-10 (ET25000-5 S.D.) 00T-4LLVVA-10 (ET20000-5 D.D.) 00T-4LLVOA-10 (ET20000-5 S.D.) 00T-3LLVVA-10 (ET15000-5 D.D.) 00T-3LLVOA-10 (ET15000-5 S.D.) 00T-2LLVVA-10 (ET10000-5 D.D.) 00T-2LLVOA-10 (ET10000-5 S.D.) 00T-XLLAAA-10 (ET5000 D.D.) 00T-XLLA0A-10 (ET5000 S.D.) 00T-XILAAA-10 (ET3500 D.D.) 00T-XILA0A-10 (ET3500 S.D.) 00T-XHLAAA-10 (ET3500 D.D.) 00T-XHLA0A-10 (ET3500 S.D.)
AES/EBU Inputs: <ul style="list-style-type: none"> • Left channel • Right channel • MPX • Aux 1 • Aux 2 • AES-EBU Output: <ul style="list-style-type: none"> • MPX monitor/19 kHz 	00T-6LLVVD-10 (ET30000-5 D.D.) 00T-6LLVOD-10 (ET30000-5 S.D.) 00T-5LLVVD-10 (ET25000-5 D.D.) 00T-5LLVOD-10 (ET25000-5 S.D.) 00T-4LLVVD-10 (ET20000-5 D.D.) 00T-4LLVOD-10 (ET20000-5 S.D.) 00T-3LLVVD-10 (ET15000-5 D.D.) 00T-3LLVOD-10 (ET15000-5 S.D.) 00T-2LLVVD-10 (ET10000-5 D.D.) 00T-2LLVOD-10 (ET10000-5 S.D.) 00T-XLLAAD-10 (ET5000 D.D.) 00T-XLLA0D-10 (ET5000 S.D.) 00T-XILAAD-10 (ET3500 D.D.) 00T-XILA0D-10 (ET3500 S.D.) 00T-XHLAAD-10 (ET3500 D.D.) 00T-XHLA0D-10 (ET3500 S.D.)

The rack also may include:

- remote control unit (Echos3 or E.Box);
- surge arresters drawer;
- circuit breaker box positioned front or back (according to the type of model);
- cooling fan;
- technical panel and output connector positioned on the roof or rear (according to the type of model).

The LifExtender can be requested as an option using the previous codes. To be specified in the order.

3 Use instructions

3.1 User interface

3.1.1 Control unit user interface

The controls and display views of the control unit (representing the combined system interface as a whole) are described below.

Please note that in order to have complete visibility of all the available interfaces, **the equipment must be set to LOCAL mode** and it must be accessed with the specific passwords.

Specifically in REMOTE mode you lose visibility of the menus 485 SPEED SET, COM.ID LC/RT DISP MODE, TEMPERATURE UNIT, MAX REFLECTED POWER SWR FOLDBACK SETTING, NO MAINS AARM SETTING, UPS SETTINGS, GSM/MODEM menu.

Turn the encoder to navigate through the menu items.

To enter the desired item or to access a sub menu press the encoder while on the ">" icon.

To exit an item press the encoder while on the "<" icon.

If you change the value of a parameter, to maintain it, before turn off the machine wait at least 60seconds.

In the case of systems without control UNIT (ET5000, ET3500, ET2500) should be taken as reference the interfaces of the amplifier and the modulator.

Warning: the screen pictures shown below and the values attributed to the parameters are provided for illustrative purposes only. The parameters shown may vary slightly according to the equipment and setup type of the audio board.

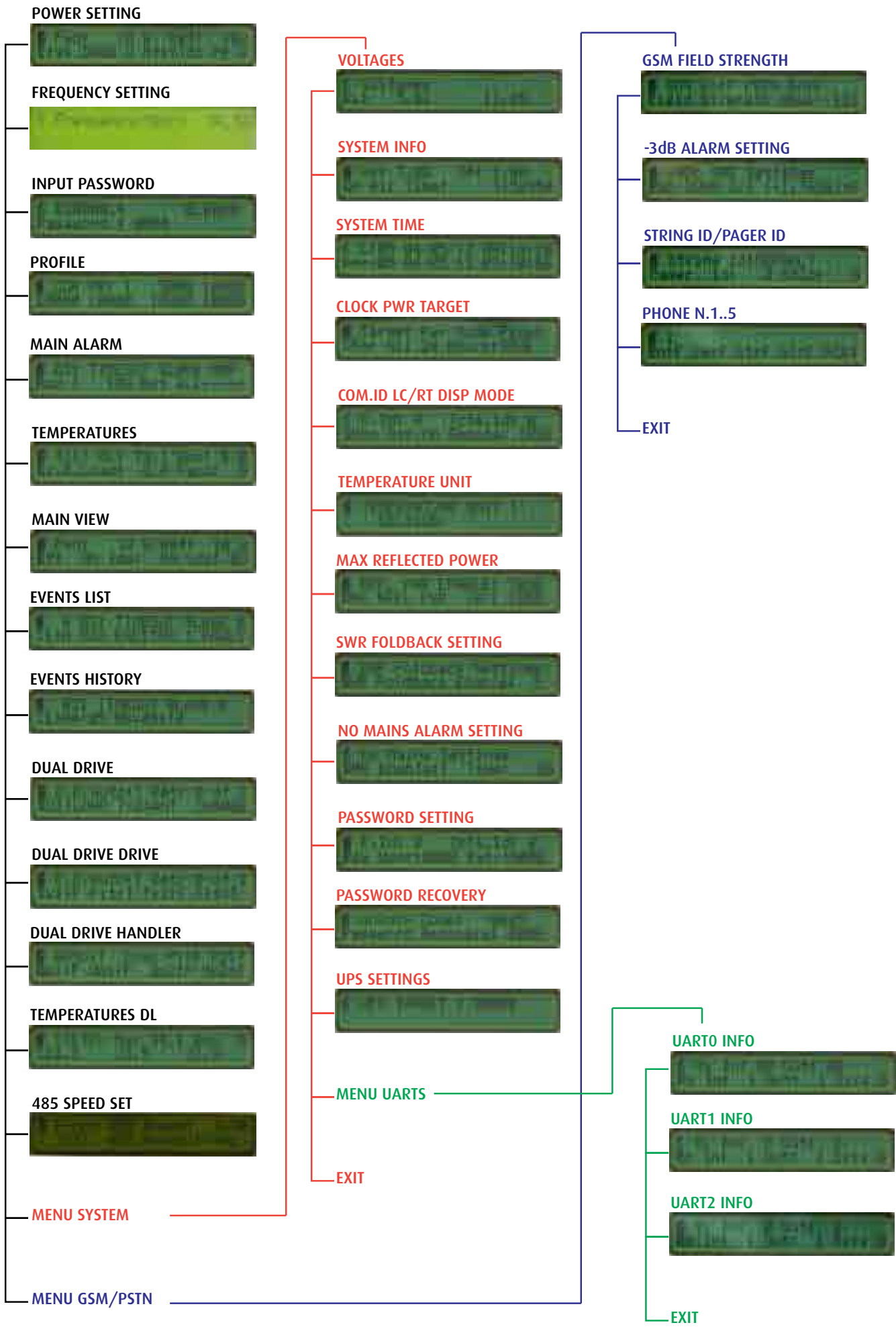

3.1.1.1 Power setting

Indication on the forward and reflected power.

Setting the desired target power, activating the transmission and enabling the profile.



3.1.1.2 Frequency setting

Setting the desired frequency.

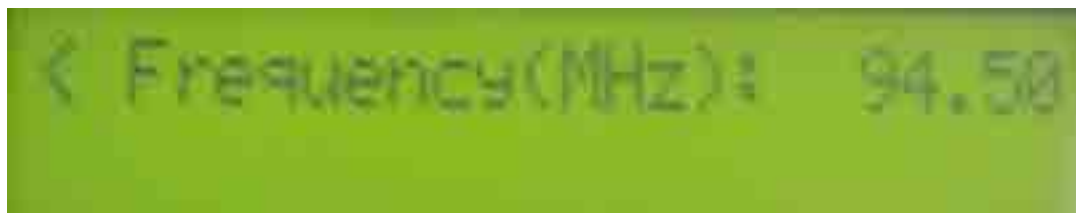

3.1.1.3 Input password

Some items are reserved and therefore can only be viewed and/or edited depending on the user authorisations. Here you can enter the access password.



3.1.1.4 Profile

Enabling the profile and displaying the power values of each profile.



3.1.1.5 Main alarm

Indication on the latest alarm occurred or on the correct operating condition. The forward power value is shown. Here the alarms can be reset.



3.1.1.6 Temperatures

Indication of the dummy load temperature, environment temperature, reserve exciter load temperature, fan speed.

The temperature indications depend on the presence of probes inside the equipment. Therefore, for certain types of equipment, some of these values may not be available.



3.1.1.7 Main view

Displaying the following parameters: forward power, reflected power, efficiency, current and voltage.



3.1.1.8 Events list

Alarm list. Those showing a letter "A" at the front are active. For further details, please see the "Alarms/events list" paragraph.



3.1.1.9 Events history

Indication of the date and time of each alarm.



3.1.1.10 Dual drive

Setting the exchange between the exciters in manual/automatic mode, as well as the maximum number of times for the exchange. Indication of which exciter is on the antenna and which is on the load. By selecting "CHANGE" here, it is possible to force the exchange.



3.1.1.11 Dual drive drive

Setting the exchange between the exciters in manual/automatic mode, as well as the maximum number of times for the exchange. Indication as to whether the exciters are "On Air" or not, and in alarm or not.



3.1.1.12 Dual drive handler

Setting the exchange between the exciters in manual/automatic mode, viewing the relay position, assigning the exciters to the antenna or the load.



3.1.1.13 Temperatures DL

Indication of the maximum temperature detected on the dummy load, the environment temperature, the individual temperatures detected on each load module. The temperature indications depend on the presence of probes inside the equipment. Thus, on certain types of equipment some of these values may not be available.



3.1.1.14 485 speed set

Setting the front and rear serial port 485 speed.



3.1.1.15 Voltages

Displaying the voltage values.



3.1.1.16 System info

Indication of the software version, the protocol version and the equipment activity time.



3.1.1.17 System time

Setting the day of the week, the date and the time.



3.1.1.18 Clock pwr target

As well as the standard power adjustment, it can also be set according to time slots in order to save energy.

For the power delivered to be set according to individual time slots, the option which makes it fixed for 24 hours must be deactivated.

To do so set "For All 24 Hours: FALSE".

The list of the time slots into which the whole day is divided is then displayed. Each time slot lasts one hour.

Go to the time slot for which you want to change the power, press the encoder to make it editable, set the new target power by turning the encoder, then press again to confirm.



3.1.1.19 Com. ID LC/RT disp. mode

Setting the addresses and activating the display so that the menus are also visible in REMOTE mode.



3.1.1.20 Temperature unit

Setting the temperature unit of measurement.



3.1.1.21 Max reflected power

The maximum reflected power permitted is 10% of the nominal power. Here it is possible to set a lower value when required by the user. Warning: in this case, correct operation of the foldback is not guaranteed.



3.1.1.22 SWR foldback setting

Foldback activation.



Algoritmo foldback

The Elenos devices feature two different and independent protections which are activated when there is excess reflected power.

The first is a hardware threshold which operates when the reflected power exceeds 10% of the maximum rated output power of the transmitter in a very short space of time.

In these conditions the transmitter switches off.

The second is a software protection, called "foldback algorithm".

It is activated when the reflected power increase is slower (for example, when there is snow or ice on the antenna).

In these conditions, the transmitter gradually reduces its output power until the reflected power threshold is exceeded, while the output power is gradually restored when the values go back to normal.

If normal operating conditions continue for more than 60 seconds, the algorithm is inactive.

The activation of this second protection is left to the user (from the SWR foldback setting screen).

3.1.1.23 No mains alarm setting

Setting the alarm, sent through an SMS, in the event of power failure for a set period of time.



3.1.1.24 Password setting

There are two levels of user privilege: USER and SYSTEM, which are both initially protected by the default password "0000".

In this screen it is possible to define customized passwords by the user with "SYSTEM" privileges.

Other parameters that can be set from this menu are the machine addresses (reference for communication with it).



3.1.1.25 Password recovery

If you lose your password, please contact Elenos.

Elenos must be given the "Unlock code" displayed on this screen.

Elenos will provide a password valid for 24 hours to be entered on the same screen under the "Password Recovery" item.

The user must later define new passwords through the "Password Setting" screen.



3.1.1.26 UPS settings

Setting the target power to be used when the machine is working with an uninterruptible power source.



3.1.1.27 Uart 0,1,2 info

Control menu for checking the serials.



3.1.1.28 GSM field strength

Indicating if the equipment is enabled to broadcast and receive SMSs, if it is in calling mode through the modem analog line.

The GSM coverage field is shown.

For further details, please see the "SMS list" paragraph.



3.1.1.29 -3dB alarm setting

Enabling the alarm -3dB to be sent by SMS.

This indicates that 2/3 of the power set has been exceeded.



3.1.1.30 String ID/Pager ID

Defining the workstation name and the codes to be viewed in the message strings.



3.1.1.31 Phone N.1 .. 5

Various SIM cards can "communicate" with the equipment (based on the customer requirements).

The telephone numbers in international format and authorizations can be set in these templates.

The number can be globally enabled for SMS transmission and reception (en), be enabled to send commands (cm), be enabled to request and receive the machine status (st), be enabled to receive the echo any of commands sent by other numbers (gl) and be enabled to receive SMSs in text or digital format (PC.)



3.1.2 Amplifier user interface

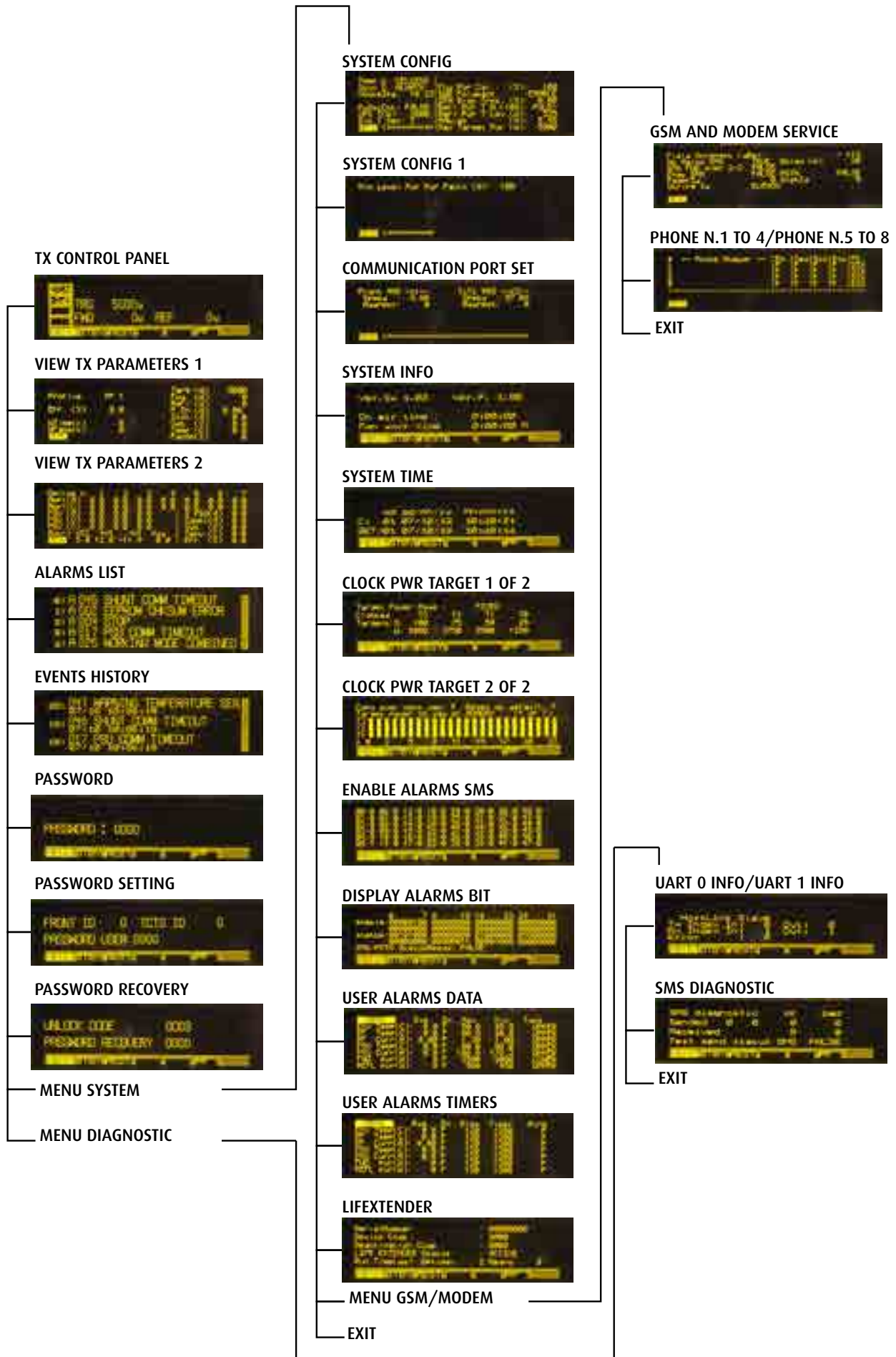

3.1.2.4 Alarms list

Display only screen.

It is possible to monitor the list of most recent alarms.

The alarms indicated by the letter "A" are still active.

In order to understand the meaning of the alarms, please refer to paragraph "Alarms/ events list".



3.1.2.5 Events history

Display only screen.

The log of all the events/alarms occurred (up to 99) can be monitored. These are indicated by code, description, date and time.



3.1.2.6 Password

The equipment is delivered with the default password "0000" that can be customized by the user (for more details, please see paragraph "Password Setting").

In this screen the access password must be entered.



3.1.2.7 Password setting

There are two levels of user privilege: USER and SYSTEM, which are both initially protected by the default password "0000".

In this screen it is possible to define customized passwords by the user with "SYSTEM" privileges.

Other parameters that can be set from this menu are the machine addresses (reference for communication with it).



3.1.2.8 Password recovery

If you lose your password, please contact Elenos. Elenos must be given the "Unlock code" in this screen. Elenos will provide a password valid for 24 hours to be entered on the same screen under the "Password Recovery" item. The user must later define new passwords through the "Password Setting" screen.



3.1.2.9 System config

Setting and display screen. The following parameters can be set by the user: temperature measurement unit (Temp. U.), remote display operating mode (Show D.), equipment protection in case of oscillations (PwOscChk), power target when working with a UPS (UPS T), minimum number of sensors on which to perform the check on the functionality resulting in sending alarm (Min T.Sen), power reading calibration (FwdPwrCal), SWR foldback, polarization threshold (IPA Bias Tres.), reflected power nominal threshold (Refl.Pwr T.N., when active it is 10% of direct power), reflected power customized threshold (Refl.Pwr T.Lev., when the nominal threshold is inactive, it is possible to set values below 10%), final polarization (PAbias), maximum settable power full scale (Max Target Pwr).



Power oscillation algorithm

In Elenos devices, if there is a power variation of "n" W ("n" being defined in specific tables) at least 3 consecutive times within 15 seconds, the "035" alarm is activated and the three block out mechanism is triggered (if this mechanism fails, the "003" alarm is then activated).

3.1.2.10 System config 1

Setting and display screen.

The alarm signal, caused by wrong output power, snaps by default at -3dB of target power and disappears when you reach the 2/3 of that.

The "Min Level Fwr Pwr Fault" additional parameter, set here, acts in an AND condition with the standard algorithm: so, the alarm will snap when there is the first between the two conditions "-3dB" and "Min Level Fwr Pwr Fault", while will disappear when the highest value between "2/3 Ptarget" and "Min Level Fwr Pwr Fault+typical step related to apparatus" occurs.

For stand-alone devices meant to set Min Level Fwr Pwr Fault to a value greater than -3dB, while using lower values may have meaning in N+1 systems.

By default Min Level Fwr Pwr Fault is set to the minimum value of power.



3.1.2.11 Communication port set

Setting and display screen.

The parameters which can be set by the user are the speed and the front and rear 485 door addresses.



3.1.2.12 System info

Setting and display screen.

The equipment software version, the protocol version, the equipment activity time and the fan operating time are indicated.

It is possible to reset the latter by clicking "R".



3.1.2.15 Enable alarms SMS

Setting and display screen.

Besides the alarm management "by status", it is possible to have alarm management "by event".

The alarms for which this management mode is enabled merge in a buffer.

If the value "0" is attributed to the relative alarm, it means that is deactivated, while the value "1" means that is activated to be managed in "by event" mode.

This function is available only by means of connection on the Omron protocol.

In order to understand the meaning of the alarms, please refer to paragraph "Alarms/ events list".



3.1.2.16 Display alarms bit

Setting and display screen.

Here is summarized the event configuration set in the menu "Enable Alarms SMS" (the "Enable") and those that are active are highlighted ("Status" field).

If the field "SMS / PSTN StatusReady" is "TRUE" means that an event is active, and has been sent alarm or phone call.

To return the field "FALSE" you need to reset alarms.



3.1.2.17 User alarms data

Setting and display screen.

Some alarms can be set according to activation conditions.

The current value of the alarm condition parameter (ambient temperature, RF temperature, RF current, power supply temperature, power supply current, direct power, reflected power) can be monitored.

By setting the "En." parameter to "T/F" the respective alarm is enabled/disabled.

The following parameters can be set by the user: the parameter minimum and maximum values, and the type of condition to be met (upper, lower, inside, outside).

	Reg.	En.	Max	Min	Type
ENV Temp(C):	0.0	F	50.0	45.0	UPPER
RF Temp(C):	0.0	F	90.0	98.0	UPPER
RF Curr(A):	0.00	F	1.20	1.00	UPPER
PSU Temp(C):	0.0	F	90.0	98.0	UPPER
PSU Curr(A):	0.0	F	198.0	178.2	UPPER
FWD Pwr(W):	0	F	2500	2000	LOWER
REFL Pwr(W):	0	F	500	450	UPPER

3.1.2.18 User alarms timers

Setting and display screen.

In some alarms, it is possible to set a time frame in which the condition must occur in order to make the alarm effective ("Delay").

The trend of the meter for this time can be monitored as well as the possible enabling of the alarm by means of a status flag (Alrm).

	Reg.	En.	Delay	Timer	Alrm
ENV Temp(C):	0.0	F	120	1200	F
RF Temp(C):	0.0	F	120	1200	F
RF Curr(A):	0.00	F	120	1200	F
PSU Temp(C):	0.0	F	120	1200	F
PSU Curr(A):	0.0	F	120	1200	F
FWD Pwr(W):	0	F	120	1200	F
REFL Pwr(W):	0	F	120	1200	F

3.1.2.19 Lifextender

Setting and display screen.

The parameters relative to the Lifextender option can be monitored: equipment serial number, equipment code (parameter to be notified to Elenos should the user require the activation/deactivation of this function), activation/deactivation code (parameter supplied by Elenos to be entered for the function activation/deactivation), function status, work days in good operating conditions, work days in critical operating conditions. The algorithm considers the following parameters to define the critical days: RF temperature, power supply temperature, ambient temperature and reflected power with respect to maximum operating power.

These parameters must exceed the threshold values for a certain amount of time.

In this way, the duration and intensity of the event is assessed: intense short events are heavy; less intense but longer events are heavy too.



3.1.2.20 GSM and modem service

Setting and display screen.

The GSM signal field intensity can be monitored.

It is possible to enable the submission of an alarm by SMS and/or PSTN in case of no mains power (No Mains SMS) for the period of time set (Delay).

It is possible to enable the submission of an alarm by SMS and/or PSTN if the power delivered is at least 3dB less than the target set (SMS FWD over 2/3).

The codes to be displayed in the different message strings can be defined (PagerId, StatId, String Id).



3.1.2.21 Phone N.1 to 4 / N.5 to 8

Setting and display screen.

The equipment can “communicate” with up to 8 SIM cards.

The telephone numbers and authorizations can be defined in international format

The number can be globally enabled for SMS transmission and reception SMS (En.), be enabled to send commands (Cmd), be enabled to request and receive the machine status (Sts), be enabled to receive the echo any of commands sent by other numbers (Glb) and be enabled to receive SMSs in text or digital format (PC.).



3.1.2.22 Uart 0,1 info

Control menu for testing the serial ports.



3.1.2.23 SMS Diagnostic

To see the number of SMS sent and received successfully.

For more detail see paragraph “SMS List”.



3.1.3 Exciter user interface

For further information, please consult the specific manual for the exciter.

3.2 Alarms/events list

There is an “Alarm management” module.

In order to check the alarm conditions, physical and logical digital inputs are used.

The status of each input is sampled and the condition is then logically processed by a combinational network so as to establish whether the alarm or signalling is active.

The minimum intervention time is 100ms.

This module is repeatedly performed with the same priority as ALC management, so as to constantly monitor the alarm cause onset and therefore to intervene within the required time frame.

A log stores the sequence of the last events generating alarms with the date and time of activation.

3.2.1 Control unit alarms/events list

Alarm/event	Description
“000 CORRECT WORKING”	This indicates correct equipment operation. The “On air” event has higher priority.
“001 SYSTEM RESET”	This indicates that the alarm reset is in progress. All stored and inactive alarms are removed from the list.
“002 EEPROM CHKSUM ERROR”	This indicates that the stored data is not reliable any longer and the machine is reconfigured according to the default parameters.
“003 BLOCKED”	This indicates that the machine is blocked after making 5 restore attempts. the user must reset in order to allow the equipment to restart.
“004 STOP”	This indicates that the equipment is in stand-by mode and is ready to start without alarms.
“005 -3dB CARRIER”	This indicates that the equipment has been delivering power at least 3dB less than the target set, for at least a minute in start-up and 5 seconds of normal operation.
“006 HIGH REF PWR”	This indicates that the level of reflected output power is too high, meaning that the equipment will turn off in three block out.
“007 RF THERMAL DERATING”	This indicates a too hot temperature on amplifiers, which implies a reduction in maximum power output.
“008 RF OVER TEMPERATURE”	This indicates a maximum operating temperature overcoming for RF amplifier stage, resulting in shutdown of the machine in three blocks out. This protection occurs in extreme cases where the mechanism Derating was not enough to return to normal temperature values.
“009 EXTERNAL INTERLOCK”	This indicates that interlock is active.
“010 ON AIR”	This indicates that the device is functioning properly and is being transmitted.
“011 POWER UP”	This indicates that is being inserted in the storage an alert regarding the restart of the device.
“012 POWER DOWN”	This indicates that is being inserted in the storage an alert regarding the shutdown of the equipment.
“013 EXCITER EXCHANGE”	This indicates that there was an exchange of the exciter.
“014 EXCITER SYNC COAX”	This indicates that an assessment of relay position was made.
“015 INCORRECT COAX WORK”	This indicates that there is a relay problem.
“016 ON LOCAL SLAVE AMPLIFIER”	This indicates that one or more amplifiers are in LOCAL mode.

"017 TIMEOUT SLAVE AMPLIFIER"	This indicates that one or more amplifiers have communication problem.
"018 EXCITER 1 FAULT"	This indicates that exciter 1 is fault.
"019 EXCITER 2 FAULT"	This indicates that exciter 2 is fault.
"020 UPS ACTIVE"	This indicates that UPS is active.
"021 SW INTERLOCK INCORRECT WORK"	This indicates an interlock signals hardware failure.
"022 EXCITERS FAULT"	This indicates that both exciters are fault.
"023 WORKING MODE COMBINED"	This indicates the machine operation in a combined system.
"024 USER ENV TEMP OUT LIMIT"	This indicates a deviation from the conditions to set by user in relation to environment temperature measured from the apparatus.
"025 USER RF TEMP OUT LIMIT"	This indicates a deviation from the conditions to set by user in relation to RF modules temperature.
"026 USER FRW PWR OUT LIMIT"	This indicates a deviation from the conditions to set by user in relation to forward power.
"027 USER RFL PWR OUT LIMIT"	This indicates a deviation from the conditions to set by user in relation to reflected power.
"028 NO AUDIO"	This indicates the absence of the audio signal.
"029 TIMEOUT SLAVE AMPLIFIER 1"	This indicates that amplifier n.1 have communication problem.
"030 TIMEOUT SLAVE AMPLIFIER 2"	This indicates that amplifier n.2 have communication problem.
"031 TIMEOUT SLAVE AMPLIFIER 3"	This indicates that amplifier n.3 have communication problem.
"032 TIMEOUT SLAVE AMPLIFIER 4"	This indicates that amplifier n.4 have communication problem.
"033 TIMEOUT SLAVE AMPLIFIER 5"	This indicates that amplifier n.5 have communication problem.
"034 TIMEOUT SLAVE AMPLIFIER 6"	This indicates that amplifier n.6 have communication problem.
"035 ETG 1 TIMEOUT/TYPE INCORRECT"	This indicates that exciter n.1 have communication problem/not used the correct driver.
"036 ETG 2 TIMEOUT/TYPE INCORRECT"	This indicates that exciter n.2 have communication problem/not used the correct driver.
"038 ON LOCAL ETG"	This indicates that the exciter is in LOCAL mode.
"040 SWR FOLDBACK"	This indicates that the machine is having a power reduction since the reflected power detected is too high.

3.2.2 Amplifier alarms/events list

Allarme/evento	Descrizione
"AMP_000 CORRECT WORKING"	This indicates correct equipment operation. The "On air" event has higher priority.
"AMP_001 SYSTEM RESET"	This indicates that the alarm reset is in progress. All stored and inactive alarms are removed from the list.
"AMP_002 EEPROM CHKSUM ERROR"	This indicates that the stored data is not reliable any longer and the machine is reconfigured according to the default parameters.
"AMP_003 BLOCKED"	This indicates that the machine is blocked after making 5 restore attempts. the user must reset in order to allow the equipment to restart.
"AMP_004 STOP"	This indicates that the equipment is in stand-by mode and is ready to start without alarms.

"AMP_005 -3dB CARRIER"	This indicates that the equipment has been delivering power at least 3dB less than the target set, for at least a minute in start-up and 5 seconds of normal operation.
"AMP_006 HIGH REF PWR"	This indicates that the level of reflected output power is too high, meaning that the equipment will turn off in three block out.
"AMP_007 MIN 12V"	This indicates that the negative voltage reference is altered and prevents correct operation of the protections. Stop in three block out.
"AMP_008 RF AMP. FAULT"	This indicates a fault on one or more RF .
"AMP_009 RF AMP. FAULT DERATING"	This indicates a fault on one or more RF modules, which implies a reduction in the overall maximum deliverable power.
"AMP_010 RF THERMAL DERATING"	This indicates an excessive temperature on the RF modules which implies a reduction in the maximum output power.
"AMP_011 RF OVER TEMPERATURE"	This indicates that the maximum operating temperature has been exceeded, thus causing machine turn off in three block out. This protection intervenes in extreme cases in which the Derating mechanism is not sufficient to make the temperature values go back to normal.
"AMP_012 PSU FAULT"	This indicates the malfunctioning of the power supply(ies).
"AMP_013 PSU CURRENT DERATING"	This indicates power supply overload which causes a decrease in the power delivered.
"AMP_014 PSU OVER CURRENT"	This indicates that the machine switches off if 1 minute after derating the current still does not decrease.
"AMP_015 PSU THERMAL DERATING"	This indicates power supply overheating which causes a decrease in the power delivered.
"AMP_016 PSU OVER TEMPERATURE"	This indicates power supply overheating which causes the equipment to switch off.
"AMP_017 PSU COMM TIMEOUT"	This indicates malfunctioning of the IEEE485 internal bus for communication between CPU, PSU and SHUNT.
"AMP_018 EXTERNAL INTERLOCK"	This indicates the presence of the active interlock.
"AMP_019 ON AIR"	This indicates that the device is working properly and is transmitting.
"AMP_020 POWER UP"	This indicates that the equipment restart signalling is being added to the log.
"AMP_021 POWER DOWN"	This indicates that the equipment switch off signalling is being added to the log.
"AMP_022 PSU THERMAL FAULT"	This indicates power supply overheating with subsequent switching off of the machine. For ELENOS equipment with more than one power supply, the intervention of this protection aims to allow operation at reduced power, should a power supply be disconnected to protect the hardware from excessive temperature.
"AMP_023 PSU LOW POWER"	This indicates a power drop with subsequent switching off of the equipment. For ELENOS equipment with more than one power supply, the intervention of this protection aims to allow operation at reduced power, should a power supply be disconnected to protect the hardware from a power decrease.
"AMP_024 PSU RF OFF"	This indicates a problem on 50V with subsequent switching off of the machine. For ELENOS equipment with more than one power supply, the intervention of this protection aims to allow operation at reduced power, should a power supply be disconnected to protect the hardware from the absence of RF power.
"AMP_025 WORKING MODE COMBINED"	This indicates the operation of the machine in a combined system.

"AMP_026 SWR FOLDBACK"	This indicates that the machine is having a power reduction since the reflected power detected is too high.
"AMP_030 OVER 2/3 CARRIER"	This indicates that 2/3 of the power set has been exceeded.
"AMP_031 PREAMPLIFIER NOT CONNECTED"	This indicates 100% reflected power. Not implemented here.
"AMP_032 OVER MODULATION"	This indicates over modulation.
"AMP_033 FAST INHIBIT"	This indicates that there are problems on the hardware lines leading to RF delivery inhibition.
"AMP_034 TEMPERATURE SENSOR ERROR"	Where there are multiple RF temperature probes, this indicates that one is faulty if it measures a noticeably different value from the other probes.
"AMP_035 PWR FORWARD OSCILLATION"	This indicates oscillations in the output power.
"AMP_036 THREE BLOCK OUT"	This indicates that restore procedure.
"AMP_037 USER ENV TEMP OUT LIMIT"	This indicates a variation with respect to the conditions set by the user relating to the ambient temperature measured by the equipment.
"AMP_038 USER RF TEMP OUT LIMIT"	This indicates a variation with respect to the conditions set by the user relating to the RF module temperature.
"AMP_039 USER PSU TEMP OUT LIMIT"	This indicates a variation with respect to the conditions set by the user relating to the power supply temperature.
"AMP_040 USER RF CURRENT OUT LIMIT"	This indicates a variation with respect to the conditions set by the user relating to the RF module currents.
"AMP_041 USER PSU CURRENT OUT LIMIT"	This indicates a variation with respect to the conditions set by the user relating to the power supply current.
"AMP_042 USER FRW PWR OUT LIMIT"	This indicates a variation with respect to the conditions set by the user relating to the direct power.
"AMP_043 USER RFL PWR OUT LIMIT"	This indicates a variation with respect to the conditions set by the user relating to the reflected power.
"AMP_044 OUT PWR NOT VERIFIED"	This indicates that the output power cannot be detected properly.
"AMP_045 UPS ACTIVE"	This indicates that the UPS is active, therefore the equipment is using the target power set for operation in this mode.
"AMP_046 SHUNT COMM TIMEOUT"	This indicates the communication timeout on the polarizer. It stops the operation of the apparatus.
"AMP_047 WARNING TEMPERATURE SENSOR"	This indicates a fault in the temperature probes.
"AMP_049 DRAIN VOLTAGE FEEDBACK ERROR"	This indicates the lack of control of Vds for causes such as power failures, wrong feeding, etc..
"AMP_050 OVER FRW PWR ERROR"	This indicates the presence of overshoot in power.
"AMP_051 PILOT PWR GOOD"	This indicates that the driving power is correct and the driver enabled.
"AMP_052 INCREASE PILOT PWR"	This indicates that the driving power is in the range below, but close to the range of proper operation, and the driver is enabled. It is necessary to a slight increase of the same.
"AMP_053 DECREASE PILOT PWR"	This indicates that the driving power is in the range top, but close to the range of proper operation, and the driver is enabled. It is necessary to a slight decrease of the same.
"AMP_058 RTC FAULT"	This indicates that there were 3 consecutive mismatches between date/time hardware and firmware, or the date is formatted incorrectly.

"AMP_059 RTC USER UPDATED"	This indicates a date updates.
"AMP_060 RTC AUTOMATIC RECOVERY"	This indicates that there is a misalignment of more than 5 seconds between the time / date hardware and firmware.

3.2.3 Exciter alarms/events list

For further information, please consult the specific manual for the exciter.

3.3 SMS list

3.3.1 SMS commands (submit)

It is possible to submit SMSs in order to perform the following commands:

Command	SMS text
Power setting to xxxxx	PWR xxxxx
Stand-by setting	STBY
Stand-by setting	OFF
On Air setting	ON
Status demand	STS
Reset demand	RES
Exciter 1 On air	EXC1
Exciter 2 On air	EXC2
The number that sends this SMS will be disabled upon receipt alarm/status	SMSNO
The "n" number will be disabled upon receipt alarm/status	SMSNO n
The "n" number will be enabled upon receipt alarm/status	SMSYES n

3.3.2 Status/alarm SMS (reception)

It is possible to receive status or alarm SMSs, for example composed in this way:

```
Exxxx ID xx  
SMS String  
+39xxxxxxxxxxx  
STBY  
No mains xx m  
xxx Messaggio di segnalazione  
FWD yyyyy W  
REFL yyyyy W  
UMB PWR yyyyy W  
TEMPMAX yyyyy F/C DUMMY LOAD  
TEMPENV yyyyy F/C  
Exc. x
```

```
Exxxx ID xx  
SMS String  
+39xxxxxxxxxxx  
-3dB Alarm  
No mains xx m  
xxx Messaggio di segnalazione  
FWD yyyyy W  
REFL yyyyy W  
UMB PWR yyyyy W  
TEMPMAX yyyyy F/C DUMMY LOAD  
TEMPENV yyyyy F/C  
Exc. x
```

```
Exxxx ID xx  
SMS String  
+39xxxxxxxxxxx  
Status  
No mains xx m  
xxx Messaggio di segnalazione  
FWD yyyyy W  
REFL yyyyy W  
UMB PWR yyyyy W  
TEMPMAX yyyyy F/C DUMMY LOAD  
TEMPENV yyyyy F/C  
Exc. x
```

Exxxx ID xx
SMS String
+39xxxxxxxxxxx
Command
No mains xx m
xxx Messaggio di segnalazione
FWD yyyyy W
REFL yyyyy W
UMB PWR yyyyy W
TEMPMAX yyyyy F/C DUMMY LOAD
TEMPENV yyyyy F/C
Exc. x

Exxxx ID xx
SMS String
+39xxxxxxxxxxx
RedPwr
No mains xx m
xxx Messaggio di segnalazione
FWD yyyyy W
REFL yyyyy W
UMB PWR yyyyy W
TEMPMAX yyyyy F/C DUMMY LOAD
TEMPENV yyyyy F/C
Exc. x

Exxxx ID xx
SMS String
+39xxxxxxxxxxx
Exc.Exchange
No mains xx m
xxx Messaggio di segnalazione
FWD yyyyy W
REFL yyyyy W
UMB PWR yyyyy W
TEMPMAX yyyyy F/C DUMMY LOAD
TEMPENV yyyyy F/C
Exc. x

Where :

Exxxx ID xx is the description of the apparatus with indication of the ID number
SMS String is a customizable string of 10 characters
+39xxxxxxxxxxx is the telephone number of origin of the last command
STBY indicates that the machine is in Standby (Off)
-3dB Alarm indicates that the machine is working below the -3dB
Status is the response to an SMS status command
Command is the confirmation to a command
RedPwr indicates that the machine is working in power limitation due to the UPS
Exc.Exchange indicates that there was an exchange between the exciters (Dual Drivers)
No mains xx m indicates that the machine has been off for the indicated time (in minutes)
xxx Messaggio di segnalazione indicates a cause of arrest or a major signaling
FWD yyyyy W indicates the forward power
REFL yyyyy W indicates the reflected power
UMB PWR yyyyy W indicates the power imbalance
TEMPMAX yyyyy F/C DUMMY LOAD indicates the temperature of the load
TEMPENV yyyyy F/C indicates the environment temperature
Exc. x indicates the exciters state (EXC.1, EXC.2, EXC.FAULT)

Please note: The functionality of the SMS reception is interrupted for an hour, if they are sent by the system more than 5 messages over 5 min.

3.4 Externally connectable optional equipment

The equipment can be connected externally to the following units:

- PC
- Telemetry
- Exchange and/or Audio matrix
- Elenos E.BOX. module

3.4.1 Connection to PC

This connection is useful to analyse the equipment operating parameters in detail, for example during the performance assessment stage or during repairs.

To PC connection an interface must be inserted into the “Interface” connector, DB9, on the front panel of amplifiers and combiner; and add an other cable (ELENOS code **CAB0068-0**) to insert to PC.

This may be supplied with the product.

The connection can also be made when the machine is operating.

The Windows Hyperterminal programme can be used to display, or another equivalent available programme.

For the detailed procedure for using an ASCII terminal, please request technical bulletin No. 127 from the manufacturer.

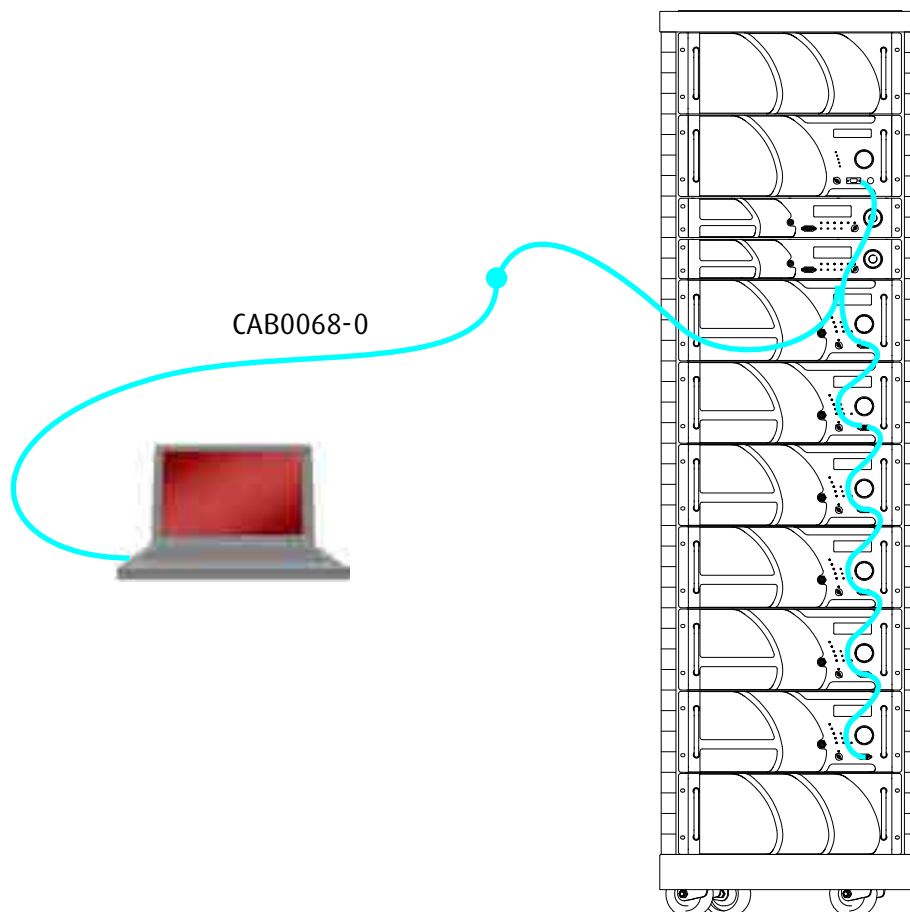

3.4.1.1 Control unit hyperterminal interface

The Hyperterminal pages have a very similar structure to the display view, hence they will not be further described herein.

Since there is more available space, there could be additional parameters.

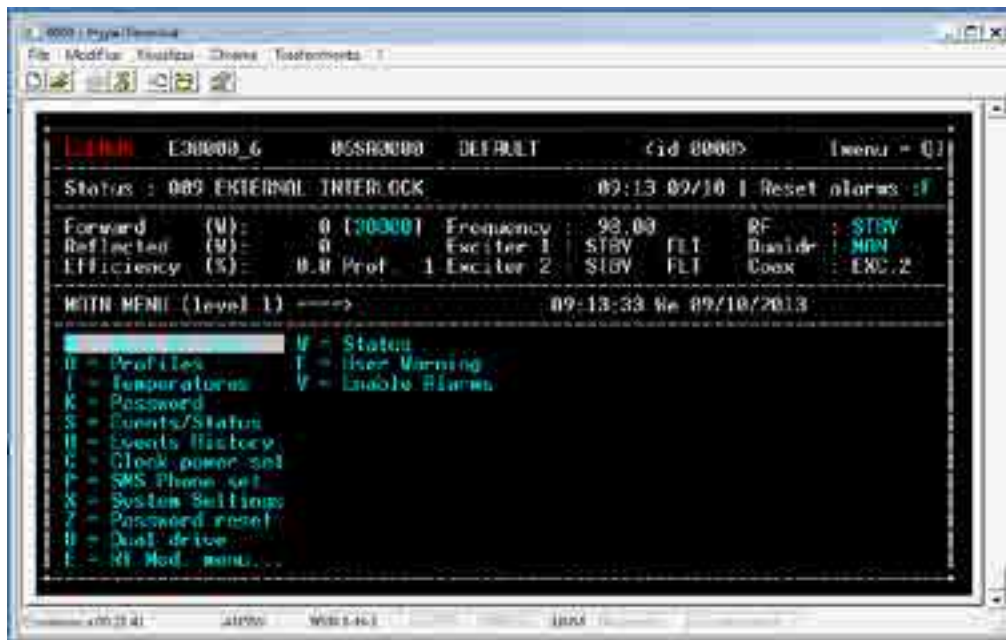

Main Menu

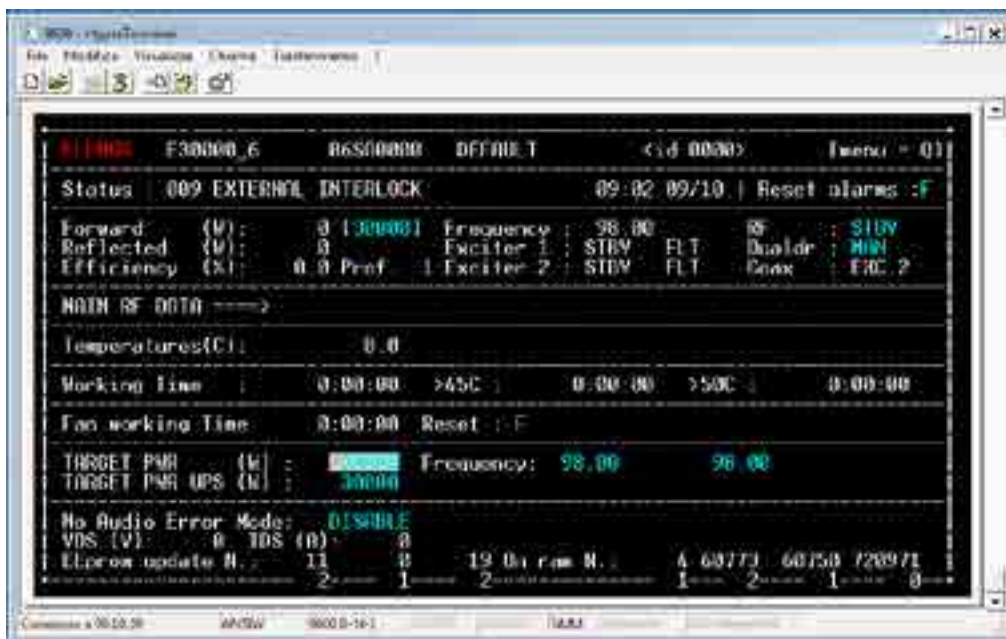

*Main Menu
Main RF Data (M)*

**Main Menü
Profiles (O)**

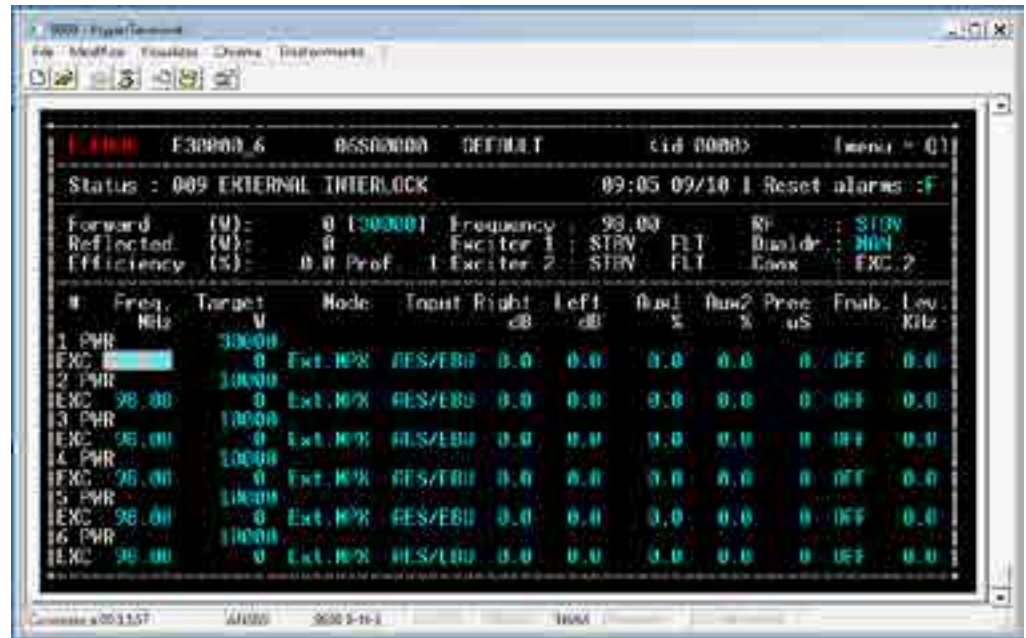

**Main Menü
Temperatures (T)**

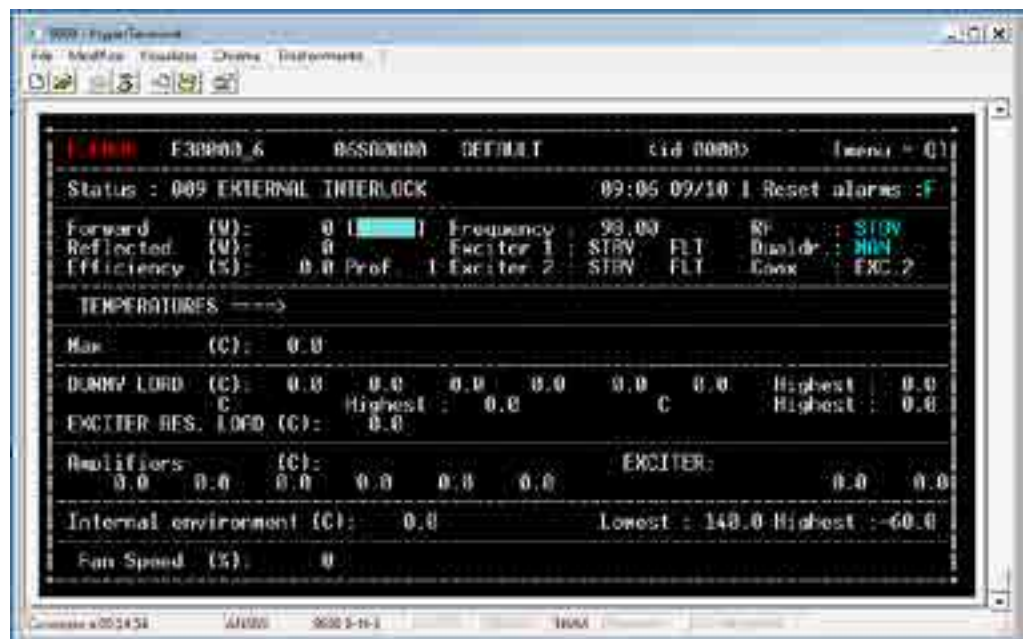

**Main Menü
Password (K)**

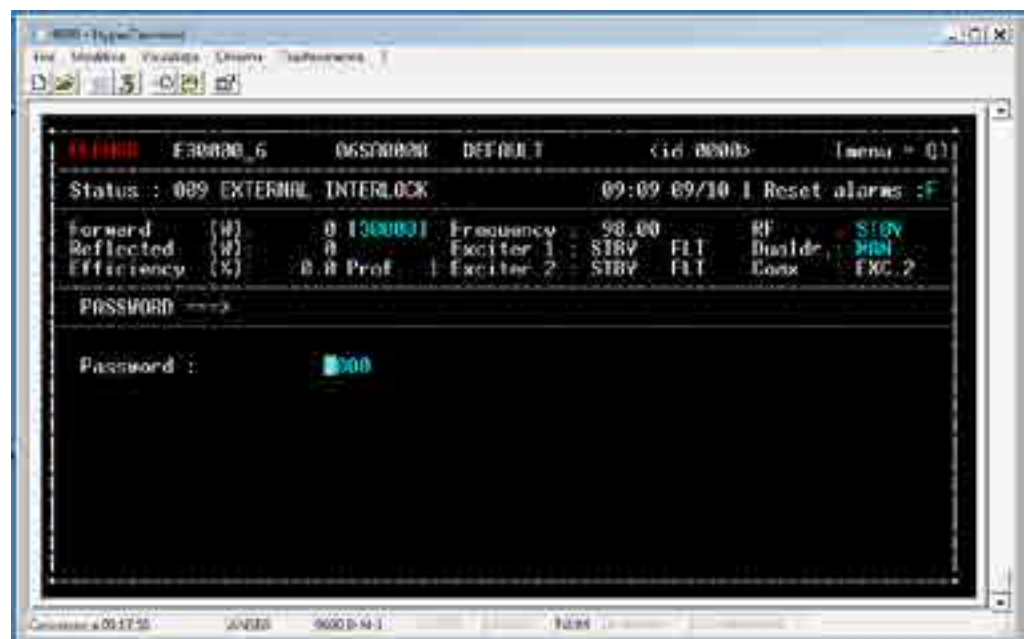

Main Menü
Events/Status (S)

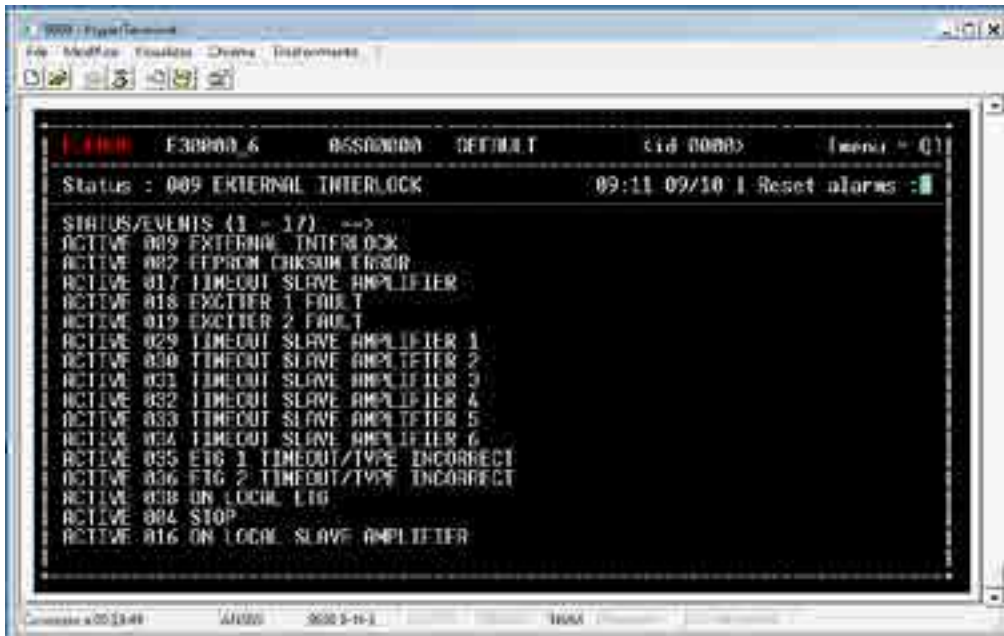

Main Menü
Events History (H)

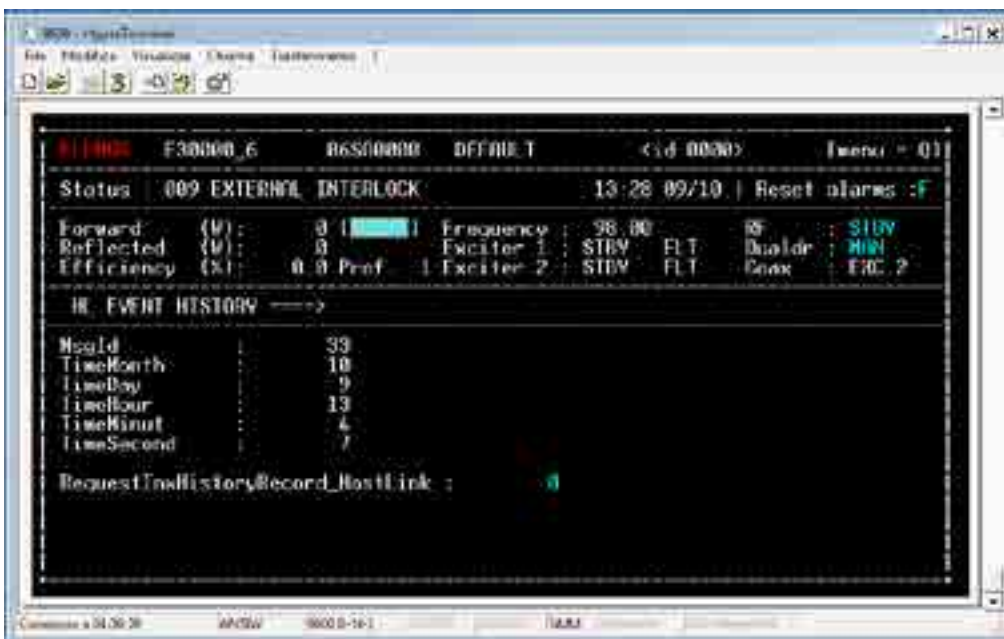

Main Menü
Clock Power Set (C)

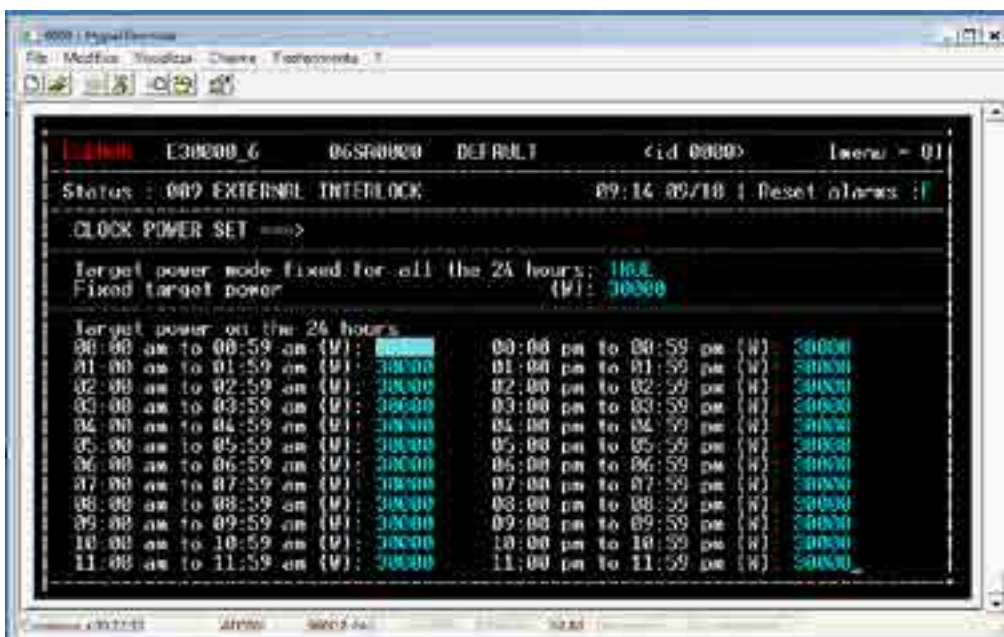

Main Menü
SMS Phone Set (P)

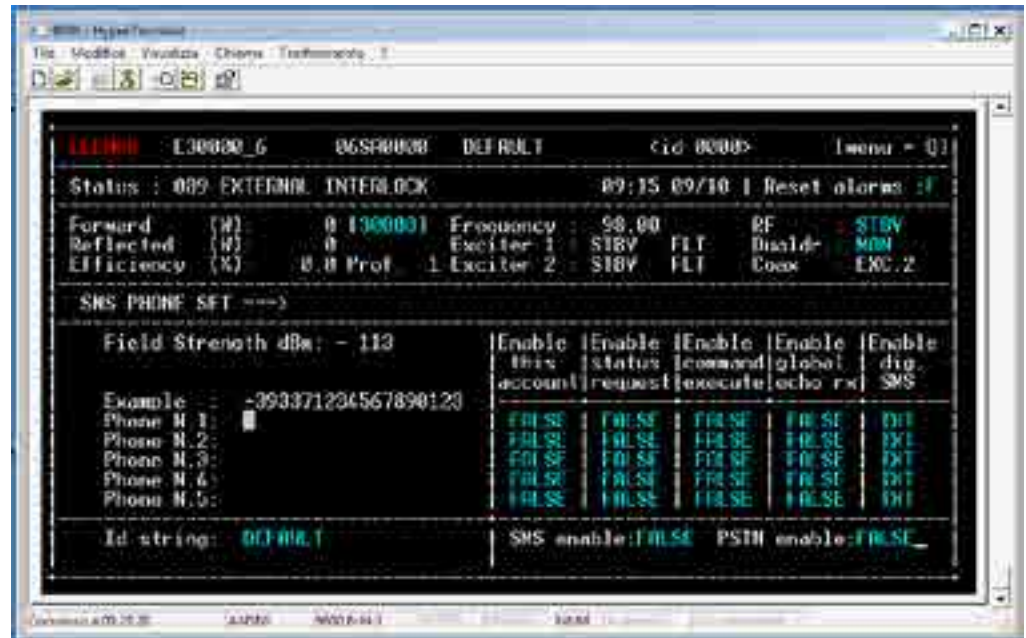

Main Menü
System Settings (X)

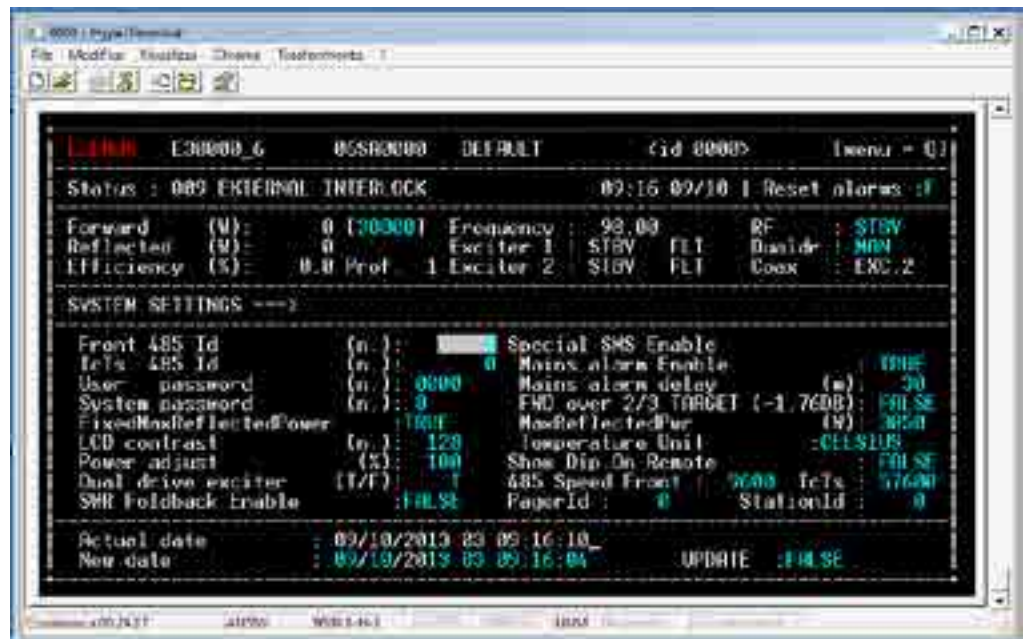

Main Menü
Password Reset (Z)

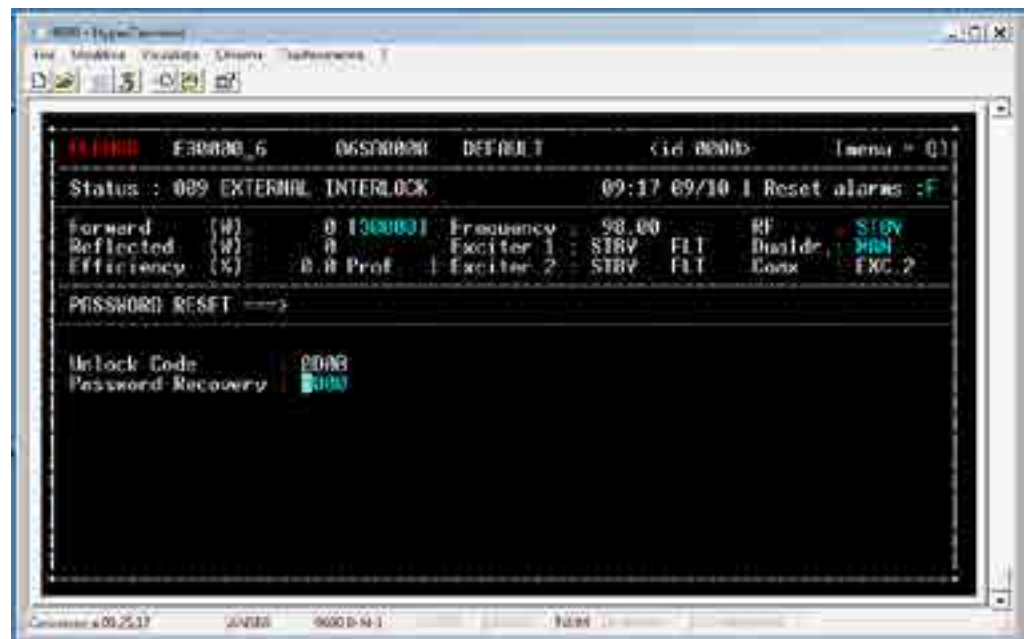

Main Menü
Dual Drive (D)

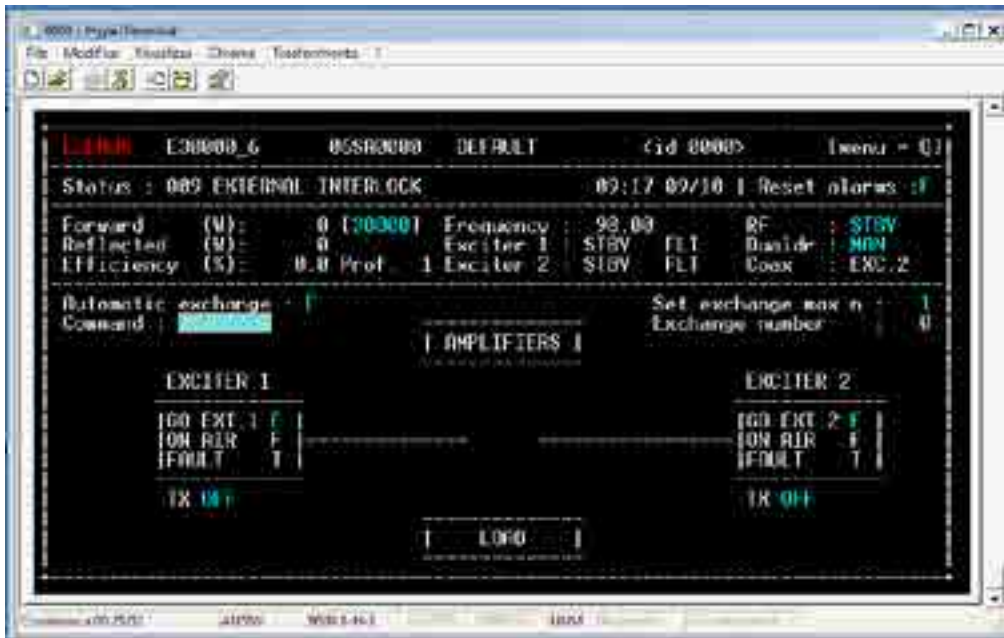

Main Menü
RF Mode Menü (E)

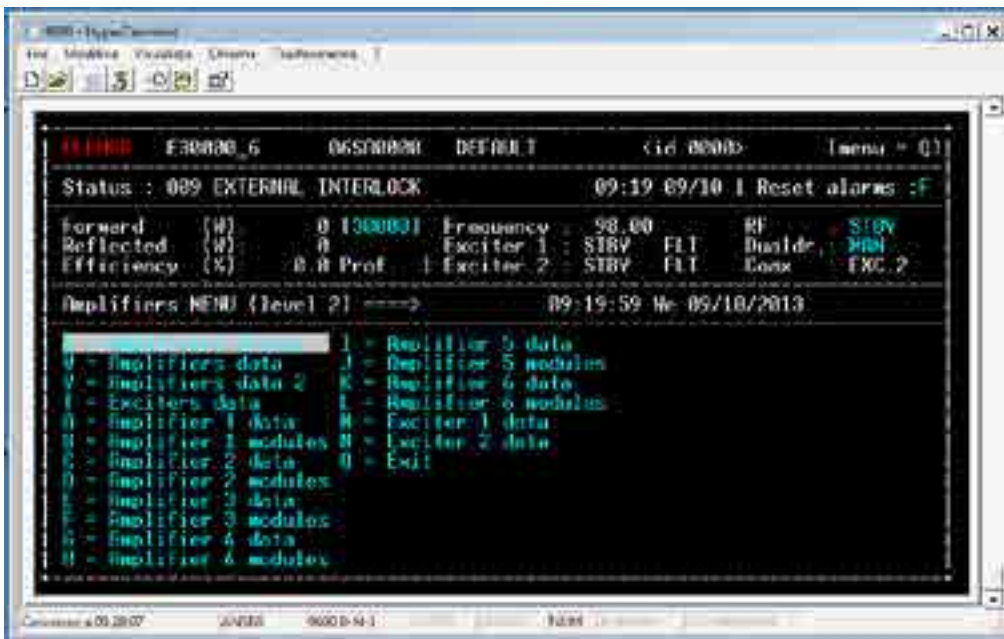

Main Menü
RF Mode Menü (E)
Amplifiers Status (S)

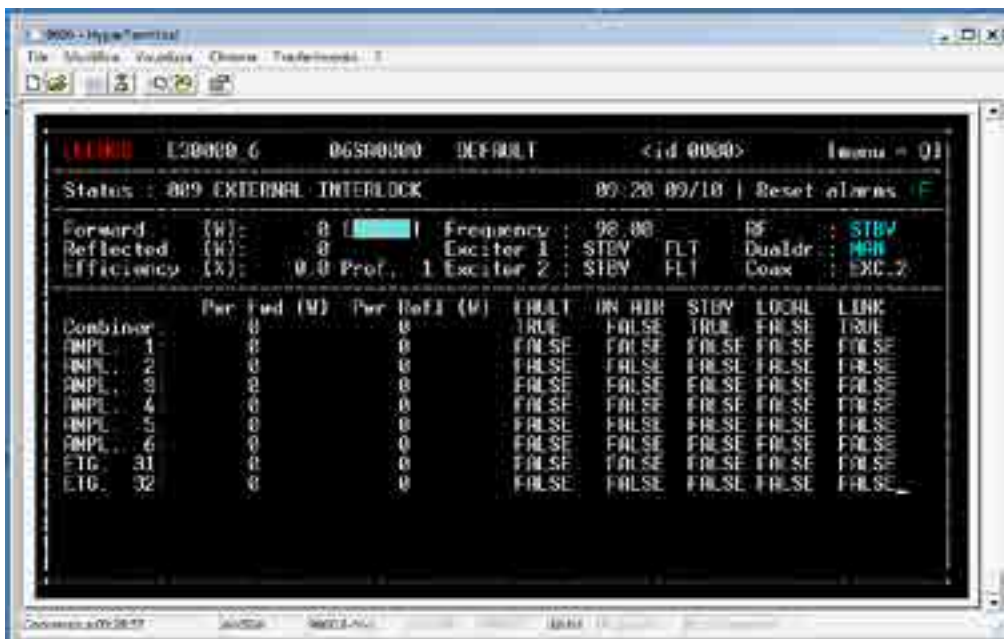

Main Menü
 RF Mode Menü (E)
 Amplifiers Data (W)

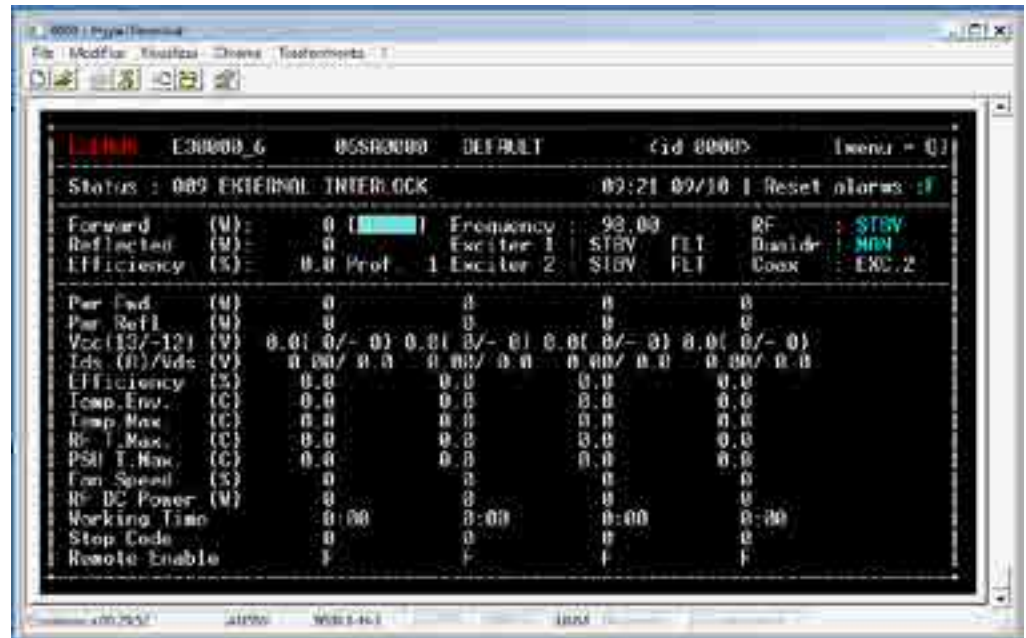

Main Menü
 RF Mode Menü (E)
 Amplifiers Data 2 (V)

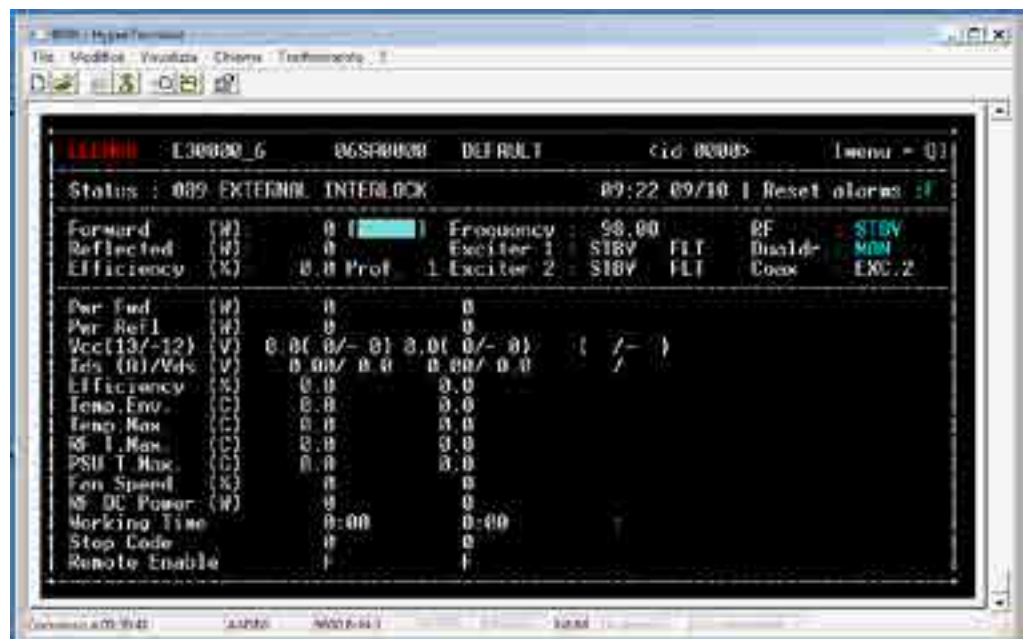

Main Menü
 RF Mode Menü (E)
 Exciters Data (T)

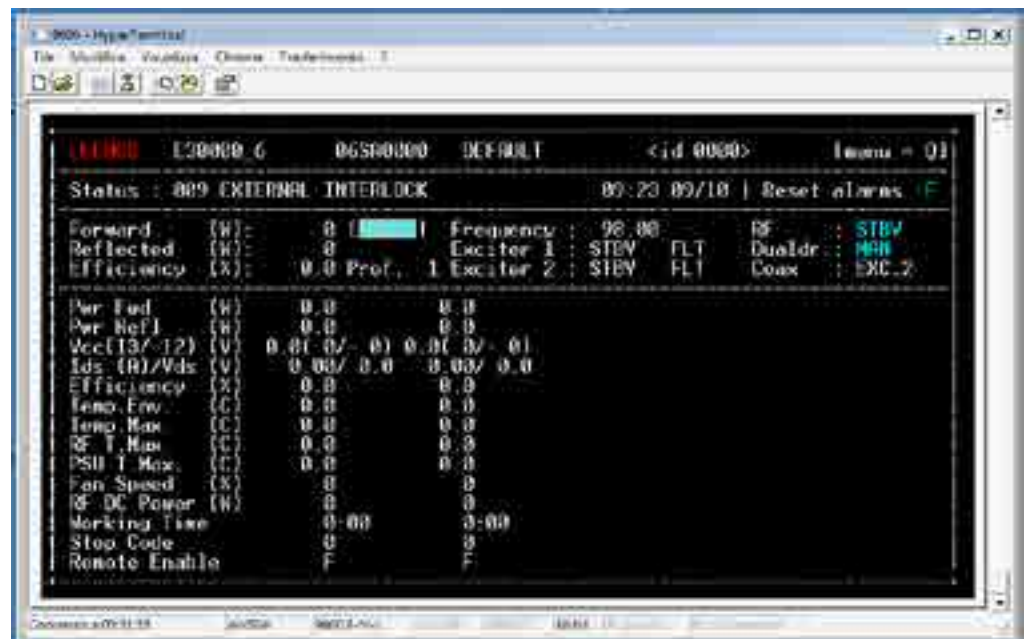

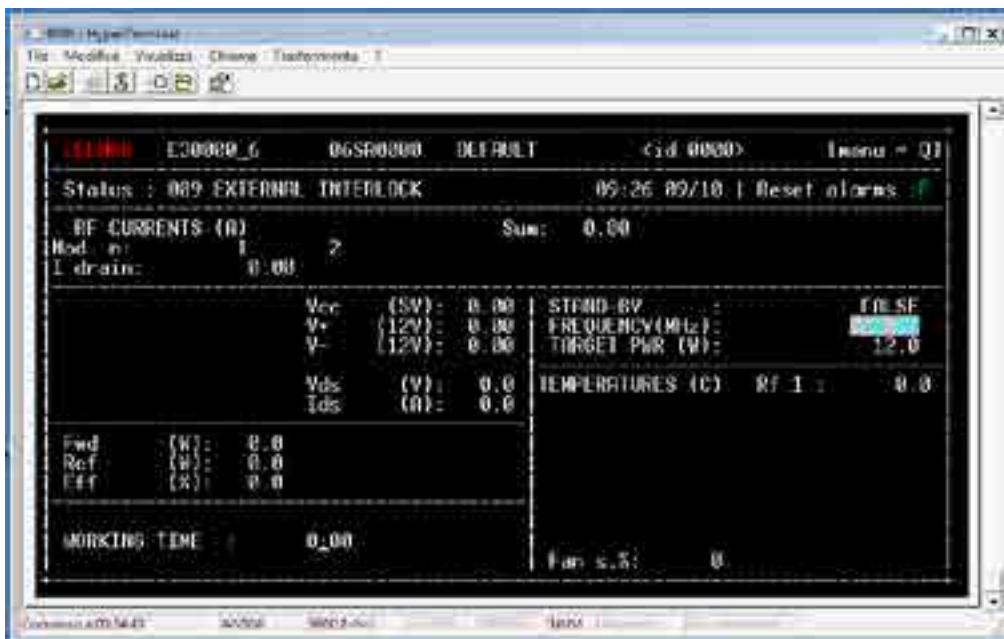
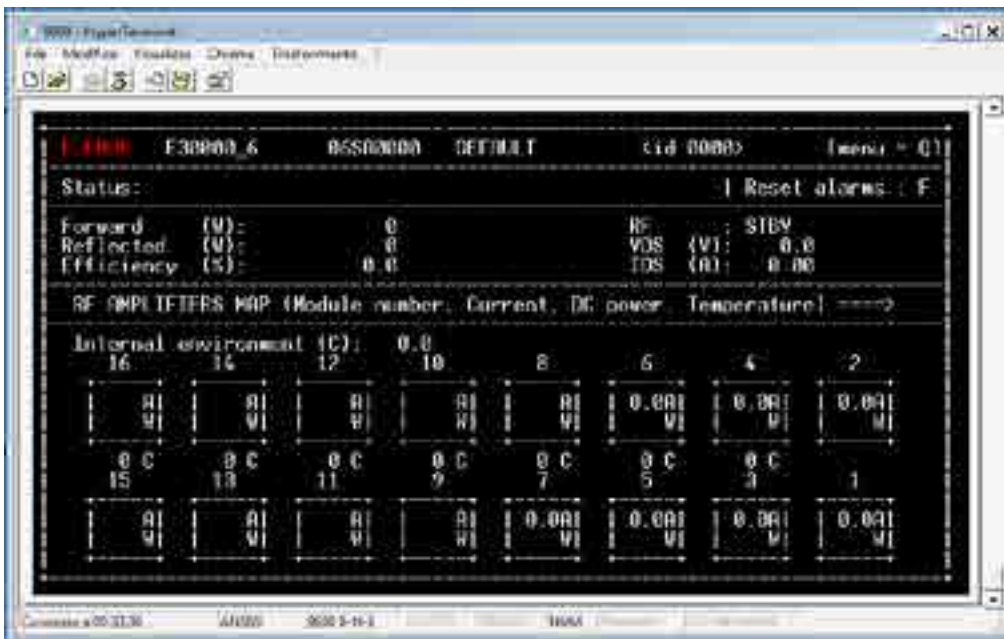
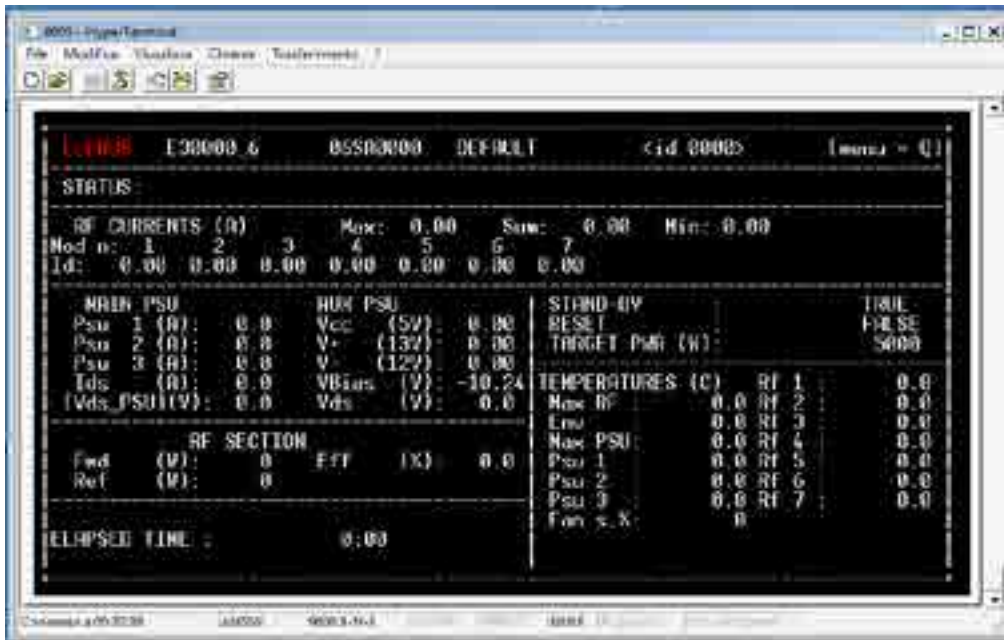

3.4.1.2 Amplifier hyperterminal interface

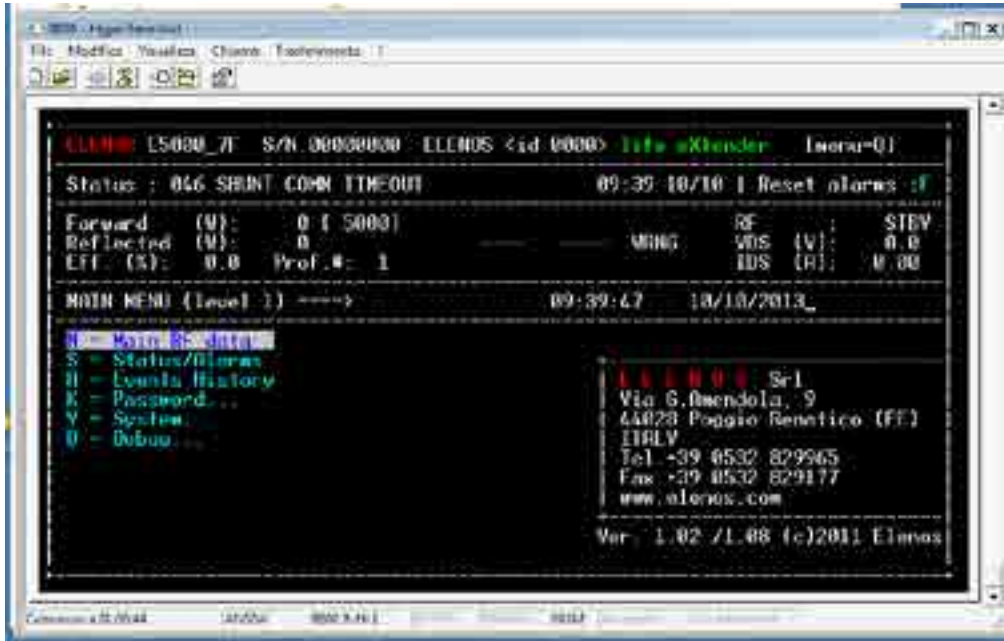

Main Menu



Main Menu
Main RF Data (M)

**Main Menü
Status/Alarms (S)**

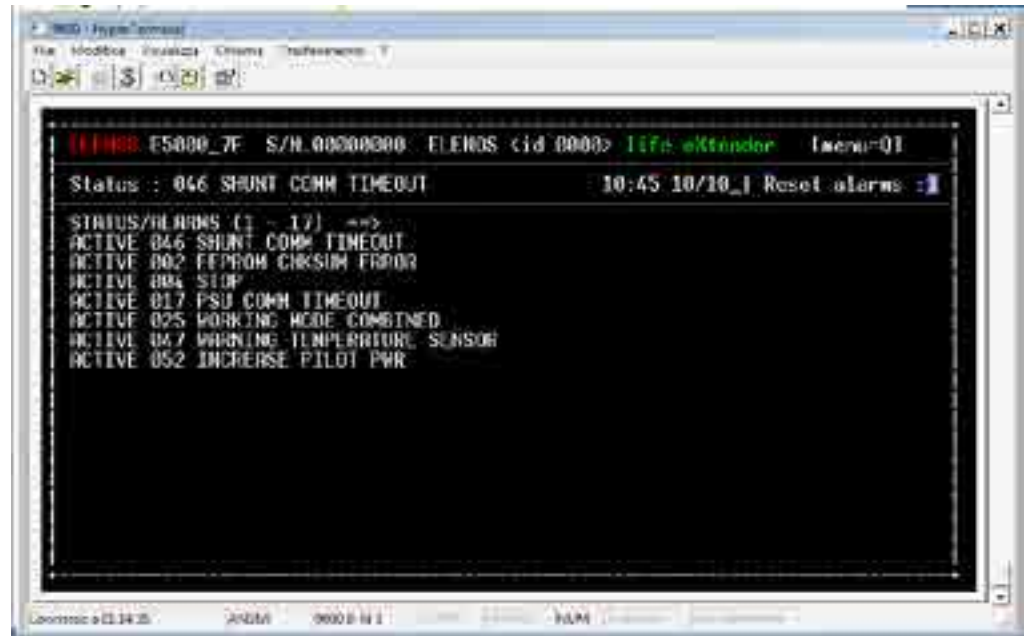

**Main Menü
Events History (H)**

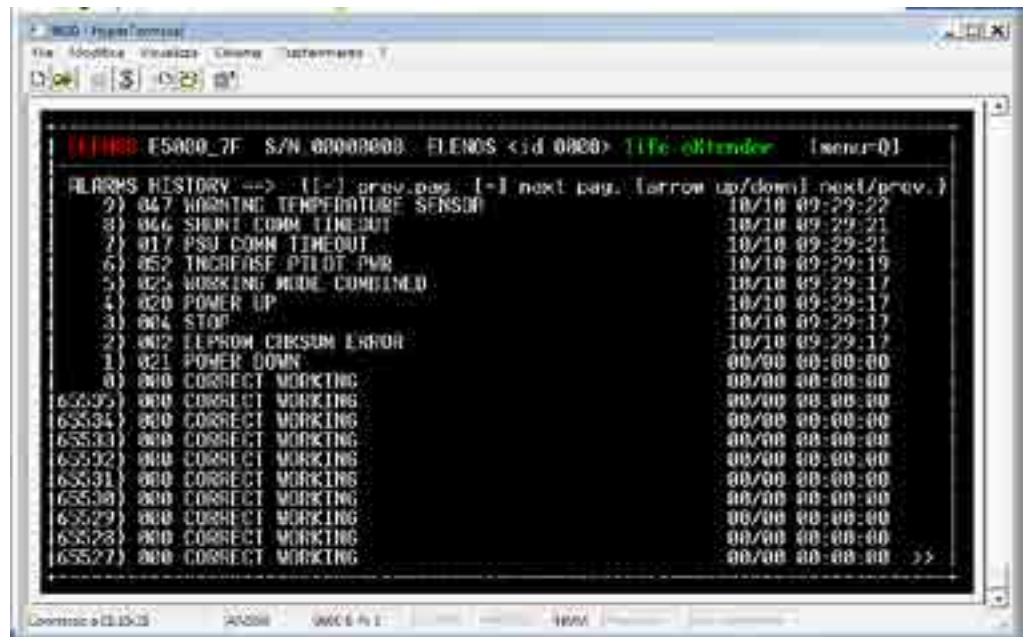

**Main Menü
Password (K)**

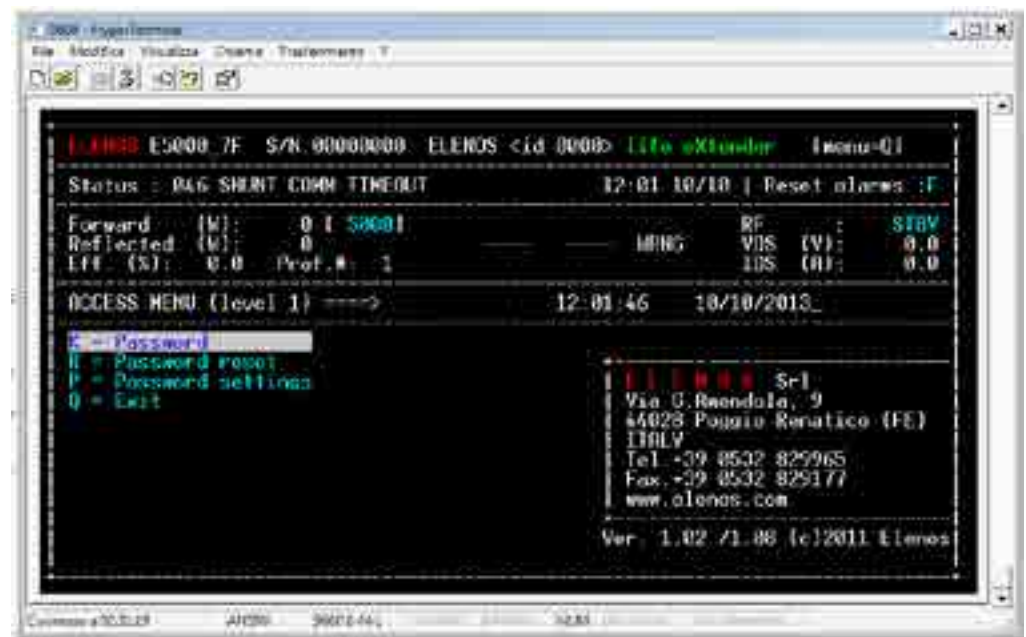



Main Menü
 Password (K)
 Password (K)

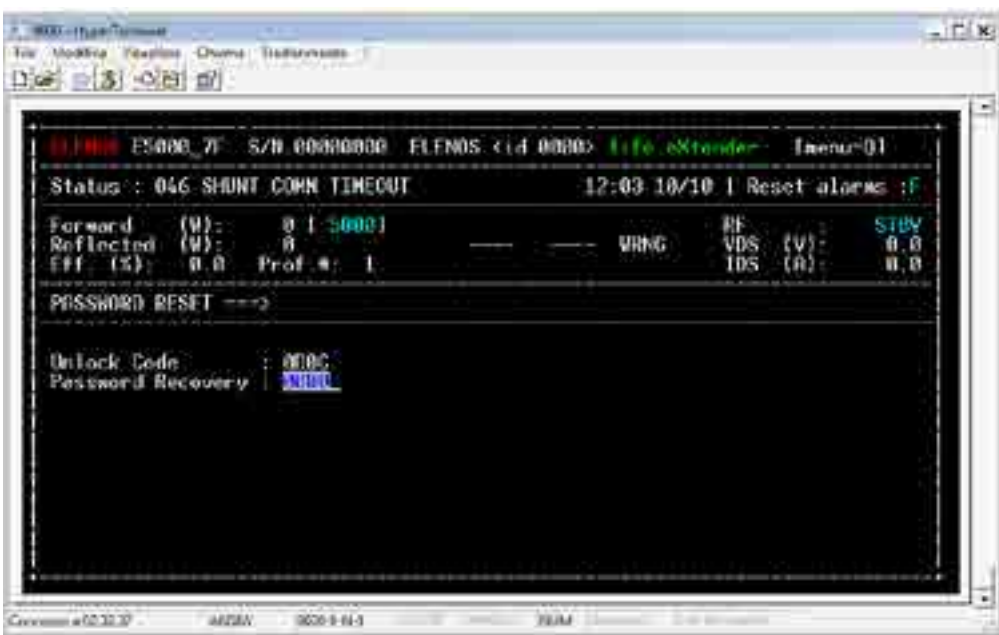

Main Menü
 Password (K)
 Password reset (R)



Main Menü
 Password (K)
 Password settings (P)

Main Menü
System (Y)

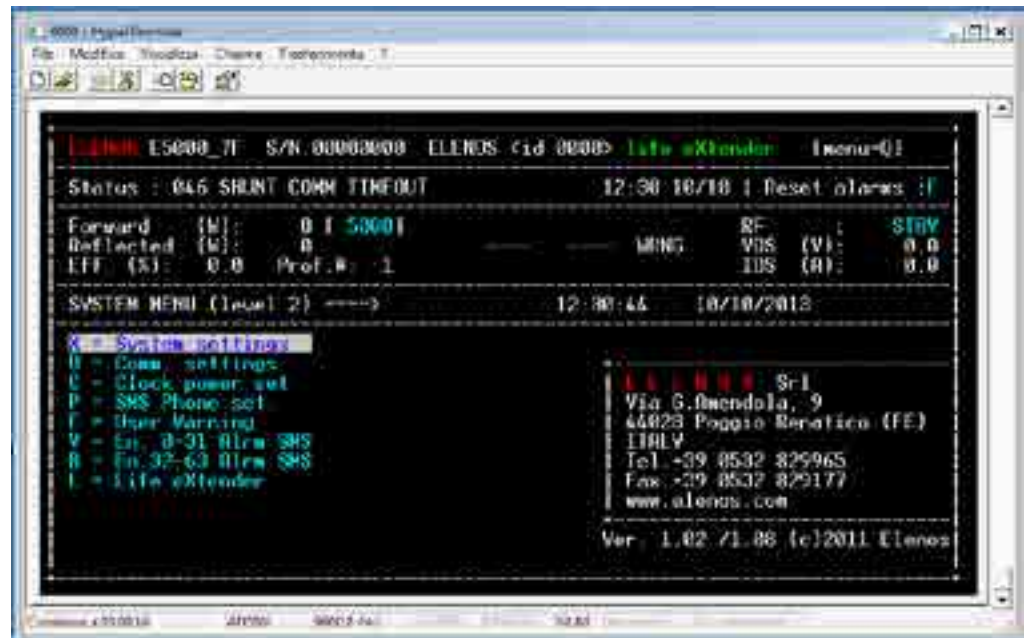

Main Menü
System (Y)
System settings (X)



Main Menü
System (Y)
Clock power set (C)

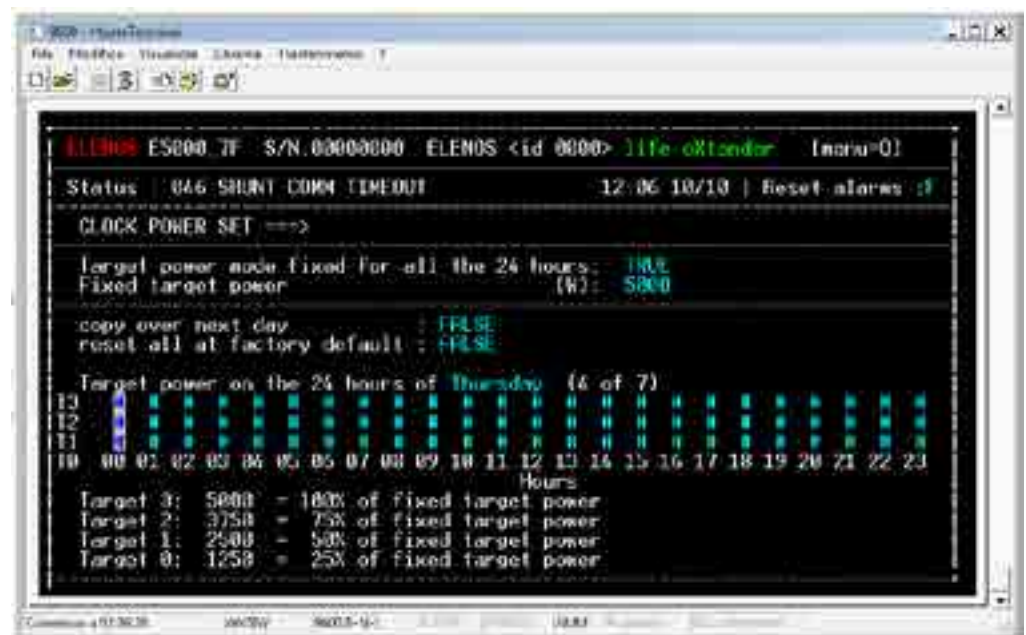

Main Menü
System (Y)
SMS phone set (P)

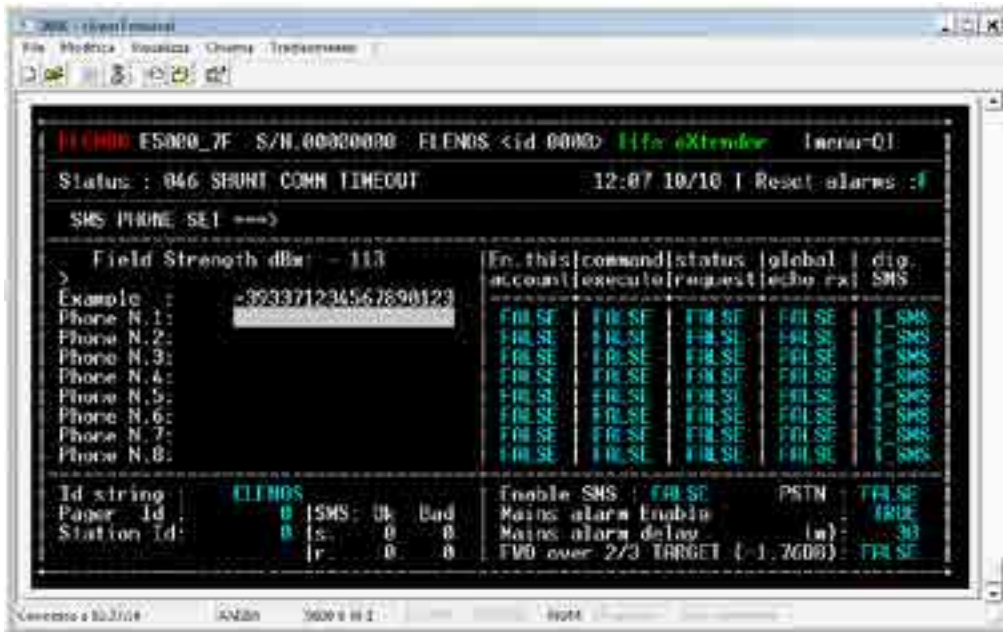

Main Menü
System (Y)
User warning (F)

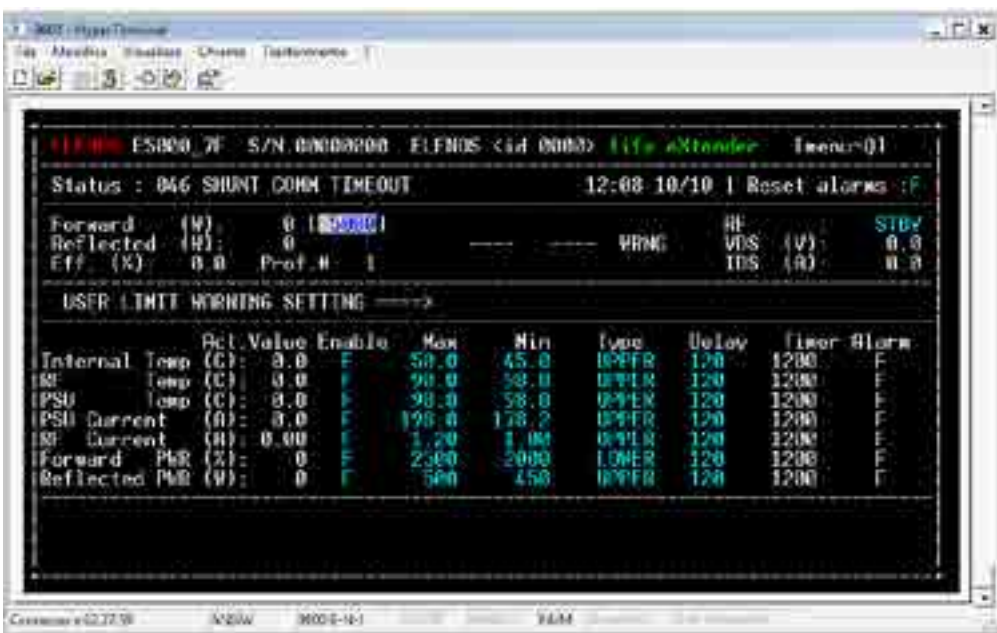

Main Menü
System (Y)
En. 0-31 alrm SMS (V)

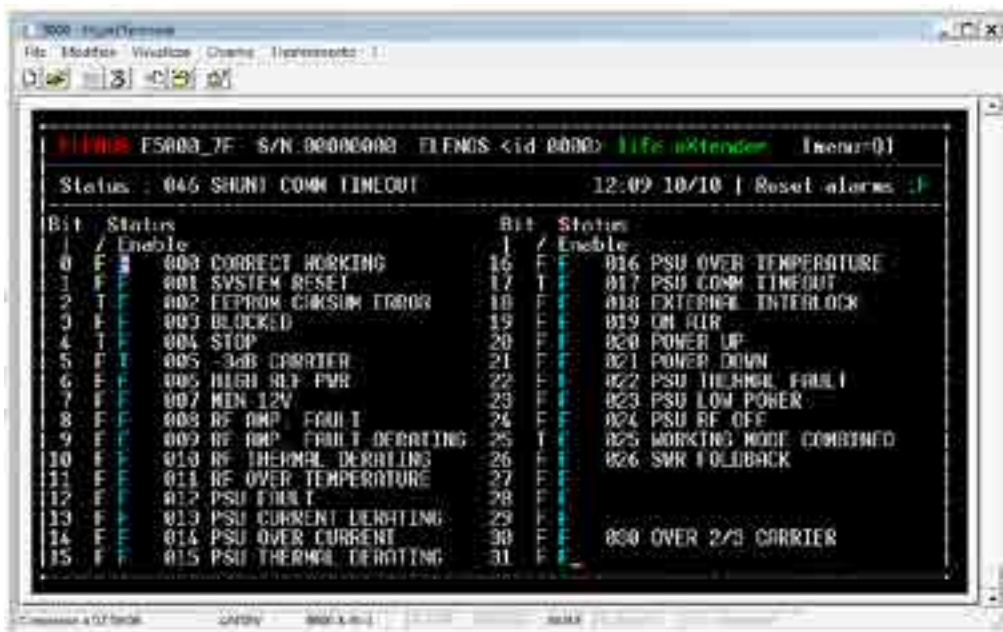

Main Menü
System (Y)
En. 32-63 alrm SMS (B)

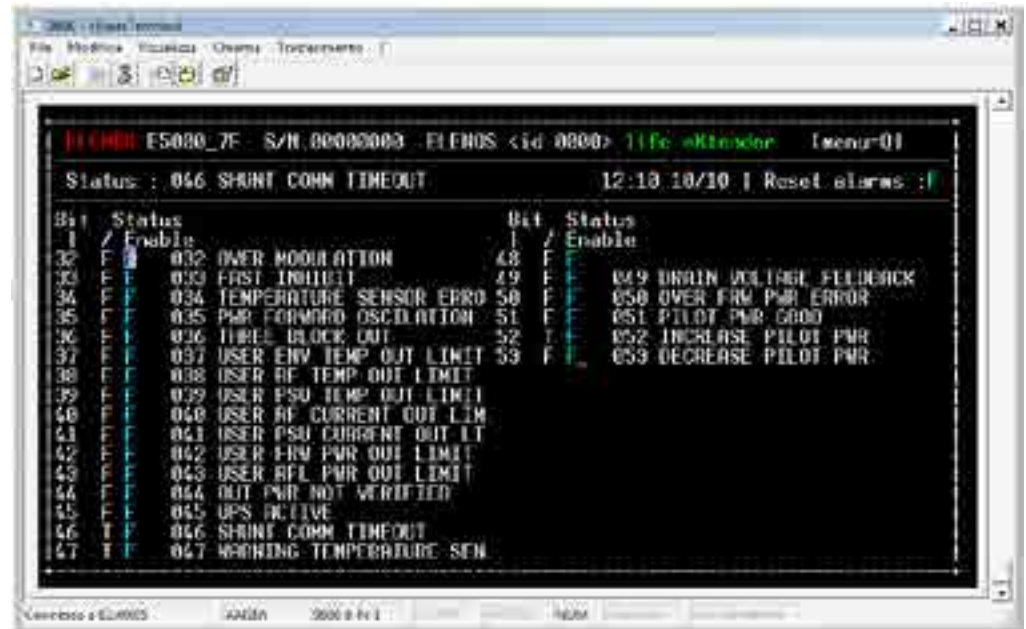

Main Menü
System (Y)
Lifextender (L)

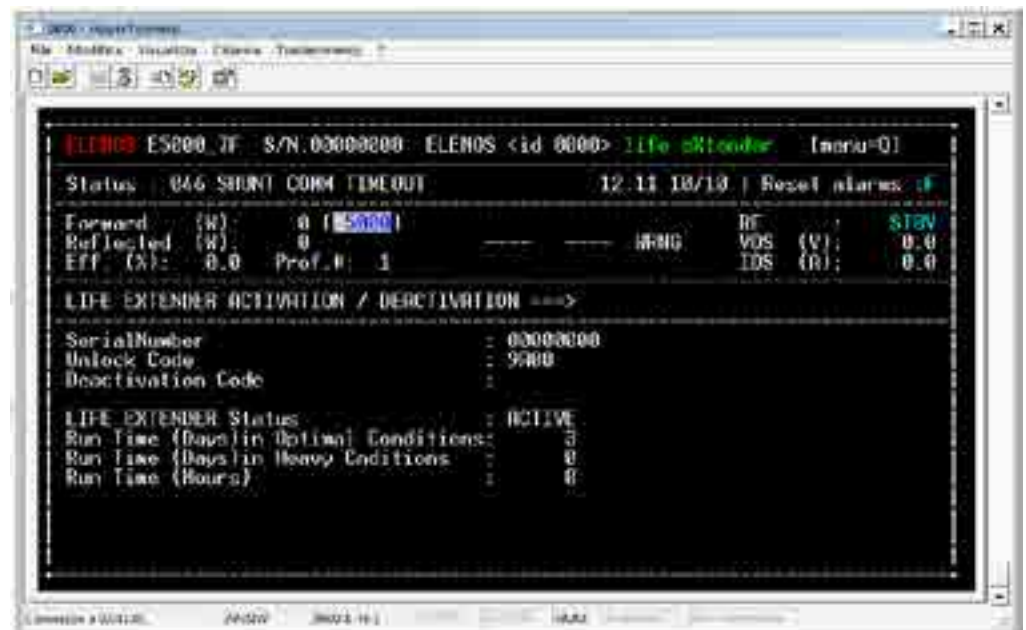

Main Menü
Debug (D)

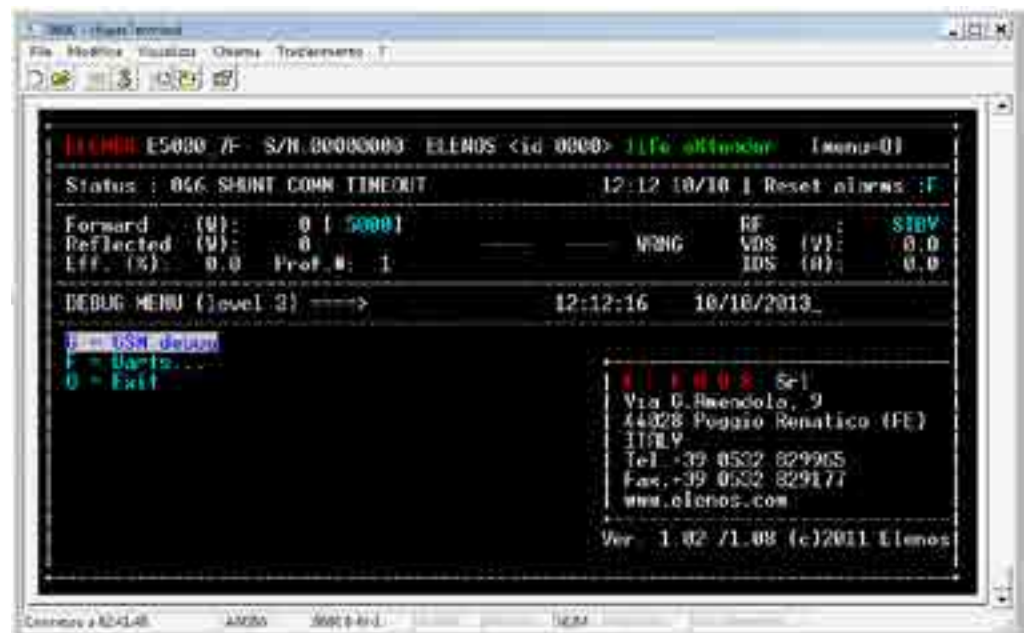

Main Menu
 Debug (D)
 GSM debug (G)

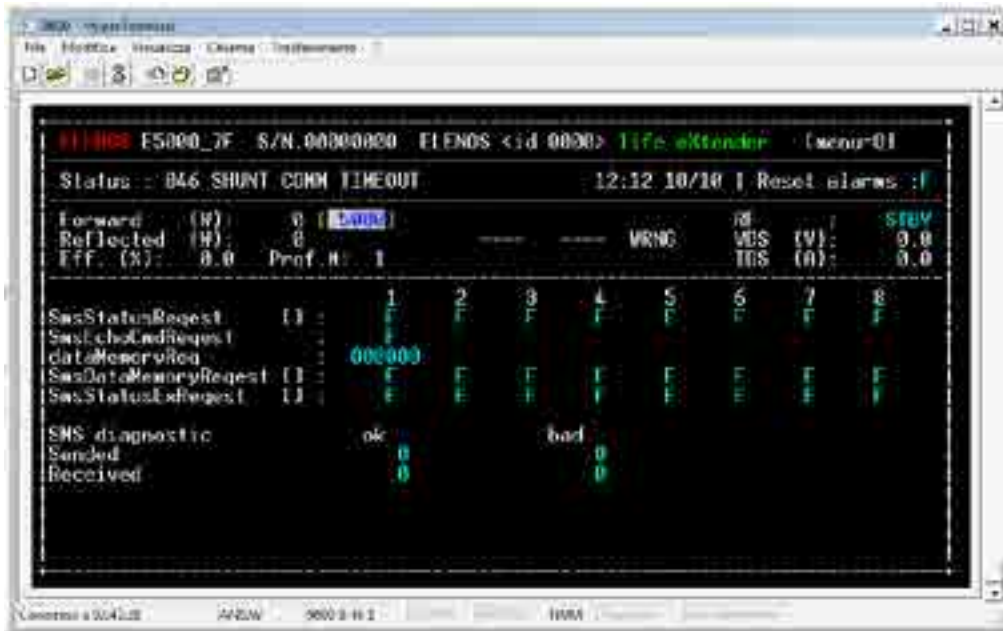

Main Menu
 Debug (D)
 Uarts (F)



Main Menu
 Debug (D)
 Uarts (F)
 Uart 0

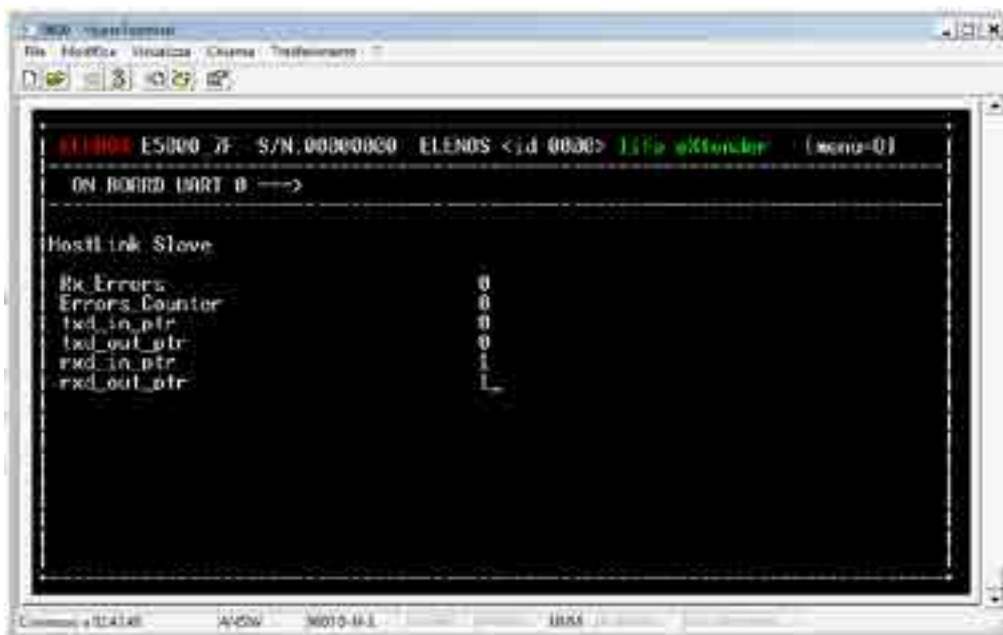

Main Menü
Debug (D)
Uarts (F)
Uart 1



Main Menü
Debug (D)
Uarts (F)
Uart 2

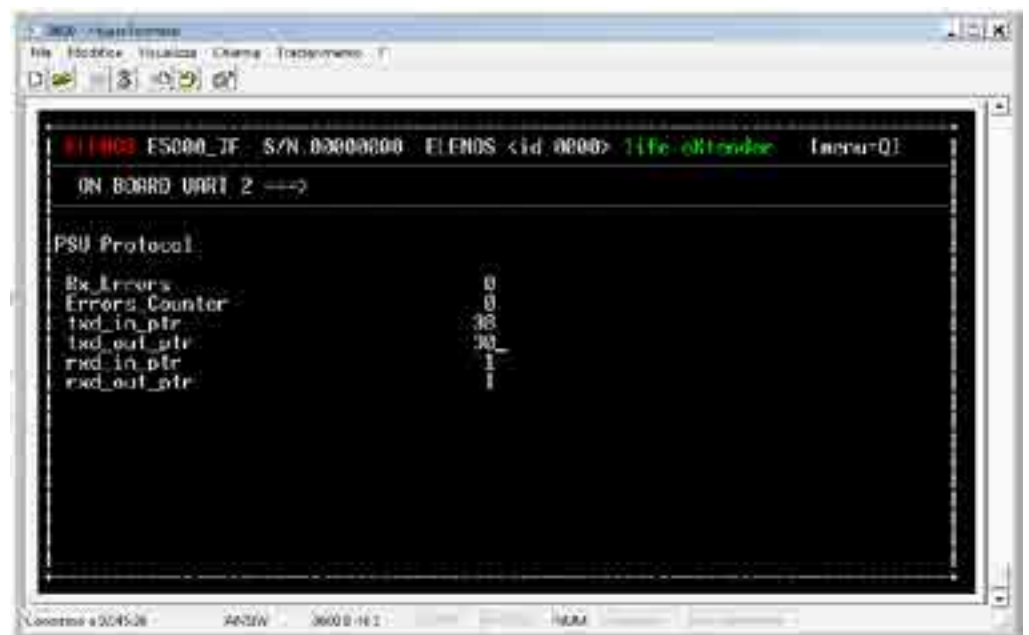

3.4.1.3 Exciter hyperterminal interface

For further information, please consult the specific manual for the exciter.

3.4.2 Connection to telemetry

This connection allows remote control through a device especially designed for that purpose.

The telemetry unit performs the energy backup for the continuous operation of the modem and is equipped with all the utilities for the general control of the parameters of other equipment and the work station.

To telemetry connection a cable (ELENOS code **CAB0281-0**) must be inserted into "EIA485" connector, DB9, on the rear panel of exciters and combiner.

This cable is supplied with the telemetry unit.

The connection can also be made when the machine is operating.

For further information please refer to the telemetry unit manual.

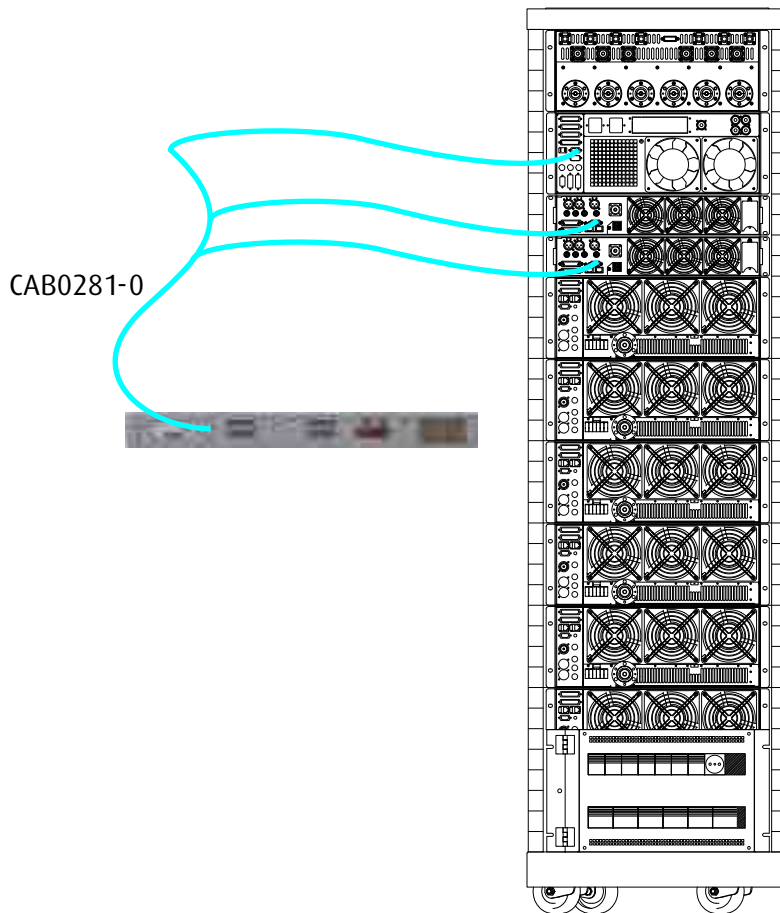

3.4.3 Connection to exchange unit and/or audio matrix

This connection allows the transmitter to be used in a system which provides for the exchange of a faulty transmitter with a spare one.

In order to connect to an N+1 exchange unit, if the equipment is not a spare, insert a standard extension cable into a "TC/TS" connector, DB25, located on the rear panel of the control unit (ELENOS code **CAB0324-0**).

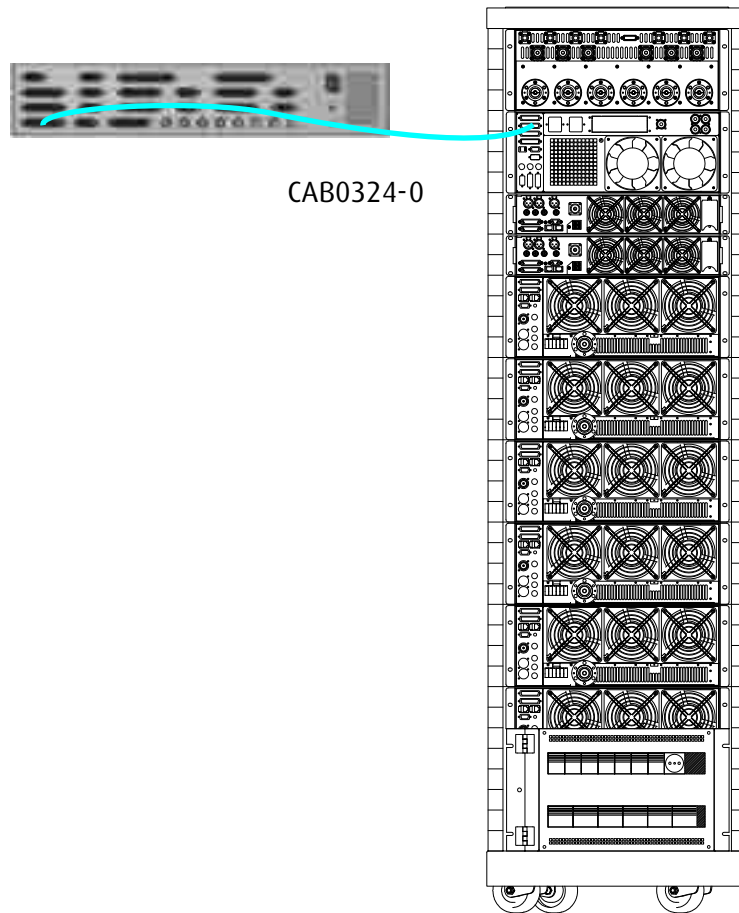

If the equipment is used as a spare, also provide an additional standard extension cable to be inserted into the "PROFILES" connector, DB25, located on the rear panel of the control unit (ELENOS code **CAB0324-0**).

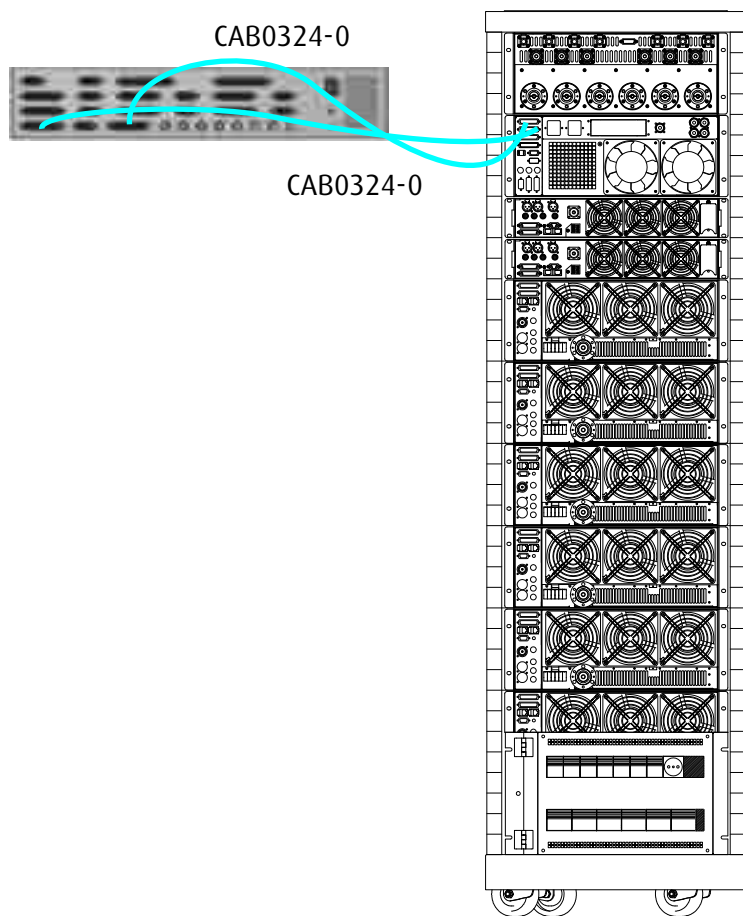

If the system has an audio matrix, this latter cable must be connected the matrix itself and not to the exchange unit.

These cables are supplied with the exchange unit.

The signal cables can also be connected when the equipment is working, excluding all RF cables.

For more information, please refer to the exchange unit manual.

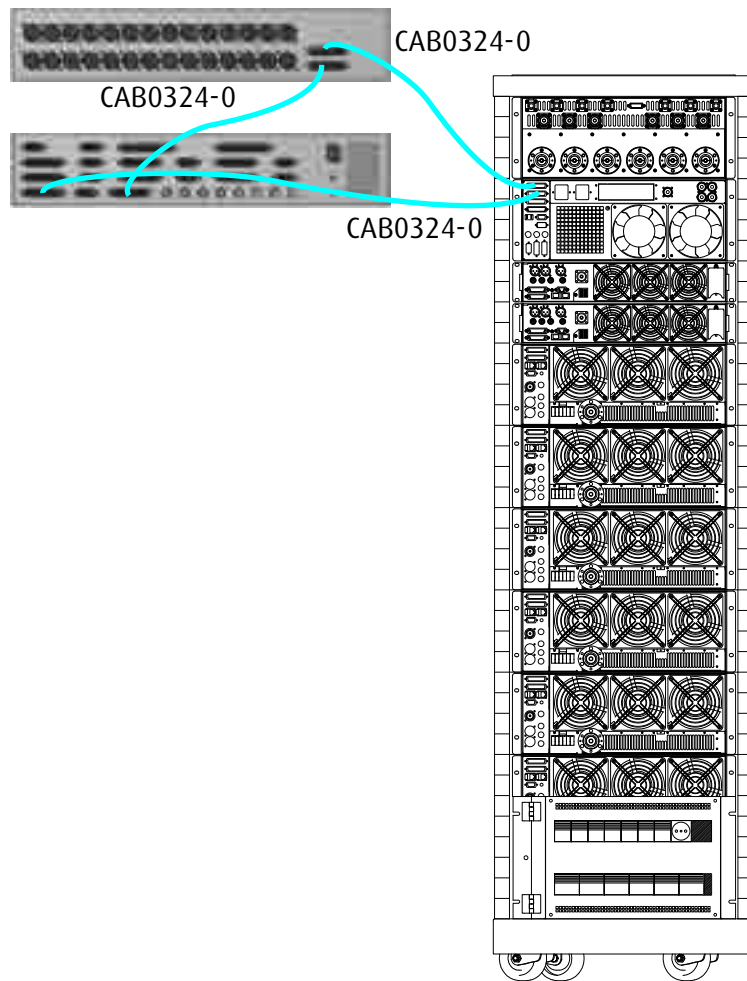

3.4.4 Connection to Elenos E.BOX module

This connection allows to have a “bridge” between the EIA485 bus of the equipment and the Ethernet network.

To connect to the E.BOX module, insert a standard extension cable into the “EIA485” connector, DB9, located on the front or rear panel of the control unit (Elenos code **ETGSAL33**).

This cable is supplied with the module.

The connection can also be made when the machine is operating.

For further information, please refer to the E.BOX module manual.

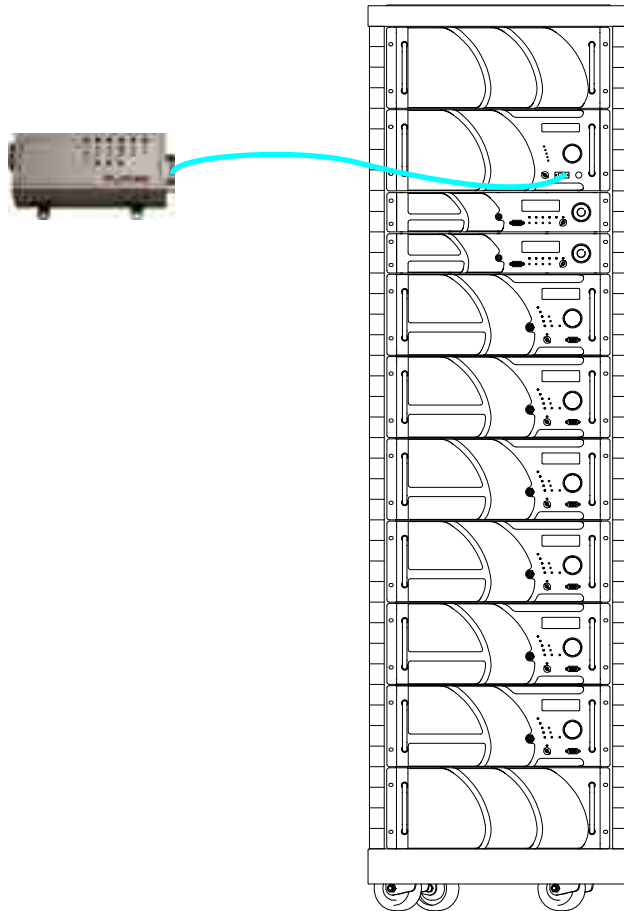

4 Maintenance

4.1 Device overview

We report here the images of how, less than specific customizations, the apparatus out by the manufacturer.

If necessary, refer to these to restore the configuration of the transmitter.

The figures are relative to the more complex case of ET30000-5 and its subparts.

For more details, to carry out repairs, if you are an authorized technician or bodies, you can request at the Manufacturer the Service Manual, including wiring diagrams.

4.1.1 ET30000-5



4.1.2 6-way combiner

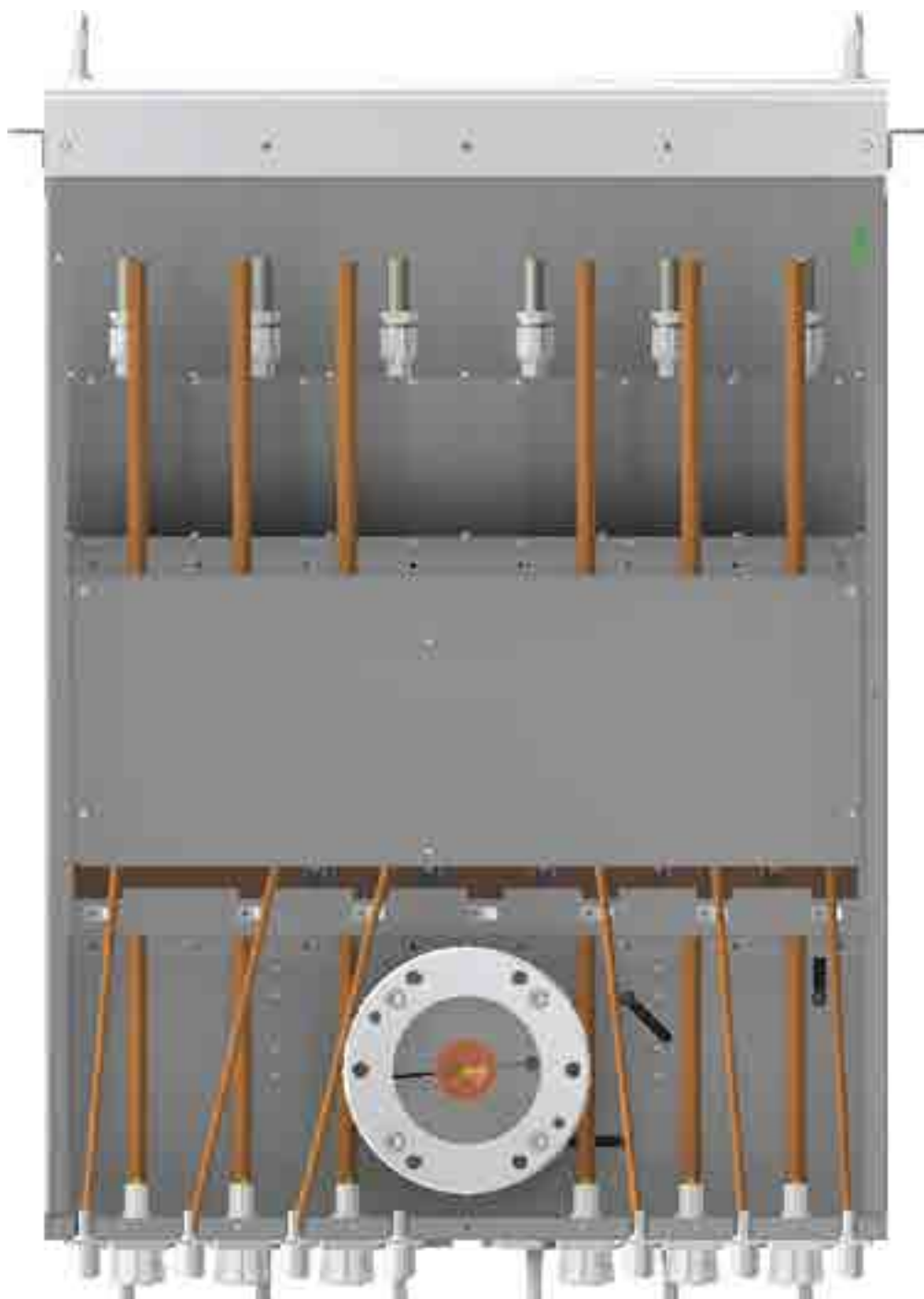

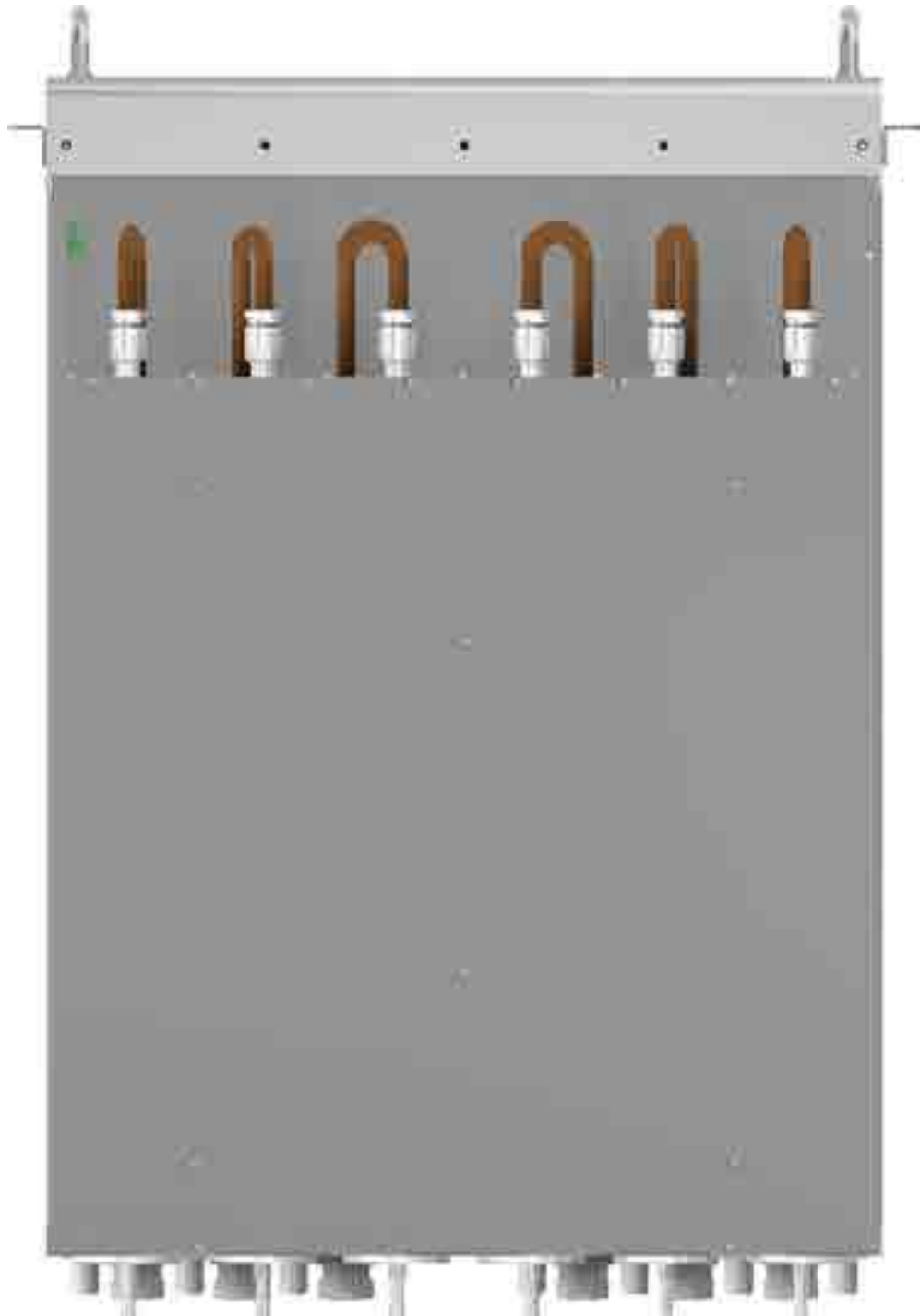

4.1.3 Control unit







4.1.4 ETG20 exciter





4.1.5 E5000 amplifier







4.1.6 6-way dummy load











4.2 Settings

4.2.1 System addresses

In the case of single combined transmitter (not in a N+1 system), addressing rules are those in the diagram below.

For operation in an N +1 system, however, refer to Technical Bulletin N°142.

Control unit		FRONT ID : 00 TC/TS ID : 00
Exciter 1		FRONT ID : 18 (10+8) TC/TS ID : 11
Exciter 2		FRONT ID : 19 (10+9) TC/TS ID : 12
Amplifier 1		FRONT ID : 11 (10+1) TC/TS ID : 01
Amplifier 2		FRONT ID : 12 (10+2) TC/TS ID : 02
	• • • • • •	
Amplifier n		FRONT ID : 10+n TC/TS ID : 0n

4.2.2 Power supply Dip-switch in E5000 amplifier

In the amplifier inside the system there are three 3KW power supplies. On the power supplies must set the operating mode (analog, digital), using the dip-switch SW1, and the address, using the dip-switch SW2.

	SW1				SW2			
	Switch1	Switch2	Switch3	Switch4	Switch1	Switch2	Switch3	Switch4
Power supply N.1	OFF	OFF	OFF	OFF	ON	OFF	OFF	OFF
Power supply N.2	OFF	OFF	OFF	OFF	OFF	ON	OFF	OFF
Power supply N.3	OFF	OFF	OFF	OFF	ON	ON	OFF	OFF

Dip-switch setting parameters



4.3 Spare parts and mounting

Refer to the Spare Parts manuals, technical bulletins, e-learning videos and training courses provided by the Manufacturer.

4.4 Routine maintenance (cleaning, replacements, checks)

During normal operation, we recommend performing routine checks in order to verify that there are no critical operating conditions.

We recommend following the following schedule:

Frequency	Intervention
15 days	Filter cleaning (very dusty environment).
30 days	Filter cleaning (not very dusty environment).
	Check the direct and reflected output power.
	Check telemetry operates properly, if applicable.
	Check the RF modules operate properly.
6 months	Check the power supplies operate properly
	Check the fans work properly.
	Check the operating temperatures of the equipment.
12 months	Check the electric consumption.
	Check the output RF connector closes properly.
	Check the condition of the electric connections.
	Check that the fan blades and the air grille are clean (dusty environment). To be performed when the equipment is in Stand-by mode.
24 months	Filter washing (dusty environment).
	Filter washing (not very dusty environment).
	Filter replacement (dusty environment).

4.5 Operating faults (symptoms, causes and remedies)

Fault	Cause	Remedy
The equipment does not start	<ul style="list-style-type: none"> • Incorrect connection to the mains • Circuit breaker is not armed • Circuit breaker fuse fault and/or with flow not ok • Auxiliary power incorrect (MAINS LED on front panel off) • Fault in power stage 	<ul style="list-style-type: none"> • Replace the cables (if not ok) and fix its appropriately • Arm circuit breaker • Adapt circuit breaker • Call the manufacturer • Call the manufacturer
Amplifiers fault	<ul style="list-style-type: none"> • Amplifier is not properly connect to the mains • Amplifier is not in the correct position in the rack • No correct address • Amplifier is not correct wired 	<ul style="list-style-type: none"> • Replace the cable or connect to apparatus • Insert amplifier in the correct position (please see schematics in Identification and Quick Start Manual) • Set the correct address (please see User Manual) • Adapt signal and interlock cable (please see schematics in Identification and Quick Start Manual)
Exciters fault	<ul style="list-style-type: none"> • Exciter is not properly connect to the mains • Exciter is not in the correct position in the rack • No correct address • Incorrect parameters setting (power, frequency, Dual Driver configuration, exchange number exceeds the maximum allowable) 	<ul style="list-style-type: none"> • Replace the cable or connect to apparatus • Insert exciter in the correct position (please see schematics in Identification and Quick Start Manual) • Set the correct address (please see User Manual) • Set the correct parameters (please see Identification and Quick Start Manual)
Transmitter does not reach the required power	<ul style="list-style-type: none"> • Transmitter in Stand By • No interlock connection • Not correct setting for target power • Amplifiers deliver a non-homogeneous power • Exciters deliver incorrect piloting power 	<ul style="list-style-type: none"> • Set the devices in RF ON • Connect interlock connection in technical panel • Set the correct parameter (please see Identification and Quick Start Manual) • Call the manufacturer • Verify the setting and, if necessary, call the manufacturer
There is reflected power	<ul style="list-style-type: none"> • RF connections problem to combiner • Unbalancing problem to antenna load 	<ul style="list-style-type: none"> • Adapt RF connections (please see schematics in Identification and Quick Start Manual) • Adapt antenna connection system

Rack fan stopped	<ul style="list-style-type: none"> • Fan is not properly connect to the mains • Circuit breaker is not armed • Fan fault 	<ul style="list-style-type: none"> • Replace the cable or connect it • Arm circuit breaker • Call the manufacturer
No communication with telemetria/PC	<ul style="list-style-type: none"> • Combiner address incorrect • Connection cable not suitable • Parameters setting incorrect • Connection cable fault or interrupted 	<ul style="list-style-type: none"> • Set the correct address • Verify that the cable used is that provided by Elenos or an equivalent • Check correct parameters (please see User Manual) • Connect or change cable