

ProFXv2 Series Mixers

ProFX4v2 • ProFX8v2 • ProFX12v2

ProFX16v2 • ProFX22v2 • ProFX30v2

Mackie ProFXv2 Series mixers provide a comprehensive live sound solution, with models from 4- to 30-channels, covering a huge range of applications.

Delivering unmatched sound quality, ProFXv2 features all-new Mackie Vita™ preamps, which are virtually noiseless and designed specifically for the highly-dynamic world of live sound.

ProFXv2 also includes the immensely powerful new ReadyFX™ effect engine, harnessing floating-point DSP to deliver 16 rich effects that elevate any performance.

The ProFXv2 no-compromise live sound toolkit includes a room-shaping GEQ, flexible I/O and a built-in USB interface for hassle-free recording/playback¹.

With a rugged steel chassis and unmatched sonic performance, ProFXv2 is truly the life of your live mix.



APPLICATIONS

Live sound mixing, houses of worship, clubs, gymnasiums, banquet halls, conference rooms, boardrooms, studio and field recording, video post-production, multimedia applications, broadcast, and many, many more.



Like us



Follow us



Watch our dang videos

¹ Available on ProFX8v2, ProFX12v2, ProFX16v2, ProFX22v2, ProFX30v2.

FEATURES:

- **Unmatched Sound Quality**
 - Extremely low-noise Mackie Vita™ mic preamps designed to add life to any input
 - All-new ReadyFX™ effects engine with 16 great-sounding effects like reverbs, delays and choruses
 - Single-knob channel compression for smooth, even dynamic control¹
- **No-Compromise Live Mixing Toolkit**
 - Graphic EQ for tuning mains or monitors
 - Built-in USB interface to record the show or provide music playback²
 - 4 flexible subgroups for professional mix management¹
 - Aux output(s) perfect for driving a monitor mix, fill speakers and more
 - Additional stereo channels
 - Extra stereo/aux return for external effects or stereo playback devices²
 - High-headroom line level inputs
 - Individual channel mutes and overload indication²
 - Channel inserts for connecting outboard processing²
 - EQ on all channels
 - 60mm faders²
 - Directly connect guitar, bass and other instruments via Hi-Z input³
 - 100Hz low-cut filter and 48V phantom power on all mic channels
 - Stereo RCA tape I/O with input level control
 - Headphone output with separate level control³
 - Control room / headphone outs with level control¹
 - Balanced XLR and/or balanced/unbalanced 1/4-inch main outputs
 - FX mute with remote control via footswitch⁴
 - Break switch mutes all channels for music playback between sets²
- **No-Hassle USB Recording/Playback²**
 - Built in USB recording interface with simple setup via Mac or PC
 - o Choose to record subgroups 1/2 or main L/R mix¹
 - o Separate USB input level control to mains²
 - o USB routable to full-featured channel strip¹
 - Great for live recording and perfect for home studios
 - Stream playback music for live or studio applications
 - Includes user-friendly Tracktion® recording software
- **Rugged, Roadworthy Design**
 - Legendary Mackie “Built-Like-A-Tank” design
 - Solid steel chassis protects your investment
 - Tough ABS side protection
 - Robust internal multi-voltage power supply²

¹ Available on ProFX16v2, ProFX22v2, ProFX30v2.

² Available on ProFX8v2, ProFX12v2, ProFX16v2, ProFX22v2, ProFX30v2.

³ Available on ProFX4v2, ProFX8v2, ProFX12v2.

⁴ Available on ProFX8v2, ProFX12v2, ProFX16v2, ProFX22v2.

PROFX^{v2} SERIES SPECIFICATIONS

Noise Characteristics

Equivalent Input Noise (EIN) (150 Ω source impedance, 20 Hz to 20 kHz)	
Mic in to FX send, max gain	-128 dBu ¹
Mic in to insert send out, max gain	-125 dBu ²
Mic in to insert send out, max gain	-128 dBu ³
Residual Output Noise	
All outputs, master levels off, all channel levels off	-95 dBu
All outputs, master levels unity, one channel level unity	-85 dBu ⁴ -80 dBu ²

Frequency Response

Mic input to any output (gain at unity, +0 dB / -1 dB)	
	20 Hz to 40 kHz ⁴
	20 Hz to 30 kHz ²

Distortion (THD+N)

(22 Hz to 80 kHz bandwidth)	
Mic in to Main out (+4 dBu output)	<0.01% ⁴ <0.03% ²

Attenuation and Crosstalk

Adjacent Inputs @ 1 kHz	-80 dB ¹ -90 dB ⁵
Inputs to Outputs @ 1 kHz	-80 dB
Fader Off @ 1 kHz	-80 dB ¹ -75 dB ⁵
Mute Switch / Break Switch Mute @ 1 kHz	-90 dB ² -100 dB ³

Common Mode Rejection Ratio (CMRR)

Mic In to Main Out, max gain, 1 kHz	70 dB
-------------------------------------	-------

Maximum Levels

All inputs	+22 dBu
Main Out	+22 dBu ¹
Main Out XLR	+28 dBu ⁵
All other outputs	+22 dBu

Impedances

Mic In	3.3 kΩ ³ 3.8 kΩ ⁶
Channel Insert Return	10 kΩ ⁵
All other inputs	≥20 kΩ
Tape output	1 kΩ
Phones output	25 Ω
All other outputs	120 Ω Unbalanced, 240 Ω Balanced

¹ ProFX4v2.

² ProFX8v2, ProFX12v2.

³ ProFX16v2, ProFX22v2, ProFX30v2.

⁴ ProFX4v2, ProFX16v2, ProFX22v2, ProFX30v2.

⁵ ProFX8v2, ProFX12v2, ProFX16v2, ProFX22v2, ProFX30v2.

⁶ ProFX4v2, ProFX8v2, ProFX12v2.

Equalization

ProFX4v2 • ProFX8v2 • ProFX12v2	
Low	±15 dB @ 80 Hz
Mid [ProFX8/12v2]	±15 dB @ 2.5 kHz
High	±15 dB @ 12 kHz
Low Cut Filter	18 dB/octave @ 100 Hz
ProFX16v2 • ProFX22v2 • ProFX30v2	
Mono Channels	
Low	±15 dB @ 80 Hz
Mid	±15 dB
	100 Hz - 8 kHz
High	±15 dB @ 12 kHz
Low Cut Filter	18 dB/octave @ 100 Hz
Stereo Channels	
Low	±15 dB @ 80 Hz
Mid	±15 dB @ 2.5 kHz
High	±15 dB @ 12 kHz

Maximum Voltage Gain (EQ Flat)

Mic input Channel to	
Insert Output	50 dB
Tape Output	60 dB
USB Output	50 dB ² 60 dB ³
1/4" Main Output	70 dB
XLR Main Output	76 dB
Monitor Send	76 dB ⁶ 81 dB ³
FX Send	75 dB ¹ 90 dB ⁵
Mono Line Input Channel to	
Insert Output	30 dB
Tape Output	40 dB
USB Output	30 dB ² 40 dB ³
XLR Main Output	56 dB
Monitor Send	56 dB ⁶ 61 dB ³
FX Send	55 dB ¹ 70 dB ⁵
Stereo Line Input Channel to	
Tape Output	30 dB
USB Output	30 dB ⁵
XLR Main Output	46 dB
Monitor Send	46 dB ⁶ 51 dB ³
FX Send	45 dB ¹ 60 dB ² 55 dB ³
Tape Input to	
Main Output	30 dB ¹
XLR Main Output	36 dB ⁵
USB Input to	
Main Output	30 dB ¹
XLR Main Output	36 dB ⁵
Stereo Return to	
Mon Output	30 dB ³
XLR Main Output	26 dB ⁵

PROFX^{v2} SERIES SPECIFICATIONS SPECIFICATIONS continued...

Digital Effects

I/O	Mono input / Stereo output
Number of Presets	16

Meters

Main L/R Mix	
Two columns of 12 segments each:	
OL (+20 dBu), +15, +10, +6, +3, 0 (0 dBu), -2, -4, -7, -10, -20, -30	
Channel OL LED ⁵	
Measured post-EQ, pre-fader (-3 dB before channel clipping)	18 dBu

Graphic EQ

Frequency Centers [5-Band] ¹	80, 250, 800, 2.5k, 8k
Frequency Centers [7-Band] ⁵	125, 250, 500, 1k, 2k, 4k, 8k
Gain	±15 dB
Assignable to Main or Monitor, bypassable	

USB⁵

Format	USB 1.1
I/O	Stereo Input / Stereo Output
A/D/A	16 Bit, 44.1 kHz / 48 kHz

Phantom Power

48 VDC to all Mic channels simultaneously	
---	--

AC Power Requirements

Power Consumption	20 watts [ProFX8v2] 30 watts [ProFX12v2] 40 watts [ProFX16v2] 45 watts [ProFX22v2] 50 watts [ProFX30v2]
Universal AC Power Supply Class I Hard-Wired Wall Wart ¹ Class II Detachable Line Cord ⁵	100 – 240 VAC, 50 – 60 Hz [12VDC @ 1.5A]
Operating Temperature	0° – 40°C 32° – 104°F

Physical Properties (packaged product)

ProFX4v2	
Height	4.0 in / 102 mm
Width	12.3 in / 312 mm
Depth	12.2 in / 310 mm
Weight	4.7 lb / 2.1 kg

ProFX8v2	
Height	7.0 in / 178 mm
Width	15.6 in / 396 mm
Depth	17.9 in / 455 mm
Weight	10.0 lb / 4.5 kg

ProFX12v2	
Height	7.0 in / 178 mm
Width	18.8 in / 478 mm
Depth	18.0 in / 457 mm
Weight	12.0 lb / 5.4 kg

ProFX16v2	
Height	8.1 in / 206 mm
Width	22.0 in / 559 mm
Depth	20.1 in / 511 mm
Weight	19.0 lb / 8.6 kg

ProFX22v2	
Height	8.1 in / 206 mm
Width	28.4 in / 721 mm
Depth	20.4 in / 518 mm
Weight	24.5 lb / 11.1 kg

ProFX30v2	
Height	8.3 in / 211 mm
Width	37.4 in / 950 mm
Depth	20.9 in / 531 mm
Weight	34 lb / 15.4 kg

PROFX^{v2} SERIES SPECIFICATIONS SPECIFICATIONS continued...
Physical Properties (product)
ProFX4v2

Height	2.9 in / 73 mm
Width	8.7 in / 220 mm
Depth	10.1 in / 256 mm
Weight	3.2 lb / 1.4 kg

ProFX8v2

Height	3.6 in / 91 mm
Width	11.4 in / 290 mm
Depth	14.1 in / 358 mm
Weight	7.1 lb / 3.2 kg

ProFX12v2

Height	3.6 in / 91 mm
Width	14.6 in / 370 mm
Depth	14.1 in / 358 mm
Weight	9.0 lb / 4.1 kg

ProFX16v2

Height	3.8 in / 97 mm
Width	18.7 in / 475 mm
Depth	16.0 in / 407 mm
Weight	13.0 lb / 5.9 kg

ProFX22v2

Height	3.8 in / 97 mm
Width	25.1 in / 639 mm
Depth	16.0 in / 407 mm
Weight	18.0 lb / 8.2 kg

ProFX30v2

Height	3.8 in / 97 mm
Width	33.6 in / 853 mm
Depth	16.6 in / 422 mm
Weight	25 lb / 11.4 kg

Options
ProFX4v2

Bag	P/N 2036809-29
-----	----------------

ProFX8v2

Bag	P/N 0020636
Cover	P/N 0020638

ProFX12v2

Bag	P/N 0020637
Cover	P/N 0020639
Rack Ear Kit	P/N 2045757-00

ProFX16v2

Bag	P/N 2036809-10
Cover	P/N 2036809-12
Rack Ear Kit	P/N 2036168-00

ProFX22v2

Bag	P/N 2036809-11
Cover	P/N 2036809-13

ProFX30v2

Cover	P/N 2036809-30
-------	----------------

Ordering Information
ProFX4v2 4-channel Professional Effects Mixer

US	P/N 2044600-00
EU	P/N 2044600-01
JP	P/N 2044600-02
UK	P/N 2044600-03
AU	P/N 2044600-04
CN	P/N 2044600-05
BZ (~120V)	P/N 2044600-06

ProFX8v2 8-channel Professional Effects Mixer with USB

US	P/N 2044601-00
EU	P/N 2044601-01
UK	P/N 2044601-03
CN	P/N 2044601-05
BZ (~120V)	P/N 2044601-06

ProFX12v2 12-channel Professional Effects Mixer with USB

US	P/N 2044602-00
EU	P/N 2044602-01
UK	P/N 2044602-03
CN	P/N 2044602-05
BZ (~120V)	P/N 2044602-06

ProFX16v2 16-channel 4-Bus Effects Mixer with USB

US	P/N 2044603-00
EU	P/N 2044603-01
UK	P/N 2044603-03
CN	P/N 2044603-05
BZ (~120V)	P/N 2044603-06

ProFX22v2 22-channel 4-Bus Effects Mixer with USB

US	P/N 2044604-00
EU	P/N 2044604-01
UK	P/N 2044604-03
CN	P/N 2044604-05
BZ (~120V)	P/N 2044604-06

ProFX30v2 30-channel 4-Bus Effects Mixer with USB

US	P/N 2044605-00
EU	P/N 2044605-01
UK	P/N 2044605-03
CN	P/N 2044605-05
BZ (~120V)	P/N 2044605-06

ProFX4v2, ProFX8v2, ProFX12v2 and ProFX16v2 DIMENSIONS

THIRD ANGLE PROJECTION

UNLESS OTHERWISE SPECIFIED, ALL DIMENSIONS ARE IN INCHES DUAL (MM) DIMENSIONS FOR REF ONLY

TOLERANCE IN INCHES LINEAR ± 0.13 (in) / ± 3.3 (mm) ANGLES ± 1°

(X.XX) = REF DIMS NO TOLERANCE IMPLIED

TSC = THEORETICAL SHARP CORNER

DIMENSIONS ACROSS CENTERLINES TO BE SYMMETRICAL

THE INFORMATION CONTAINED HEREIN IS PROPRIETARY AND CONFIDENTIAL PROPERTY OF LOUD TECHNOLOGIES, INC. ALL RIGHTS RESERVED

- ProFX4v2 NOTES:
1. WEIGHT APPROX. 3.2 lb [1.4 kg]
 2. SHIPPING WEIGHT APPROX. 4.7 lb [2.1 kg]

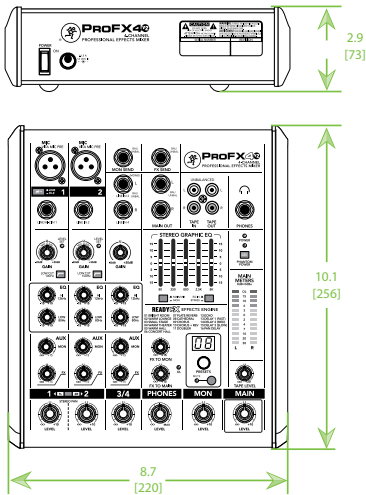

- ProFX8v2 NOTES:
1. WEIGHT APPROX. 7.1 lb [3.2 kg]
 2. SHIPPING WEIGHT APPROX. 10.0 lb [4.5 kg]

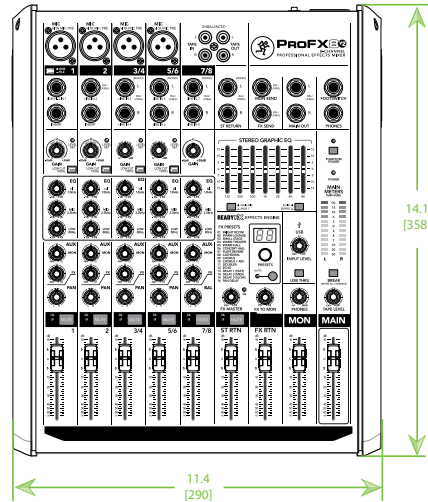
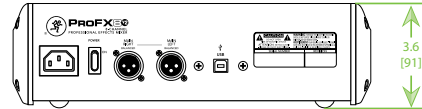

- ProFX12v2 NOTES:
1. WEIGHT APPROX. 9.0 lb [4.1 kg]
 2. SHIPPING WEIGHT APPROX. 12.0 lb [5.4 kg]

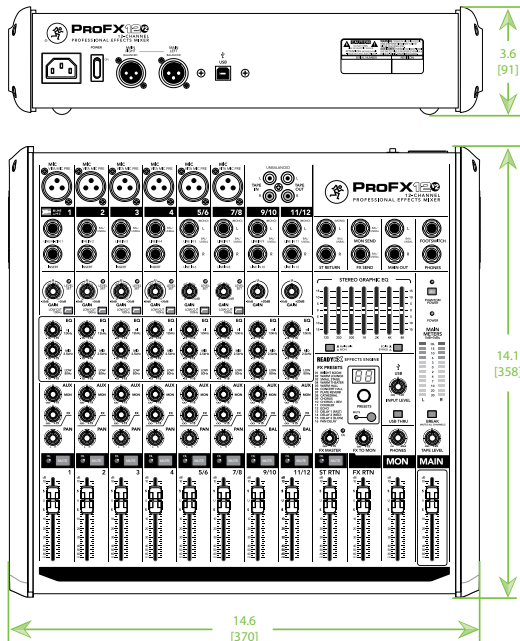

- ProFX16v2 NOTES:
1. WEIGHT APPROX. 13.0 lb [5.9 kg]
 2. SHIPPING WEIGHT APPROX. 19.0 lb [8.6 kg]

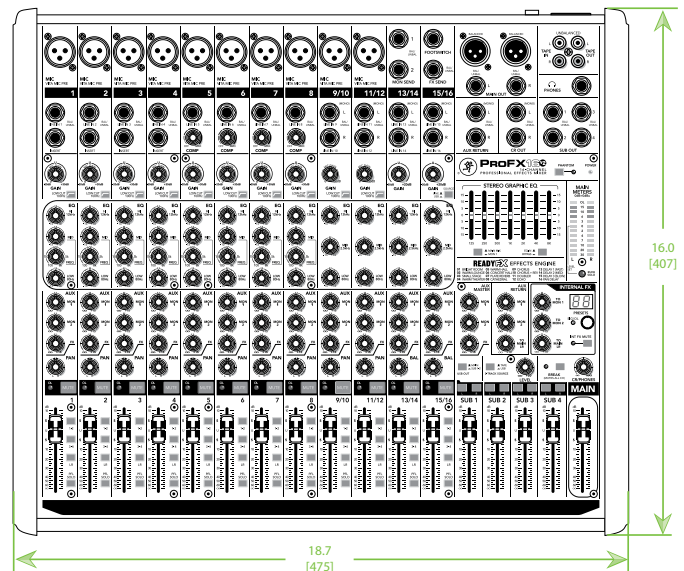
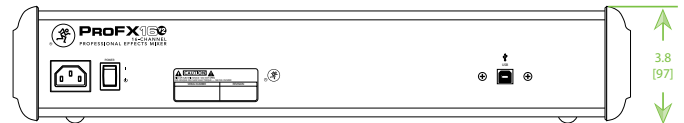

ProFX22v2 and ProFX30v2 DIMENSIONS

ProFX22v2 NOTES:

1. WEIGHT APPROX. 18.0 lb [8.2 kg]
2. SHIPPING WEIGHT APPROX. 24.5 lb [11.1 kg]

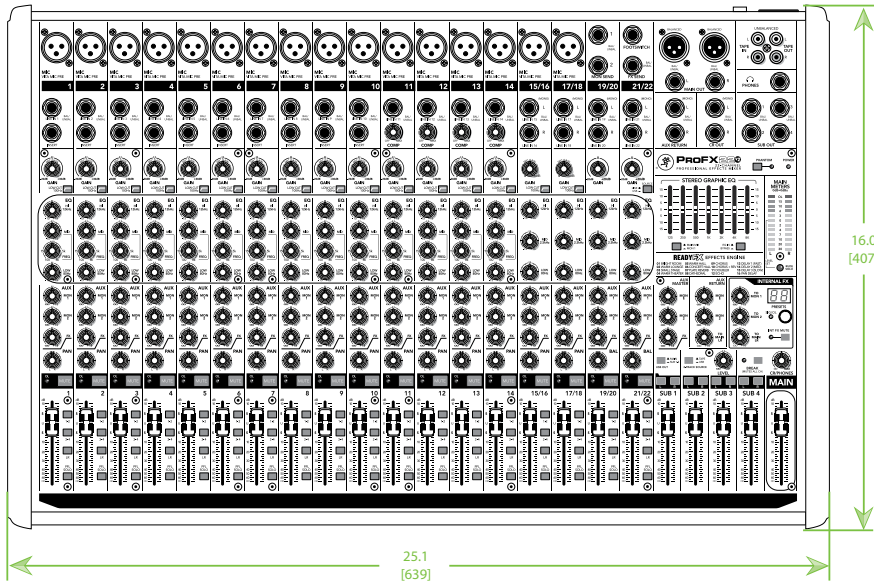
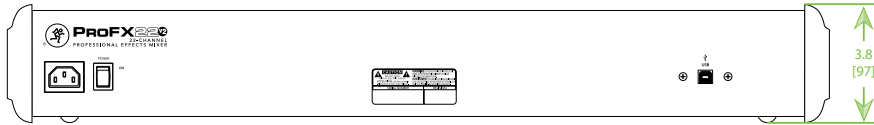

THIRD ANGLE PROJECTION

UNLESS OTHERWISE SPECIFIED:
ALL DIMENSIONS ARE IN INCHES
DUAL (MM) DIMENSIONS
FOR REF ONLY

TOLERANCE IN INCHES
LINEAR ± 0.13 in / ± 3.3 mm
ANGLES ± 1°

(X.XX) = REF DIMS
NO TOLERANCE IMPLIED

TSC = THEORETICAL SHARP CORNER

DIMENSIONS ACROSS CENTERLINES
TO BE SYMMETRICAL

THE INFORMATION CONTAINED
HEREIN IS PROPRIETARY AND
CONFIDENTIAL PROPERTY OF
LOUD TECHNOLOGIES, INC.
ALL RIGHTS RESERVED

ProFX30v2 NOTES:

1. WEIGHT APPROX. 25.0 lb [11.4 kg]
2. SHIPPING WEIGHT APPROX. 34.0 lb [15.4 kg]

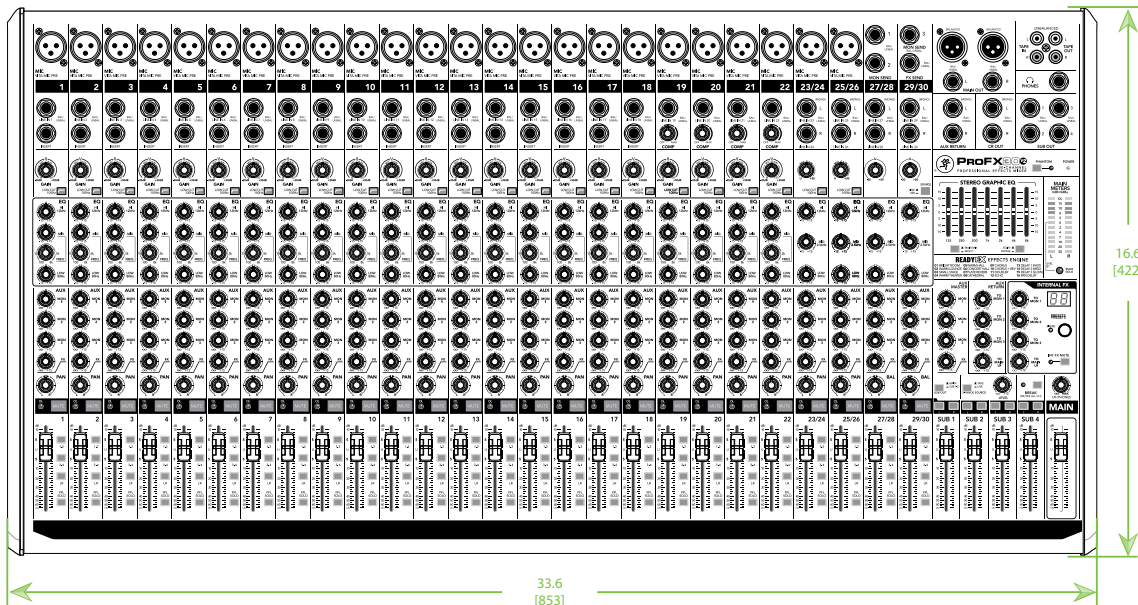
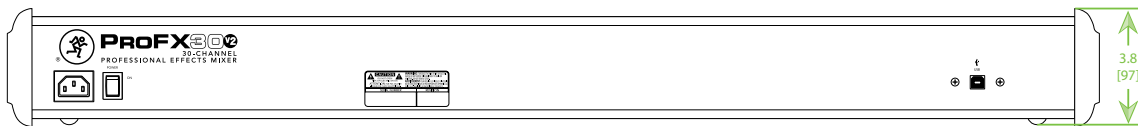

ProFX4v2 BLOCK DIAGRAM

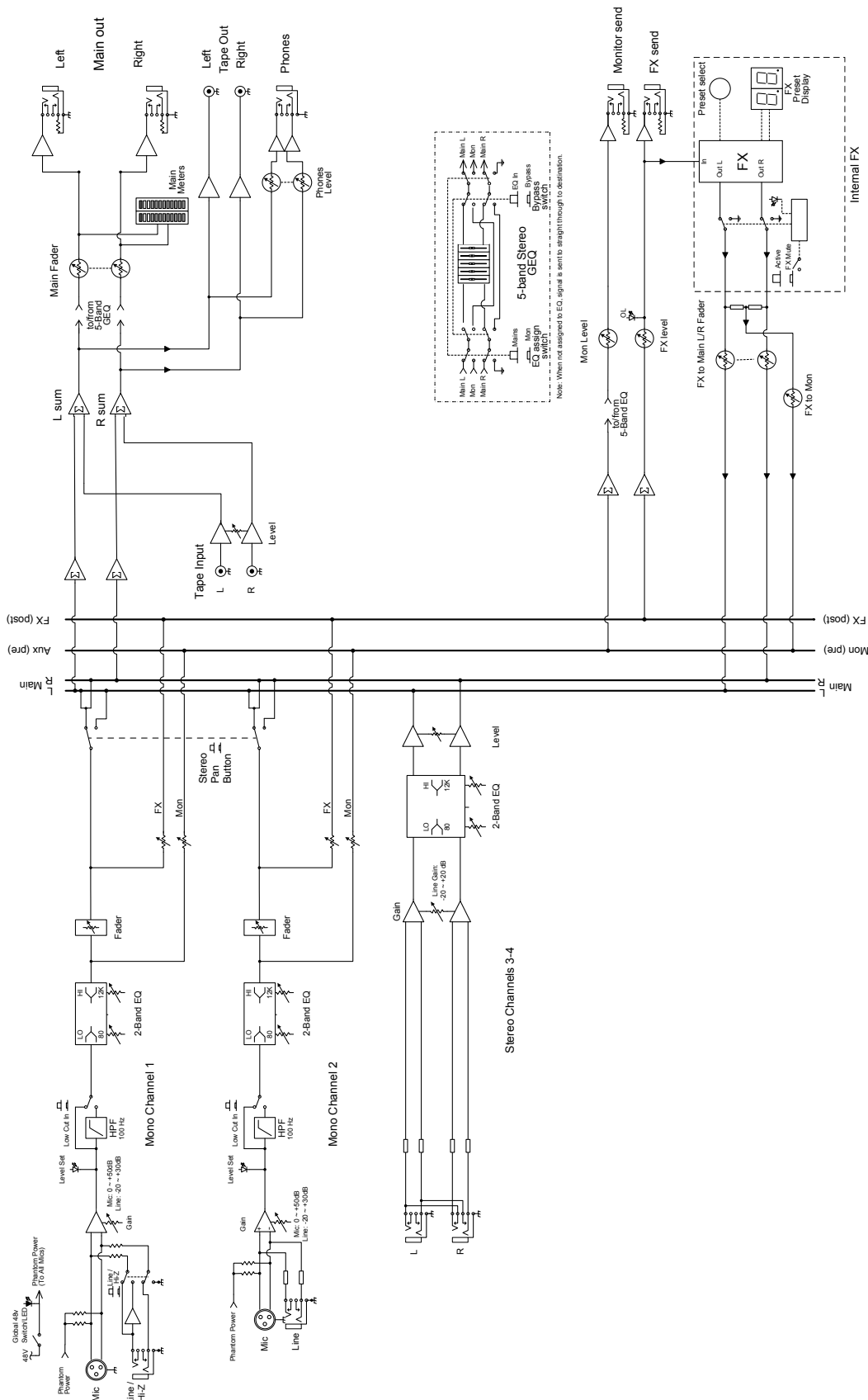

ProFX8v2 and ProFX12v2 BLOCK DIAGRAM

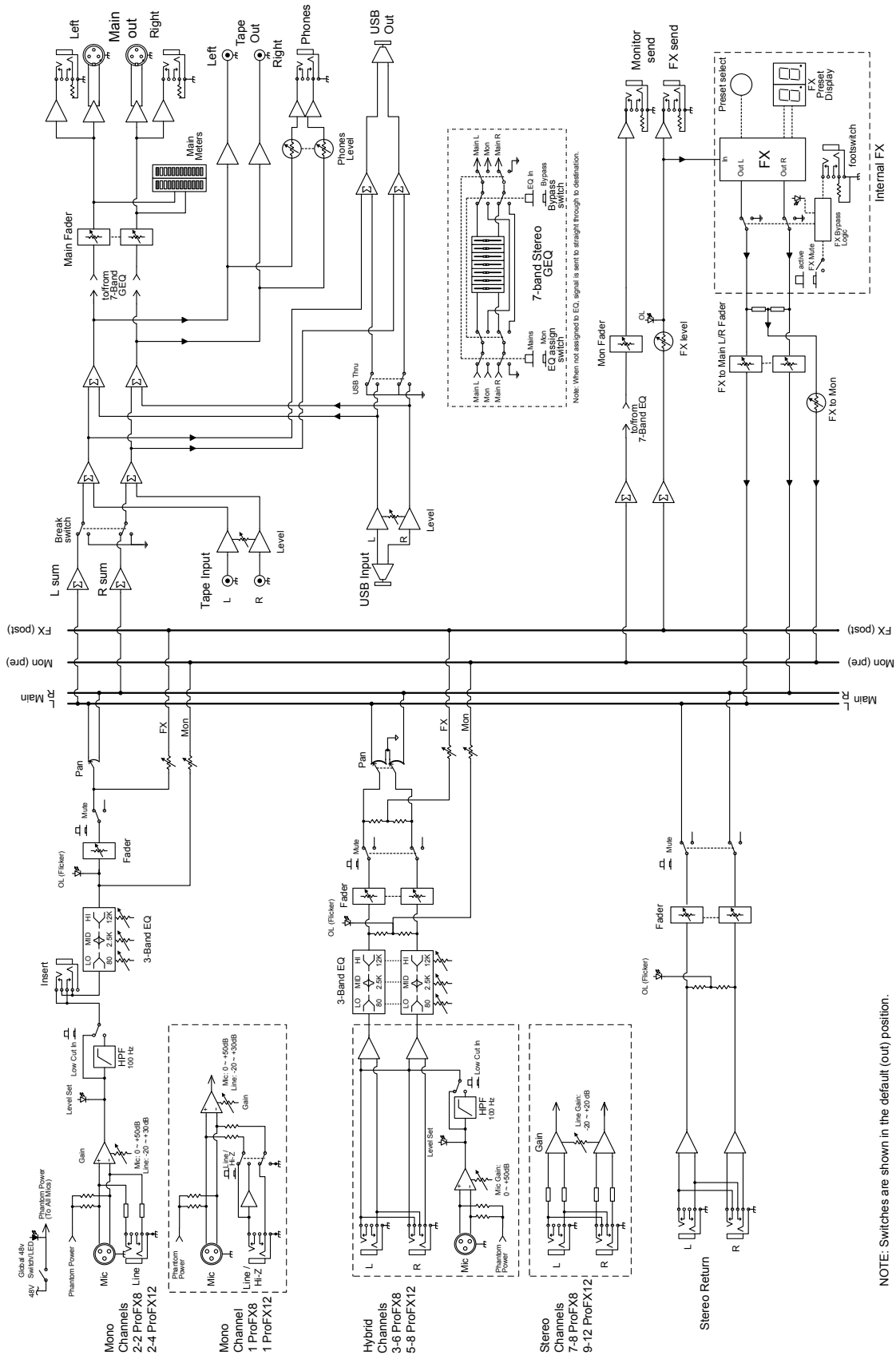

NOTE: Switches are shown in the default (out) position.

ProFX16v2 and ProFX22v2 BLOCK DIAGRAM

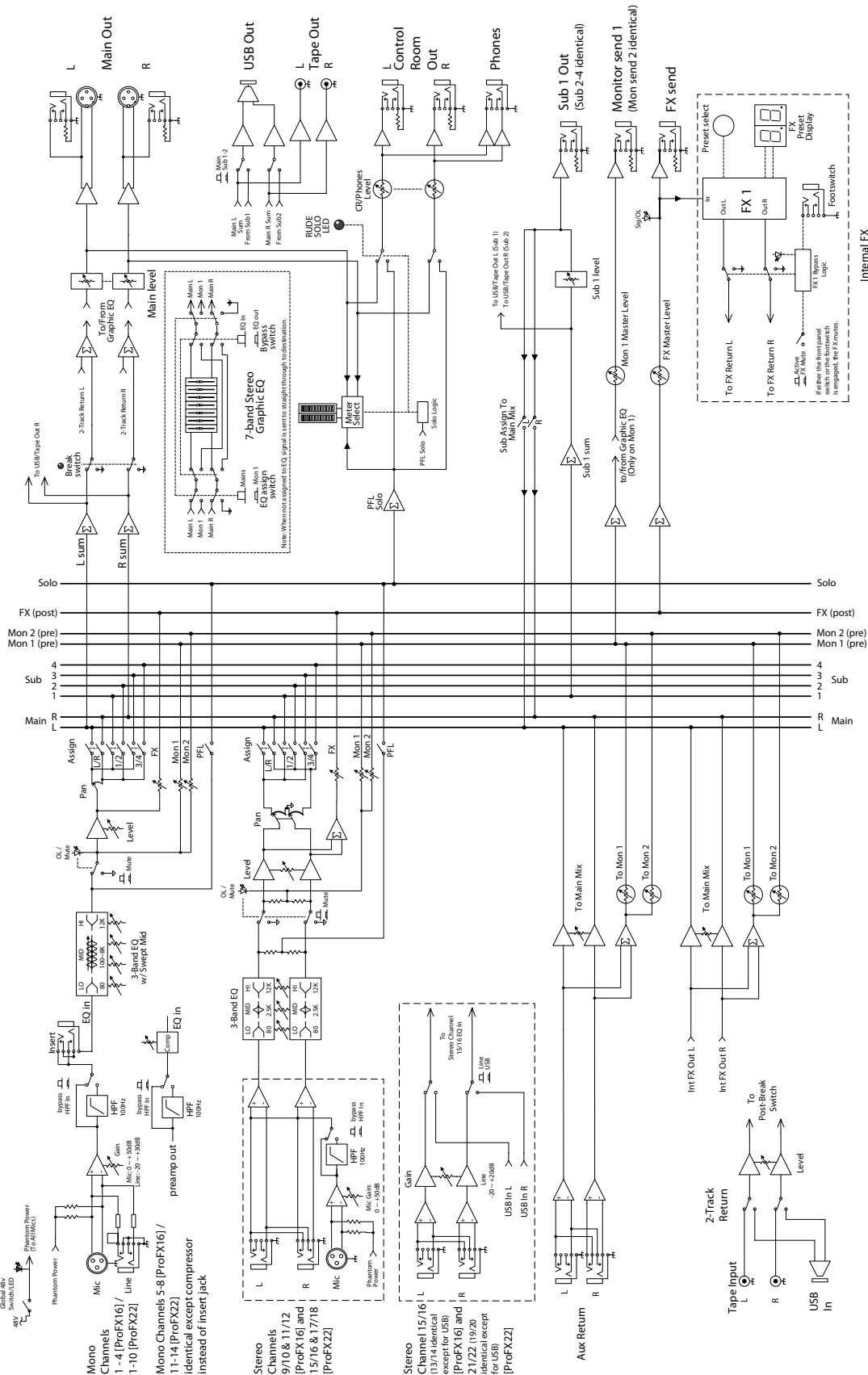

NOTE: Switches are shown in the default (out) position.

ProFX30v2 BLOCK DIAGRAM

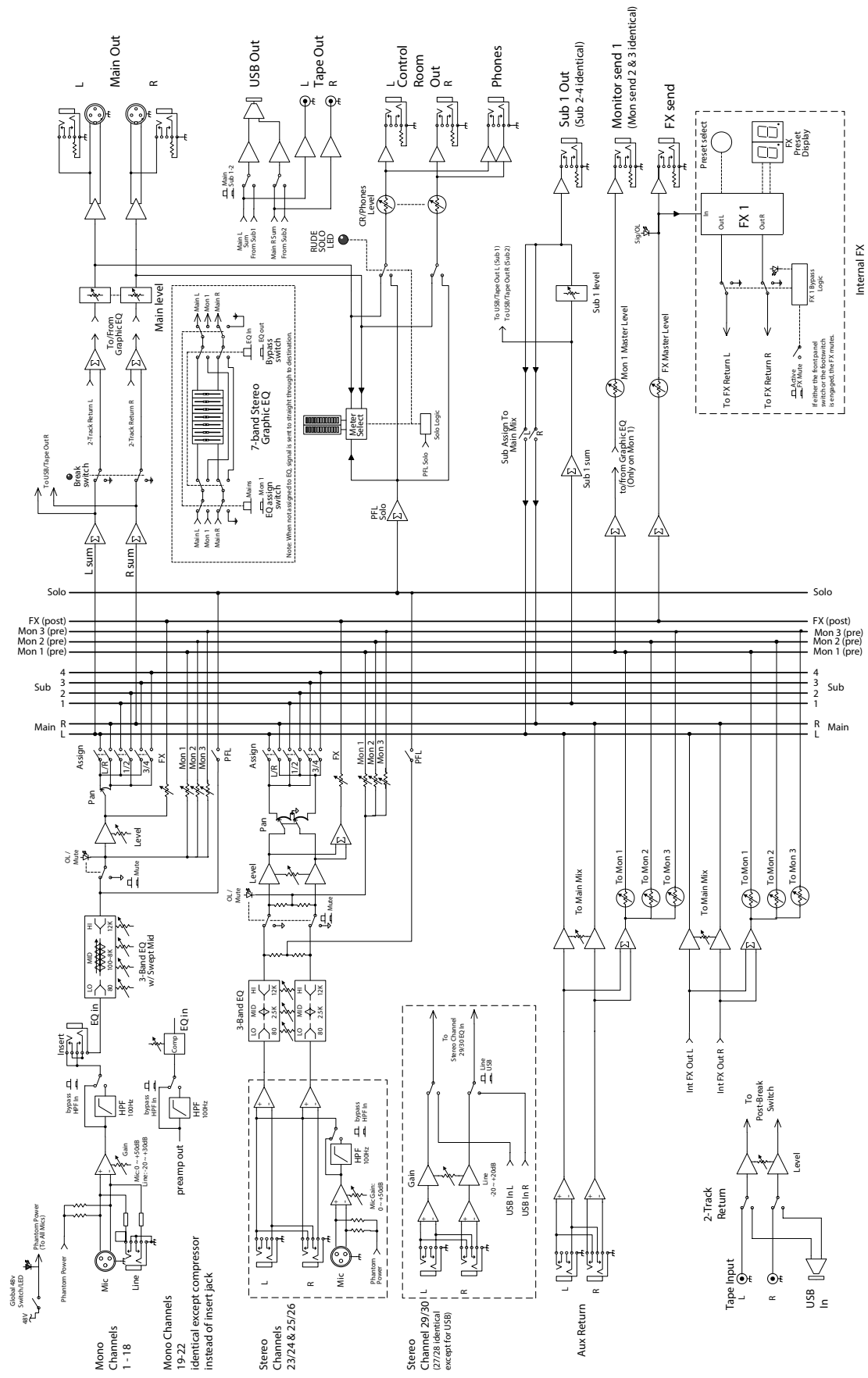



PROFX^{v2}SERIES

Professional Effects Mixers

MACKIE[®]

www.mackie.com

16220 Wood-Red Road NE

Woodinville, WA 98072 USA

800-898-3211, Fax 425-487-4337, sales@mackie.com

Part No. SWI084 Rev. B 04/15

Electronic files for this product are available at:

www.mackie.com

Specification Sheet	ProFXv2_SS.PDF
ProFX4v2 Owner's Manual	ProFX4v2_OM.PDF
ProFXv2 Series Owner's Manual	ProFXv2_Series_OM.PDF

Since we are always striving to make our products better by incorporating new and improved materials, components, and manufacturing methods, we reserve the right to change these specifications at any time without notice. "Mackie" and the "Running Man" figure are registered trademarks of LOUD Technologies Inc. All other brand names mentioned are trademarks or registered trademarks of their respective holders, and are hereby acknowledged.

©2015 LOUD Technologies Inc. All Rights Reserved.