

# Cave de Vinho W WC512

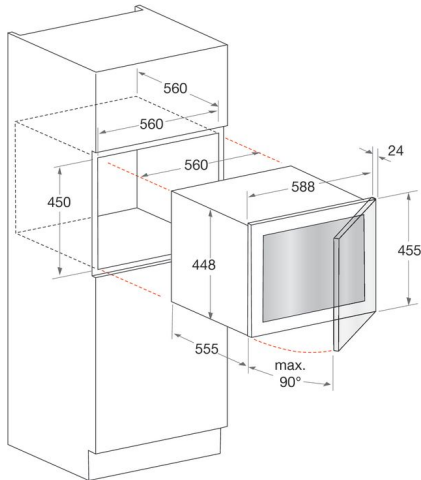

## 12 NC 859991595270 – W WC512

- Garrafeira de encastre de 60 cm
- Classe energética: A
- Capacidade de armazenamento 24 garrafas
- Sistema de antivibração
- Sistema de anticondensação
- Iluminação LED
- Puxador interior
- Display eletrónico no interior
- Capacidade bruta/líquida total: 66/64L
- Temperatura entre 4°C - 18°C

EAN 8003437604850

MEDIDAS 450 x 560 x 560 mm (AxLxP)