



# BD HARMONIA 50CL

BASIC PRODUCT

VINHOS

# BD HARMONIA 50CL

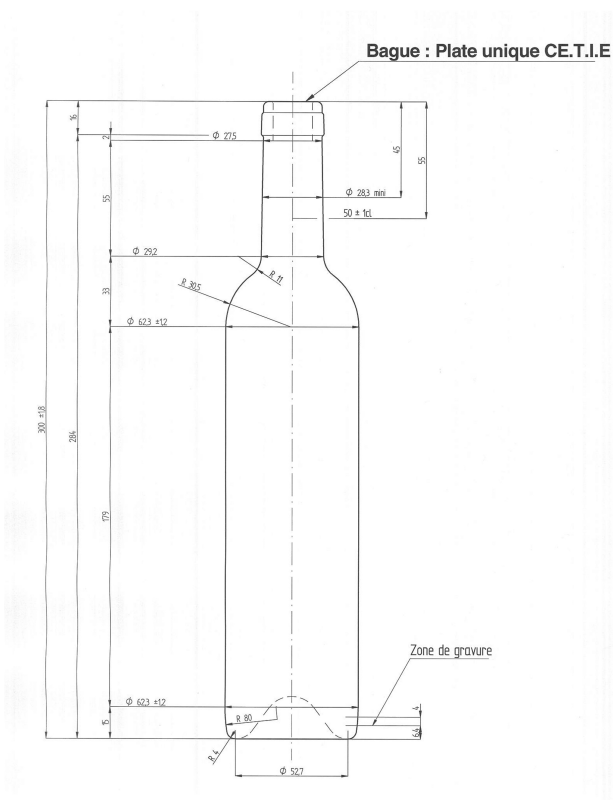

## CARACTERÍSTICAS TÉCNICAS

Capacidade (ml):	500
Cor:	Musgo
Peso (kg):	0,420
Boca:	18.5
Altura (mm):	300,00
Diâmetro Ombro (mm):	62,30
Diâmetro Base (mm):	62,30
Quantidade por Palete:	1 986



21.02.2024

[www.global-embalagem.pt](http://www.global-embalagem.pt) | [geral@global-embalagem](mailto:geral@global-embalagem)