



BEER MW 2L

PREMIUM PRODUCT

CERVEJA

BEER MW 2L

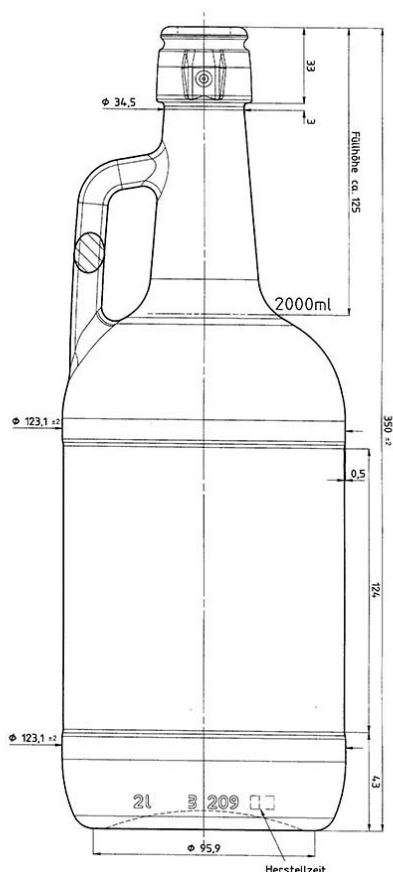

CARACTERÍSTICAS TÉCNICAS

Capacidade (ml):	2000
Cor:	Âmbar
Peso (kg):	1,400
Boca:	Corona
Altura (mm):	350,00
Diâmetro Ombro (mm):	123,10
Diâmetro Base (mm):	123,10
Quantidade por Palete:	315



21.02.2024

www.global-embalagem.pt | geral@global-embalagem