

**FG**

Bicycle thread  
DIN 79012



through holes & blind holes up to 1,5 x D

Chip removal (like picture)

Form C straight flutes

2-3 threads

outside cooling and lubrication

medium

to 800 N/mm<sup>2</sup>

TOL

N/mm<sup>2</sup>

HRC

medium

to 800 N/mm<sup>2</sup>

medium

to 800 N/mm<sup>2</sup>

medium

to 800 N/mm<sup>2</sup>

medium

to 800 N/mm<sup>2</sup>

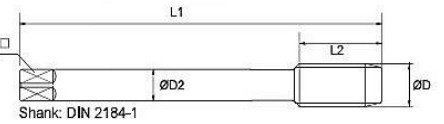

Machine Taps

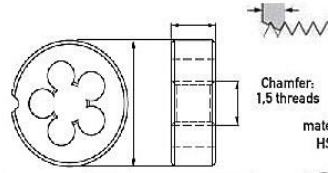

Round Dies

TOL medium

Chamfer: 1,5 threads

right hand thread

material: HSS



FG	D1	D2	L1	L2	□	✂	No.	€
FG 6,35 x 26	6,35	7,0	80	14	5,5	5,50	330501001	73,70
FG 7,9 x 26	7,90	8,0	90	16	6,2	7,00	330501002	78,95
FG 9,5 x 26	9,50	7,0	90	16	5,5	8,60	330501003	78,95
FG 14,3 x 20 right	14,30	11,0	100	22	9,0	13,10	330501004	84,21
FG 14,3 x 20 left	14,30	11,0	100	22	9,0	13,10	330501005	94,75
FG 25,4 x 24	25,40	14,0	110	22	11,0	24,50	330501006	*

FG	D	D1	H	D2	No.	€
FG 6,35 x 26	6,35	20	7	6,24	331401001	37,90
FG 7,9 x 26	7,90	25	9	7,82	331401002	53,70
FG 9,5 x 26	9,50	30	11	9,40	331401003	74,75
FG 14,3 x 20 right	14,30	38	10	14,40	331401004	114,75
FG 14,3 x 20 left	14,30	38	10	14,40	331401005	137,90
FG 25,4 x 24	25,40	55	16	25,25	331401006	312,63

**BSC**

British bicycle thread  
RS 811

**BSC**

**BSC**

British bicycle thread  
RS 811

BSC 1/4 x 26	6,35	6,0	56	14	4,9	5,55	340101001	73,70
BSC 5/16 x 26	7,94	6,0	63	16	4,9	7,10	340101002	78,95
BSC 3/8 x 26	9,53	7,0	63	16	5,5	8,65	340101003	78,95
BSC 9/16 x 20 right	14,29	11,0	70	22	9,0	13,15	340101004	84,21
BSC 9/16 x 20 left	14,29	11,0	70	22	9,0	13,15	340101005	94,74
BSC 1" x 24	25,40	14,0	70	22	11,0	24,50	340101006	*

BSC 1/4 x 26	6,35	20,6	6,35	6,24	341401001	37,90
BSC 5/16 x 26	7,94	25,4	9,5	7,82	341401002	53,70
BSC 3/8 x 26	9,53	25,4	9,5	9,40	341401003	74,75
BSC 7/16 x 26	11,11	25,4	9,5	10,98	341401004	*
BSC 9/16 x 20 right	14,29	38,1	12,7	14,14	341401005	114,75
BSC 9/16 x 20 left	14,29	38,1	12,7	14,14	341401006	137,90
BSC 1" x 24	25,40	55	16	25,25	341401007	312,63

\* on request

MACHOS E CAÇONETES HSS RD - RMS

**RD**

knuckle thread  
DIN 405

to 800 N/mm<sup>2</sup>



2-3 threads

outside cooling and lubrication

material: HSSG

to 800 N/mm<sup>2</sup>

2-3 threads

outside cooling and lubrication

material: HSSG

to 800 N/mm<sup>2</sup>

2-3 threads

outside cooling and lubrication

material: HSSG

to 800 N/mm<sup>2</sup>

2-3 threads

outside cooling and lubrication

material: HSSG

to 800 N/mm<sup>2</sup>

2-3 threads

outside cooling and lubrication

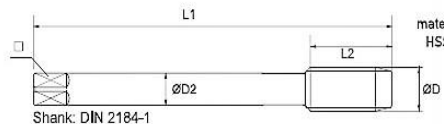

Machine Taps

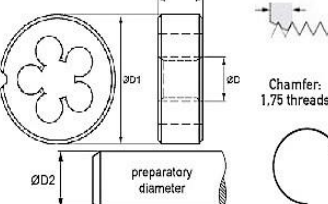

Round Dies

Chamfer: 1,75 threads

material: HSS



RD	D1	D2	L1	L2	□	✂	No.	€
Rd 8 x 1/10	8,25	6,0	90	26	4,9	5,71	350501001	77,40
Rd 9 x 1/10	9,25	7,0	90	26	5,5	6,71	350501002	77,40
Rd 10 x 1/10	10,25	7,0	100	28	5,5	7,71	350501003	77,40
Rd 11 x 1/10	11,25	8,0	100	28	6,2	8,71	350501004	94,75
Rd 12 x 1/10	12,25	9,0	110	28	7,0	9,71	350501005	105,25
Rd 14 x 1/8	14,32	11,0	110	32	9,0	11,14	350501006	132,65
Rd 16 x 1/8	16,32	12,0	110	32	9,0	13,14	350501007	138,95
Rd 18 x 1/8	18,32	14,0	125	32	11,0	15,14	350501008	133,30
Rd 20 x 1/8	20,32	16,0	140	32	12,0	17,14	350501009	166,30
Rd 22 x 1/8	22,32	18,0	140	32	14,5	19,14	350501010	215,80
Rd 24 x 1/8	24,32	18,0	160	34	14,5	21,14	350501011	260,00
Rd 26 x 1/8	26,32	20,0	160	36	16,0	23,14	350501012	304,20
Rd 28 x 1/8	28,32	20,0	160	36	16,0	25,14	350501013	326,32
Rd 30 x 1/8	30,32	22,0	180	36	18,0	27,14	350501014	343,16
Rd 32 x 1/8	32,82	25,0	180	36	20,0	29,14	350501015	458,95
Rd 34 x 1/8	34,32	28,0	200	36	22,0	31,14	350501016	521,05
Rd 36 x 1/8	36,32	28,0	200	36	22,0	33,14	350501017	525,26
Rd 38 x 1/8	38,32	28,0	200	38	22,0	35,14	350501018	608,42
Rd 40 x 1/6	40,42	32,0	200	50	24,0	36,19	350501019	718,95

RD	D	D1	H	D2	No.	€
Rd 10 x 1/10	10,25	38	14	9,84	351401001	325,50
Rd 11 x 1/10	11,25	38	14	10,84	351401002	325,50
Rd 12 x 1/10	12,25	38	14	11,84	351401003	325,50
Rd 14 x 1/8	14,32	45	18	13,82	351401004	367,50
Rd 16 x 1/8	16,32	45	18	15,82	351401005	367,50
Rd 18 x 1/8	18,32	45	18	17,82	351401006	367,50
Rd 20 x 1/8	20,32	55	22	19,82	351401007	504,00
Rd 22 x 1/8	22,32	55	22	21,82	351401008	504,00
Rd 24 x 1/8	24,32	55	22	23,82	351401009	504,00
Rd 26 x 1/8	26,32	65	25	25,82	351401010	632,10
Rd 28 x 1/8	28,32	65	25	27,82	351401011	632,10
Rd 30 x 1/8	30,32	65	25	29,82	351401012	632,10
Rd 32 x 1/8	32,82	65	25	31,82	351401013	632,10

**RMS**

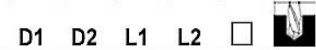

Machine Taps



**RMS**

Royal Microscopical Society DIN 58888

Royal Microscopical Society DIN 58888

W 0,8 x 36	20,35	16,0	80	18	12,0	19,45	360501001	on request
------------	-------	------	----	----	------	-------	-----------	------------

W 0,8 x 36	20,35	45	14	20,00	361401002	on request
------------	-------	----	----	-------	-----------	------------

JOGOS DE MACHOS E CAÇONETES HSS VG

# VG Valve thread

DIN 7756

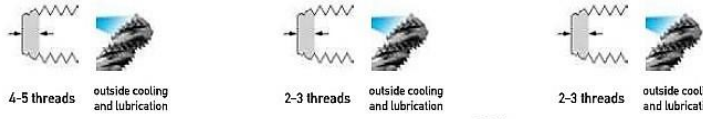
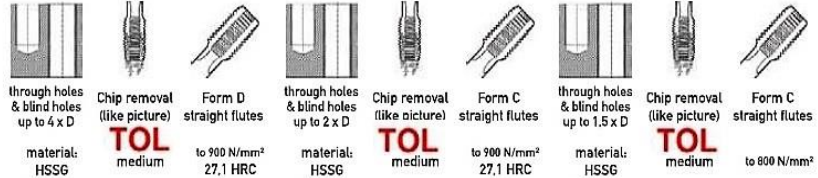

**Short Machine Taps**  
Form D for through holes and blind holes

**Hand Tap Sets**  
for general use

**Short Machine Taps**  
Form C for through holes and blind holes

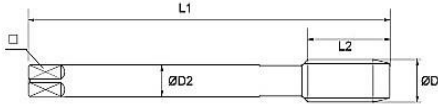

VG	D1	D2	L1	L2	□	No.	€	No.	€	No.	€
----	----	----	----	----	---	-----	---	-----	---	-----	---

DIN 2181											
VG 5 x 36	5,15	6,0	50	12	4,9	4,65	390101001	68,40	390301001	265,26	
VG 5,2 x 24	5,23	6,0	56	17	4,9	4,25	390101002	68,40	390301002	243,16	
VG 6 x 32	5,98	6,0	56	14	4,9	5,35	390101003	76,30	390301003	276,32	
VG 8 x 32	7,68	7,0	56	16	5,5	6,90	390101004	77,90	390301004	309,48	
VG 10 x 28	10,27	8,0	63	18	6,2	9,35	390101005	84,20	390301005	331,58	
VG 12 x 26	12,17	9,0	70	22	7,0	11,15	390101006	94,75	390301006	223,97	

DIN 374											
VG 5 x 36	5,15	6,0	70	12	4,9	4,65				390501001	75,40
VG 5,2 x 24	5,23	6,0	80	17	4,9	4,25				390501002	126,30
VG 6 x 32	5,98	7,0	80	14	5,5	5,35				390501003	144,70
VG 8 x 32	7,68	8,0	80	16	6,2	6,90				390501004	85,84
VG 10 x 28	10,27	8,0	90	18	6,2	9,35				390501005	170,00
VG 12 x 26	12,17	9,0	100	22	7,0	11,15				390501006	200,00

## JOGOS DE MACHOS E CAÇONETES HSS W

### W Tapered whitworth DIN 477 for screw sockets taper 3:25

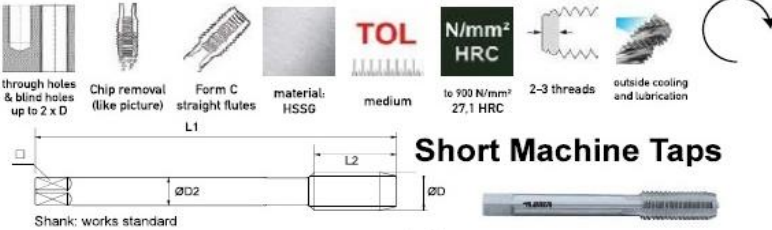

**Short Machine Taps**

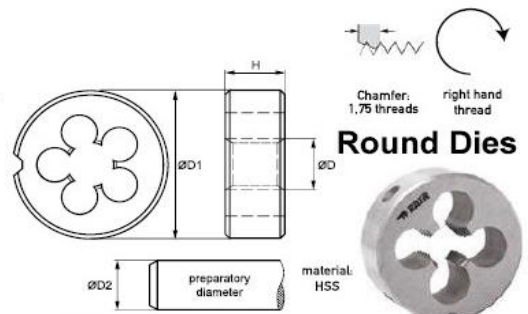

**Round Dies**

W	D1	D2	L1	L2	□	No.	€	
W 19,8 x 14 conical	19,80	16,0	90	32	12,0	14,70	300101001	158,13
W 28,8 x 14 conical	28,80	22,0	100	40	18,0	22,70	300101002	178,20
W 31,3 x 14 conical	31,30	22,0	110	40	18,0	25,20	300101003	204,93
W 21,8 x 14 cyl. - right	21,80	18,0	80	22	14,5	19,75	310101004	*
W 21,8 x 14 cyl. - left	21,80	18,0	80	22	14,5	19,75	310101005	*
W 24,32 x 14 cylindrical	24,32	18,0	90	22	14,5	22,25	310101006	*

W	D	D1	H	D2	No.	€
W 19,8 x 14 conical	19,80	45	25	17,34	301401001	405,83
W 28,8 x 14 conical	28,80	65	30	25,74	301401002	580,65
W 21,8 x 14 cyl. - right	21,80	55	16	21,58	311401003	274,58
W 21,8 x 14 cyl. - left	21,80	55	16	21,58	311401004	302,40
W 24,32 x 14 cylindrical	24,32	55	16	24,10	311401005	369,60

OUTRAS CONFIGURAÇÕES – FAVOR CONSULTAR

## MACHOS E CAÇONETES HSS CAMERA-TRIPÉ

### Camera Tripod DIN 4503



**Short Machine Taps**

**Hand Tap Sets**

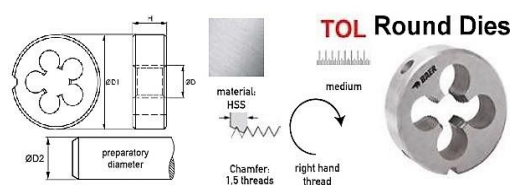
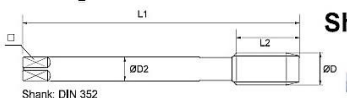

**TOL Round Dies**

Camera	D1	D2	L1	L2	□	No.	€	No.	€
Cam.-Tripod 1/4"	6,35	6,0	50	19	4,9	5,20	380101001	29,09	
Cam.-Tripod 3/8"	9,53	7,0	70	24	5,5	8,00	380101002	40,53	
C-Mount 1" x 32	25,40	18,0	130	45	14,0	23,75	380101003	387,45	
S-Mount 12 x 0,5	12,00	9,0	70	22	7,0	11,50		380301004	99,73

Camera	D	D1	H	D2	No.	€
Camera-Tripod 1/4"	6,35	20	7	6,22	381401001	37,59
Camera-Tripod 3/8"	9,53	20	7	9,37	381401002	50,40
C-Mount 1" x 32	25,40	55	16	25,25	381401003	271,43
S-Mount 12 x 0,5	12,00	38	10	11,92	381401004	100,11

OUTRAS CONFIGURAÇÕES – FAVOR CONSULTAR

ON REQUEST ANY OTHER EXECUTION