



CAÇONETES MACHOS TARRACHAS - UNF

CAÇONETES REDONDOS - UNF

HSS DIREITOS

HSS ESQUERDOS

HSSE - INOX

UNF

Unified fine thread
ANSI B1.1

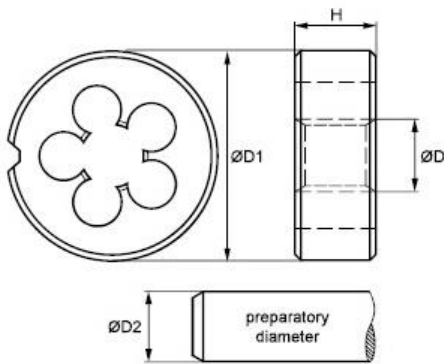

Round Dies

Round Dies
for general use



material:
HSS

2A

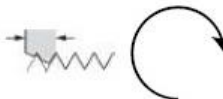

Chamfer:
1.5 threads

right hand
thread



Round Dies
for general use
Left Hand



material:
HSS

2A

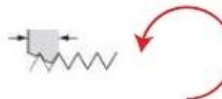

Chamfer:
1.5 threads

left hand
thread



Round Dies
for stainless steels



material:
HSSE

2A

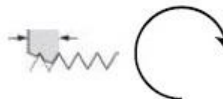

Chamfer:
2 threads

right hand
thread



UNF

	D	D1	H	D2	No.	€	No.	€	No.	€
UNF NR. 0 x 80	1,52	16	5	1,47	151401001	20,00				
UNF NR. 1 x 72	1,85	16	5	1,79	151401002	20,00				
UNF NR. 2 x 64	2,18	16	5	2,12	151401003	15,95				
UNF NR. 3 x 56	2,52	16	5	2,44	151401004	15,95				
UNF NR. 4 x 48	2,85	20	5	2,77	151401005	13,20				
UNF NR. 5 x 44	3,18	20	5	3,10	151401006	13,20				
UNF NR. 6 x 40	3,51	20	5	3,42	151401007	12,30				
UNF NR. 8 x 36	4,17	20	7	4,08	151401008	12,30				
UNF NR. 10 x 32	4,83	20	7	4,73	151401009	12,30	151402001	22,27	151405001	75,39
UNF NR. 12 x 28	5,49	20	7	5,38	151401010	12,30				
UNF 1/4 x 28	6,35	20	7	6,24	151401011	11,69	151402002	18,04	151405002	90,81
UNF 5/16 x 24	7,94	25	9	7,82	151401012	13,36	151402003	21,05	151405003	94,15
UNF 3/8 x 24	9,53	30	11	9,41	151401013	14,82	151402004	25,62	151405004	116,11
UNF 7/16 x 20	11,11	30	11	10,98	151401014	17,15	151402005	25,62	151405005	111,97
UNF 1/2 x 20	12,70	38	10	12,56	151401015	19,27	151402006	40,09		
UNF 9/16 x 18	14,29	38	10	14,14	151401016	23,84	151402007	40,09		
UNF 5/8 x 18	15,88	45	14	15,73	151401017	26,06	151402008	51,24		
UNF 3/4 x 16	19,05	45	14	18,89	151401018	26,06	151402009	51,24		
UNF 7/8 x 14	22,23	55	16	22,05	151401019	44,54	151402010	74,62		
UNF 1" x 12	25,40	55	16	25,21	151401020	44,54	151402011	74,62		
UNF 1" x 14	25,40	55	16	25,23	151401021	44,54				
UNF 1,1/8 x 12	28,58	65	18	28,38	151401022	67,39				
UNF 1,1/4 x 12	31,75	65	18	31,55	151401023	67,39				
UNF 1,3/8 x 12	34,93	65	18	34,73	151401024	67,39				
UNF 1,1/2 x 12	38,10	65	18	37,90	151401025	67,39				
UNF 1,1/2 x 12	38,10	75	20	37,90	151401026	120,29				

UNF

Unified fine thread
ANSI B1.1

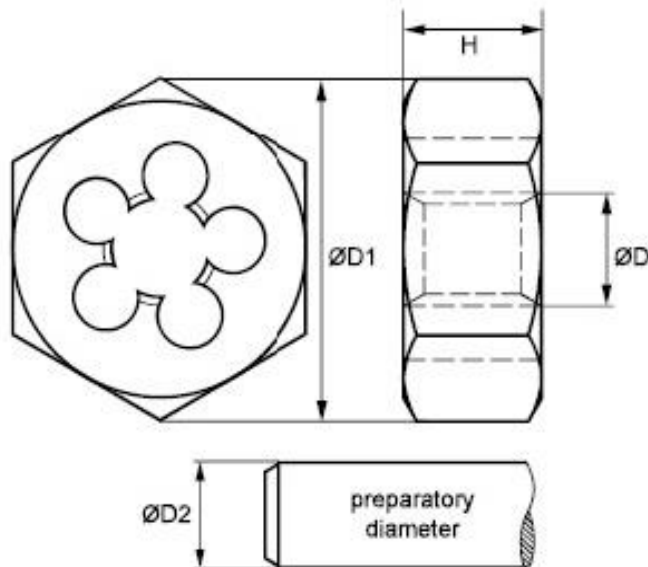

Hexagon Die Nuts

Hexagon Die Nuts
for general use



material:
HSS



2A



Chamfer:
1.5 threads

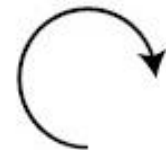

right hand
thread



UNF

	D	D1	H	D2	No.	€
UNF 1/4 x 28	6,35	19	7	6,24	151501001	14,48
UNF 5/16 x 24	7,94	22	9	7,82	151501002	15,03
UNF 3/8 x 24	9,53	27	11	9,41	151501003	18,16
UNF 7/16 x 20	11,11	27	11	10,98	151501004	18,16
UNF 1/2 x 20	12,70	36	10	12,56	151501005	22,27
UNF 9/16 x 18	14,29	36	10	14,14	151501006	22,27
UNF 5/8 x 18	15,88	41	14	15,73	151501007	30,41
UNF 3/4 x 16	19,05	41	14	18,89	151501008	30,41
UNF 7/8 x 14	22,23	50	16	22,05	151501009	63,16
UNF 1" x 12	25,40	50	16	25,21	151501010	63,16
UNF 1,1/8 x 12	28,58	60	18	28,38	151501011	95,79
UNF 1,1/4 x 12	31,75	60	18	31,55	151501012	95,79
UNF 1,3/8 x 12	34,93	60	18	34,73	151501013	95,79
UNF 1,1/2 x 12	38,10	70	20	37,90	151501014	114,72

Thread Cutting Kits with Taps, Dies and Tools

UNF

Unified fine thread
ANSI B1.1

Hand-Tap Sets, Round Dies and Tools Sets
(example picture)



Set UNF 1/4" - 1/2"		€/Set
HSSG Hand Tap Sets & HSS Round Dies & Tools		
HSSG Hand Tap Sets (2 parts)	UNF 1/4 x 28 UNF 5/16 x 24 UNF 3/8 x 24 UNF 7/16 x 20 UNF 1/2 x 20	255,00 € Item No.: 264806004
HSS Round Dies	UNF 1/4 x 28 UNF 5/16 x 24 UNF 3/8 x 24 UNF 7/16 x 20 UNF 1/2 x 20	
adjustable Tap Wrenches - zinc die cast	M 1-10 1/16-3/8 G 1/8 & M 4-12 5/32-1/2 G 1/8	
Die Stocks - zinc die cast	20 x 7 25 x 9 30 x 11 38 x 10	
Screw extractor		

Set UNF 1/4" - 3/4"		€/Set
HSSG Hand Tap Sets & HSS Round Dies & Tools		
HSSG Hand Tap Sets (2 parts)	UNF 1/4 x 28 UNF 5/16 x 24 UNF 3/8 x 24 UNF 7/16 x 20 UNF 1/2 x 20 UNF 5/8 x 18 UNF 3/4 x 16	427,00 € Item No.: 264806104
HSS Round Dies	UNF 1/4 x 28 UNF 5/16 x 24 UNF 3/8 x 24 UNF 7/16 x 20 UNF 1/2 x 20 UNF 5/8 x 18 UNF 3/4 x 16	
adjustable Tap Wrenches - zinc die cast	M 1-10 1/16-3/8 G 1/8 & M 5-20 7/32-3/4" G 1/8-1/2	
Die Stocks - zinc die cast	20 x 7 25 x 9 30 x 11 38 x 10 45 x 14	
Screw extractor		

Set UNF 1/4" - 1"		€/Set
HSSG Hand Tap Sets & HSS Round Dies & Tools		
HSSG Hand Tap Sets (2 parts)	UNF 1/4 x 28 UNF 5/16 x 24 UNF 3/8 x 24 UNF 7/16 x 20 UNF 1/2 x 20 UNF 5/8 x 18 UNF 3/4 x 16 UNF 7/8 x 14 UNF 1" x 12	644,00 € Item No.: 264806304
HSS Round Dies	UNF 1/4 x 28 UNF 5/16 x 24 UNF 3/8 x 24 UNF 7/16 x 20 UNF 1/2 x 20 UNF 5/8 x 18 UNF 3/4 x 16 UNF 7/8 x 14 UNF 1" x 12	
adjustable Tap Wrenches - zinc die cast	M 1-10 1/16-3/8 G 1/8 & M 11-27 7/16-1" G 1/4-3/4	
Die Stocks - zinc die cast	20 x 7 25 x 9 30 x 11 38 x 10 45 x 14 55 x 16	
Screw extractor		

Set UNC & UNF 1/4" - 3/4"		€/Set
HSSG Hand Tap Sets & HSS Round Dies & Tools		
HSSG Hand Tap Sets (3 parts) UNC	UNC 1/4 UNC 5/16 UNC 3/8 UNC 7/16 UNC 1/2 UNC 5/8 UNC 3/4	777,00 € Item No.: 264806203
HSSG Hand Tap Sets (2 parts) UNF	UNF 1/4 UNF 5/16 UNF 3/8 UNF 7/16 UNF 1/2 UNF 5/8 UNF 3/4	
HSS Round Dies UNC	UNC 1/4 UNC 5/16 UNC 3/8 UNC 7/16 UNC 1/2 UNC 5/8 UNC 3/4	
HSS Round Dies UNF	UNF 1/4 UNF 5/16 UNF 3/8 UNF 7/16 UNF 1/2 UNF 5/8 UNF 3/4	
adjustable Tap Wrenches - zinc die cast	M 1-10 1/16-3/8 G 1/8 & M 5-20 7/32-3/4" G 1/8-1/2	
Die Stocks - zinc die cast	20 x 7 25 x 9 30 x 11 38 x 14 45 x 18	
Screw extractor		



Thread Cutting Kits with Taps and Dies

Unified fine thread
ANSI B1.1

(example picture)

Short Machine Taps und Round Dies Sets UNF 1/4" - 1/2"

Set UNF 1/4" - 1/2"		€/Set
HSSG Short Machine Taps & Drill bits for core holes		
HSS Round Dies		
HSSG Short Machine Tap Form D for through hole & blind hole (up to 4 x D)	UNF 1/4 x 28 UNF 5/16 x 24 UNF 3/8 x 24 UNF 7/16 x 20 UNF 1/2 x 20	172,73 € Item No.: BES3
HSSG Drill bits for core holes	5,5 mm 6,9 mm 8,5 mm 9,9 mm 11,5 mm	
HSS Round Dies	UNF 1/4 x 28 UNF 5/16 x 24 UNF 3/8 x 24 UNF 7/16 x 20 UNF 1/2 x 20	

UNF

Unified fine thread
ANSI B1.1

Efficient internal thread cutting.
The short structural type makes that tap usable by hand. The Short-Machine-Tap is also usable by machine.

A Hand-Tap-Set includes 2 taps:
Taper Tap
Finish Tap

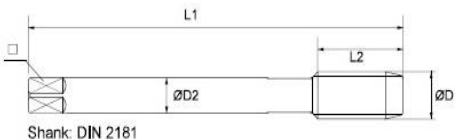

Short Machine Taps

Form D for through holes and blind holes

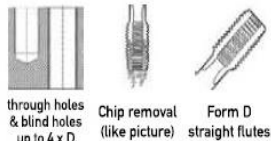

through holes & blind holes up to 4 x D
Chip removal (like picture)
Form D straight flutes
material: HSSG 2B to 900 N/mm² 27,1 HRC

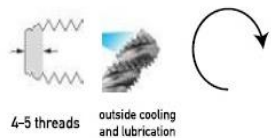

Hand Tap Sets for general use

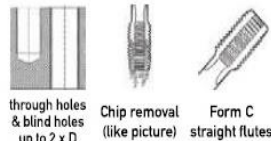

through holes & blind holes up to 2 x D
Chip removal (like picture)
Form C straight flutes
material: HSSG 2B to 900 N/mm² 27,1 HRC

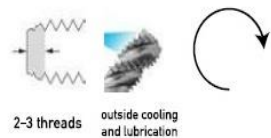

Hand Tap Sets for general use

Left Hand

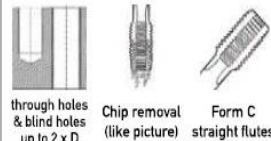

through holes & blind holes up to 2 x D
Chip removal (like picture)
Form C straight flutes
material: HSSG 2B to 900 N/mm² 27,1 HRC



UNF

	D1	D2	L1	L2	□		No.	€	No.	€	No.	€
UNF No 0 x 80	1,52	2,5	28	8	2,1	1,30			150301001	13,36		
UNF No 1 x 72	1,85	2,8	32	9	2,1	1,60			150301002	13,36		
UNF No 2 x 64	2,18	2,8	32	10	2,1	1,90			150301003	13,36		
UNF No 3 x 56	2,52	2,8	32	10	2,1	2,10			150301004	13,36		
UNF No 4 x 48	2,85	3,5	36	11	2,7	2,40			150301005	11,14		
UNF No 5 x 44	3,18	3,5	36	11	2,7	2,70			150301006	9,35		
UNF No 6 x 40	3,51	4,5	40	12	3,4	3,00			150301007	9,35		
UNF No 8 x 36	4,17	4,5	40	12	3,4	3,50			150301008	9,35		
UNF No 10 x 32	4,83	6,0	45	14	4,9	4,10			150301009	9,35	150302001	24,28
UNF No 12 x 28	5,49	6,0	50	14	4,9	4,70			150301010	9,35		
UNF 1/4 x 28	6,35	6,0	50	18	4,9	5,50	150101001	4,67	150301011	9,36	150302002	15,37
UNF 5/16 x 24	7,94	6,0	56	22	4,9	6,90	150101002	5,24	150301012	10,47	150302003	16,04
UNF 3/8 x 24	9,53	7,0	63	22	5,5	8,50	150101003	5,79	150301013	11,58	150302004	18,71
UNF 7/16 x 20	11,11	8,0	63	22	6,2	9,90	150101004	7,35	150301014	14,70	150302005	22,94
UNF 1/2 x 20	12,70	9,0	75	24	7,0	11,50	150101005	8,91	150301015	17,82	150302006	27,40
UNF 9/16 x 18	14,29	11,0	80	28	9,0	12,90	150101006	11,69	150301016	23,39	150302007	35,64
UNF 5/8 x 18	15,88	12,0	80	28	9,0	14,50	150101007	13,14	150301017	26,29	150302008	40,54
UNF 3/4 x 16	19,05	14,0	95	32	11,0	17,50	150101008	17,60	150301018	35,19	150302009	54,13
UNF 7/8 x 14	22,23	18,0	100	36	14,5	20,25	150101009	23,39	150301019	46,78	150302010	67,50
UNF 1" x 12	25,40	18,0	110	40	14,5	23,25	150101010	26,95	150301020	53,91	150302011	81,08
UNF 1" x 14	25,40	18,0	110	40	14,5	23,30			150301021	58,37		
UNF 1,1/8 x 12	28,58	22,0	110	50	18,0	26,50			150301022	83,09		
UNF 1,1/4 x 12	31,75	22,0	132	56	18,0	29,50			150301023	93,56		
UNF 1,3/8 x 12	34,93	28,0	132	56	22,0	32,50			150301024	121,62		
UNF 1,1/2 x 12	38,10	32,0	150	63	24,0	36,00			150301025	140,33		

Machine Taps - Form B for through holes

UNF Unified fine thread ANSI B1.1

Machine Tap for general use

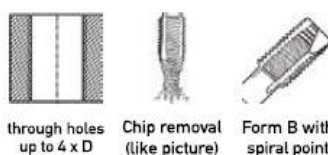

through holes up to 4 x D Chip removal (like picture) Form B with spiral point



material: HSSE 2B to 900 N/mm² 27.1 HRC



4-5 threads outside cooling and lubrication

Machine Tap for stainless steels

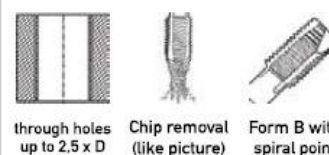

through holes up to 2.5 x D Chip removal (like picture) Form B with spiral point



material: HSSE-TiAlN 2B to 1300 N/mm² 41 HRC



4-5 threads outside cooling and lubrication

Tap for machine use in through hole. The spiral point pushes the chips ahead.

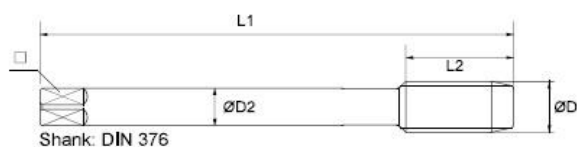
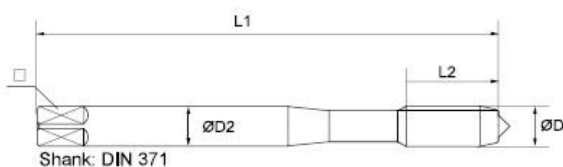

UNF

	D1	D2	L1	L2	□		No.	€	No.	€
UNF No 3 x 56	2,52	2,8	50	9	2,1	2,10			150405001	47,78
UNF No 4 x 48	2,85	3,5	50	10	2,7	2,40	150401001	9,58	150405002	46,75
UNF No 5 x 44	3,18	3,5	56	11	2,7	2,70	150401002	9,58	150405003	49,22
UNF No 6 x 40	3,51	4,0	56	12	3,0	3,00	150401003	9,58	150405004	49,22
UNF No 8 x 36	4,17	4,5	63	13	3,4	3,50	150401004	9,58	150405005	50,26
UNF No 10 x 32	4,83	6,0	70	15	4,9	4,10	150401005	9,58	150405006	56,88
UNF No 12 x 28	5,49	6,0	70	16	4,9	4,70	150401006	9,58	150405007	50,07
UNF 1/4 x 28	6,35	7,0	80	17	5,5	5,50	150401007	9,58	150405008	50,07
UNF 5/16 x 24	7,94	8,0	90	17	6,2	6,90	150401008	12,14	150405009	54,30
UNF 3/8 x 24	9,53	9,0	100	18	7,0	8,50	150401009	13,58	150405010	62,57
UNF 7/16 x 20	11,11	8,0	100	22	6,2	9,90	150401010	16,15	150405011	75,00
UNF 1/2 x 20	12,70	9,0	100	22	7,0	11,50	150401011	16,15	150405012	75,00
UNF 9/16 x 18	14,29	11,0	100	22	9,0	12,90	150401012	24,62	150405013	83,63
UNF 5/8 x 18	15,88	12,0	100	22	9,0	14,50	150401013	24,62	150405014	104,94
UNF 3/4 x 16	19,05	14,0	110	25	11,0	17,50	150401014	47,89	150405015	148,64
UNF 7/8 x 14	22,23	18,0	140	26	14,5	20,25	150401015	57,92	150405016	170,80
UNF 1" x 12	25,40	20,0	150	28	16,0	23,25	150401016	65,71	150405017	217,79
UNF 1" x 14	25,40	20,0	150	28	16,0	23,30	150401017	65,71		
UNF 1.1/4 x 12	31,75	22,0	150	30	18,0	29,50	150401018	91,88		
UNF 1.1/2 x 12	38,10	32,0	170	33	24,0	36,00	150401019	191,56		

Machine Taps - Form C (with spiral flutes) for blind holes

UNF

Unified fine thread
ANSI B1.1

Tap for machine use in blind holes.
The fast spiral flutes provide good chip removal from the blind hole.

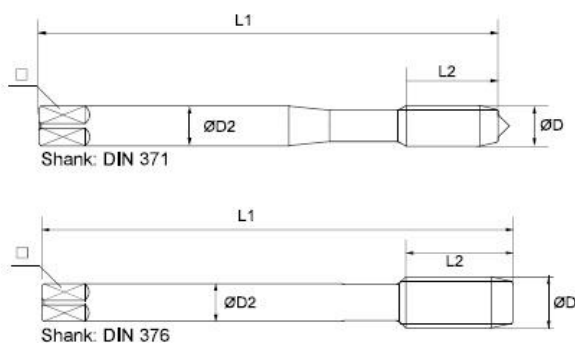

Machine Tap for general use

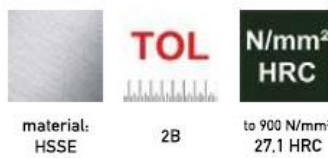
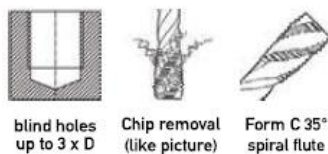

Machine Tap for stainless steels

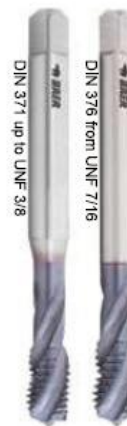
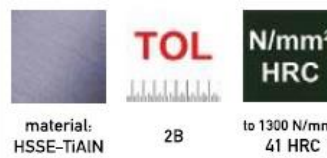
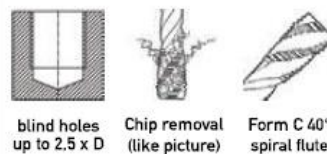

UNF

	D1	D2	L1	L2	□		No.	€	No.	€
UNF No 3 x 56	2,52	2,8	50	6	2,1	2,10			150605001	50,05
UNF No 4 x 48	2,85	3,5	50	6	2,7	2,40	150601001	11,92	150605002	47,78
UNF No 5 x 44	3,18	3,5	56	7	2,7	2,70	150601002	11,92	150605003	46,75
UNF No 6 x 40	3,51	4,0	56	7	3,0	3,00	150601003	11,92	150605004	49,22
UNF No 8 x 36	4,17	4,5	63	8	3,4	3,50	150601004	11,92	150605005	49,22
UNF No 10 x 32	4,83	6,0	70	10	4,9	4,10	150601005	11,92	150605006	50,26
UNF No 12 x 28	5,49	6,0	70	10	4,9	4,70	150601006	11,92	150605007	54,36
UNF 1/4 x 28	6,35	7,0	80	10	5,5	5,50	150601007	11,92	150605008	53,64
UNF 5/16 x 24	7,94	8,0	90	10	6,2	6,90	150601008	14,93	150605009	58,01
UNF 3/8 x 24	9,53	9,0	100	10	7,0	8,50	150601009	16,37	150605010	66,73
UNF 7/16 x 20	11,11	8,0	100	13	6,2	9,90	150601010	20,16	150605011	79,81
UNF 1/2 x 20	12,70	9,0	100	13	7,0	11,50	150601011	20,16	150605012	79,81
UNF 9/16 x 18	14,29	11,0	100	15	9,0	12,90	150601012	29,73	150605013	88,86
UNF 5/8 x 18	15,88	12,0	100	15	9,0	14,50	150601013	29,73	150605014	111,24
UNF 3/4 x 16	19,05	14,0	110	17	11,0	17,50	150601014	59,26	150605015	157,13
UNF 7/8 x 14	22,23	18,0	140	17	14,5	20,25	150601015	72,39	150605016	180,45
UNF 1" x 12	25,40	20,0	150	20	16,0	23,25	150601016	81,31	150605017	229,76
UNF 1" x 14	25,40	20,0	150	20	16,0	23,30	150601017	90,02		
UNF 1.1/4 x 12	31,75	22,0	150	22	18,0	29,50	150601018	103,58		
UNF 1.1/2 x 12	38,10	32,0	170	25	24,0	36,00	150601019	226,09		

UNiForm Machine Forming Taps

1/4" Combined-Bit-Taps

UNF

Unified fine thread
ANSI B1.1

Machine Forming Taps have following advantages:

- No chips
- Up to 20 times longer lifetime (compared to taps)
- Same forming tap for through and blind hole
- Wide range of materials can be processed
- Intersection of the thread is impossible
- Very high trueness
- Increased strength of the thread
- Higher surface quality
- Much higher cutting speed

Machine Forming Taps for universal use

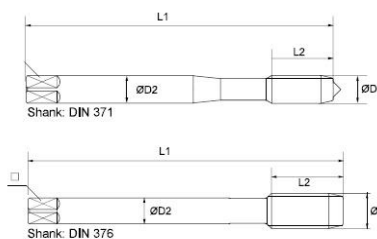
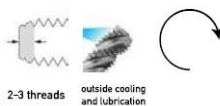
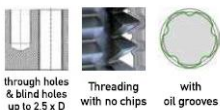

UNF

	D1	D2	L1	L2	□	🔧	No.	€
UNF No 2 x 64	2,18	2,8	45	7	2,1	2,02	151101001	*
UNF No 4 x 48	2,85	3,5	56	11	2,7	2,62	151101002	*
UNF No 6 x 40	3,51	4,0	56	12	3,0	3,22	151101003	*
UNF No 8 x 36	4,17	4,5	63	13	3,4	3,85	151101004	*
UNF No 10 x 32	4,83	6,0	70	15	4,9	4,45	151101005	*
UNF 1/4 x 28	6,35	7,0	80	17	5,5	5,95	151101006	*
UNF 5/16 x 24	7,94	8,0	90	17	6,2	7,45	151101007	*
UNF 3/8 x 24	9,53	10,0	90	18	8,0	9,05	151101008	*
UNF 7/16 x 20	11,11	8,0	100	22	6,2	10,55	151101009	*
UNF 1/2 x 20	12,70	9,0	100	22	7,0	12,15	151101010	*
UNF 5/8 x 18	15,88	12,0	100	22	9,0	15,25	151101011	*
UNF 3/4 x 16	19,05	14,0	110	25	11,0	18,35	151101012	*

* on request

UNF

Unified fine thread
ANSI B1.1

Efficient internal thread cutting with battery-powered screwdriver (min. 7,5 Volt). Core hole drilling and thread tapping in one fluent process.

Application:
non abrasive material up to 600 N/mm² unalloyed and low alloyed steel

Kombi-Bit-Taps for through holes

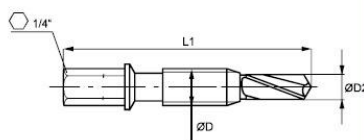
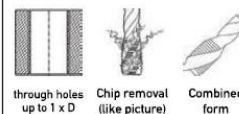

UNF

	D1	D2	L1	🔧	No.	€
UNF No 4 x 48	2,85	2,4	36	1/4"	151301001	*
UNF No 5 x 44	3,18	2,7	36	1/4"	151301002	*
UNF No 6 x 40	3,51	3,0	39	1/4"	151301003	*
UNF No 8 x 36	4,17	3,5	39	1/4"	151301004	*
UNF No 10 x 32	4,83	4,1	41	1/4"	151301005	*
UNF No 12 x 28	5,49	4,7	41	1/4"	151301006	*
UNF 1/4 x 28	6,35	5,5	44	1/4"	151301007	*
UNF 5/16 x 24	7,94	6,9	50	1/4"	151301008	*
UNF 3/8 x 24	9,53	8,5	59	1/4"	151301009	*

* on request