



CAÇONETES REDONDOS - UNC

HSS DIREITOS

HSS ESQUERDOS

HSSE - INOX

UNC Round Dies

Unified coarse thread
ANSI B1.1

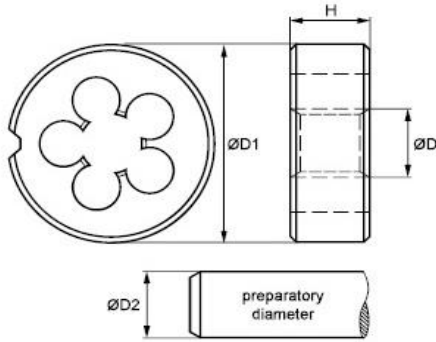

Round Dies
for general use



material: HSS 2A

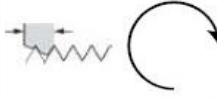

Chamfer: 1.5 threads
right hand thread



Round Dies
for general use
Left Hand



material: HSS 2A

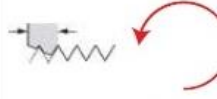

Chamfer: 1.5 threads
left hand thread



Round Dies
for stainless steels



material: HSSE 2A

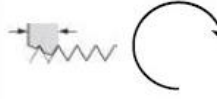

Chamfer: 2 threads
right hand thread



UNC	D	D1	H	D2	No.	€	No.	€	No.	€
UNC No 1 x 64	1,85	16	5	1,79	141401001	15,95				
UNC No 2 x 56	2,18	16	5	2,12	141401002	15,95				
UNC No 3 x 48	2,52	16	5	2,44	141401003	15,95				
UNC No 4 x 40	2,85	20	5	2,76	141401004	13,10			141405001	106,22
UNC No 5 x 40	3,18	20	5	3,09	141401005	12,30				
UNC No 6 x 32	3,51	20	7	3,41	141401006	12,30	141402001	22,27	141405002	90,45
UNC No 8 x 32	4,17	20	7	4,07	141401007	12,30	141402002	22,27	141405003	81,75
UNC No 10 x 24	4,83	20	7	4,71	141401008	12,30	141402003	22,27		
UNC No 12 x 24	5,49	20	7	5,37	141401009	12,30				
UNC 1/4 x 20	6,35	20	7	6,22	141401010	11,70	141402004	18,04	141405004	75,32
UNC 5/16 x 18	7,94	25	9	7,80	141401011	13,36	141402005	21,05	141405005	107,18
UNC 3/8 x 16	9,53	30	11	9,37	141401012	14,82	141402006	25,62	141405006	112,98
UNC 7/16 x 14	11,11	30	11	10,95	141401013	17,15	141402007	25,62		
UNC 1/2 x 13	12,70	38	14	12,52	141401014	19,27	141402008	40,09		
UNC 9/16 x 12	14,29	38	14	14,10	141401015	23,84	141402009	40,09		
UNC 5/8 x 11	15,88	45	18	15,68	141401016	26,06	141402010	51,24		
UNC 3/4 x 10	19,05	45	18	18,84	141401017	26,06	141402011	51,24		
UNC 7/8 x 9	22,23	55	22	22,00	141401018	44,54	141402012	74,62		
UNC 1" x 8	25,40	55	22	25,16	141401019	44,54	141402013	74,62		
UNC 1.1/8 x 7	28,58	65	25	28,31	141401020	67,39				
UNC 1.1/4 x 7	31,75	65	25	31,49	141401021	67,39				
UNC 1.3/8 x 6	34,93	65	25	34,63	141401022	67,39				
UNC 1.1/2 x 6	38,10	65	25	37,80	141401023	67,39				
UNC 1.1/2 x 6	38,10	75	30	37,80	141401024	120,29				
UNC 1.5/8 x 5	41,28	75	30	40,95	141401025	120,29				
UNC 1.3/4 x 5	44,45	90	36	44,12	141401026	183,77				
UNC 1.7/8 x 4,5	47,63	90	36	47,30	141401027	183,77				
UNC 2" x 4,5	50,80	90	36	50,45	141401028	183,77				

UNC

Unified coarse thread
ANSI B1.1

Hexagon Die Nuts

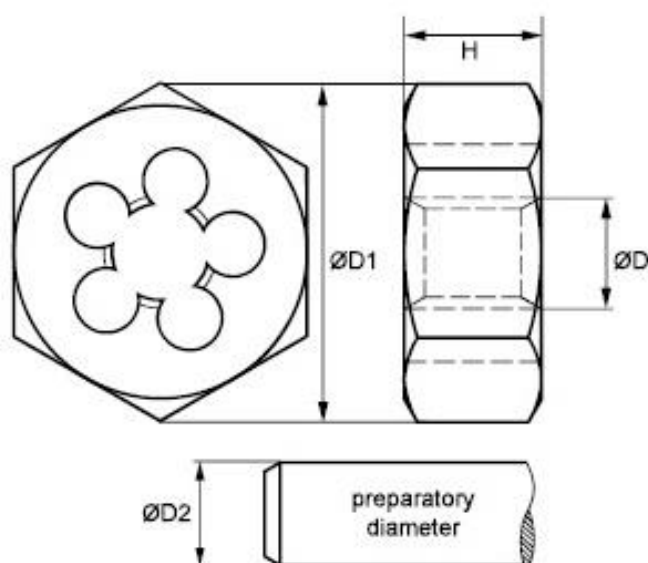

Hexagon Die Nuts for general use



material:
HSS

TOL



2A

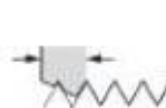

Chamfer:
1,5 threads



right hand
thread



UNC

	D	D1	H	D2	No.	€
UNC 1/4 x 20	6,35	19	7	6,22	141501001	14,48
UNC 5/16 x 18	7,94	22	9	7,80	141501002	15,03
UNC 3/8 x 16	9,53	27	11	9,37	141501003	18,16
UNC 7/16 x 14	11,11	27	11	10,95	141501004	18,16
UNC 1/2 x 13	12,70	36	14	12,52	141501005	22,27
UNC 9/16 x 12	14,29	36	14	14,10	141501006	22,27
UNC 5/8 x 11	15,88	41	18	15,68	141501007	30,41
UNC 3/4 x 10	19,05	41	18	18,84	141501008	30,41
UNC 7/8 x 9	22,23	50	22	22,00	141501009	63,16
UNC 1" x 8	25,40	50	22	25,16	141501010	63,16
UNC 1.1/8 x 7	28,58	60	25	28,31	141501011	95,79
UNC 1.1/4 x 7	31,75	60	25	31,49	141501012	95,79
UNC 1.3/8 x 6	34,93	60	25	34,63	141501013	95,79
UNC 1.1/2 x 6	38,10	70	30	37,80	141501014	101,83

UNC Unified coarse thread
ANSI B1.1

Hand-Tap Sets, Round Dies and Tools Sets
(example picture)



Set UNC 1/4" - 1/2"		€/Set
HSSG Hand Tap Sets & HSS Round Dies & Tools		
HSSG Hand Tap Sets (3 parts)	UNC 1/4 x 20 UNC 5/16 x 18 UNC 3/8 x 16 UNC 7/16 x 14 UNC 1/2 x 13	276,00 € Item No.: 264805003
HSS Round Dies	UNC 1/4 x 20 UNC 5/16 x 18 UNC 3/8 x 16 UNC 7/16 x 14 UNC 1/2 x 13	
adjustable Tap Wrenches - zinc die cast	M 1-10 1/16-3/8 G 1/8 & M 4-12 5/32-1/2 G 1/8	
Die Stocks - zinc die cast	20 x 7 25 x 9 30 x 11 38 x 14	
Screw extractor		

Set UNC 1/4" - 3/4"		€/Set
HSSG Hand Tap Sets & HSS Round Dies & Tools		
HSSG Hand Tap Sets (3 parts)	UNC 1/4 x 20 UNC 5/16 x 18 UNC 3/8 x 16 UNC 7/16 x 14 UNC 1/2 x 13 UNC 5/8 x 11 UNC 3/4 x 10	485,00 € Item No.: 264805103
HSS Round Dies	UNC 1/4 x 20 UNC 5/16 x 18 UNC 3/8 x 16 UNC 7/16 x 14 UNC 1/2 x 13 UNC 5/8 x 11 UNC 3/4 x 10	
adjustable Tap Wrenches - zinc die cast	M 1-10 1/16-3/8 G 1/8 & M 5-20 7/32-3/4 G 1/8-1/2	
Die Stocks - zinc die cast	20 x 7 25 x 9 30 x 11 38 x 14 45 x 18	
Screw extractor		

Set UNC 1/4" - 1"		€/Set
HSSG Hand Tap Sets & HSS Round Dies & Tools		
HSSG Hand Tap Sets (3 parts)	UNC 1/4 x 20 UNC 5/16 x 18 UNC 3/8 x 16 UNC 7/16 x 14 UNC 1/2 x 13 UNC 5/8 x 11 UNC 3/4 x 10 UNC 7/8 x 9 UNC 1" x 8	725,00 € Item No.: 264805303
HSS Round Dies	UNC 1/4 x 20 UNC 5/16 x 18 UNC 3/8 x 16 UNC 7/16 x 14 UNC 1/2 x 13 UNC 5/8 x 11 UNC 3/4 x 10 UNC 7/8 x 9 UNC 1" x 8	
adjustable Tap Wrenches - zinc die cast	M 1-10 1/16-3/8 G 1/8 & M 11-27 7/16-1" G 1/4-3/4	
Die Stocks - zinc die cast	20 x 7 25 x 9 30 x 11 38 x 14 45 x 18 55 x 22	
Screw extractor		

Set UNC 1/4" - 1.1/2"		€/Set
HSSG Hand Tap Sets & HSS Round Dies & Tools		
HSSG Hand Tap Sets (3 parts)	UNC 1/4 x 20 UNC 5/16 x 18 UNC 3/8 x 16 UNC 7/16 x 14 UNC 1/2 x 13 UNC 5/8 x 11 UNC 3/4 x 10 UNC 7/8 x 9 UNC 1" x 8 UNC 1.1/8" x 7 UNC 1.1/4" x 7 UNC 1.1/2" x 6	1836,00 € Item No.: 264805403
HSS Round Dies	UNC 1/4 x 20 UNC 5/16 x 18 UNC 3/8 x 16 UNC 7/16 x 14 UNC 1/2 x 13 UNC 5/8 x 11 UNC 3/4 x 10 UNC 7/8 x 9 UNC 1" x 8 UNC 1.1/8" x 7 UNC 1.1/4" x 7 UNC 1.1/2" x 6	
adjustable Tap Wrenches - zinc die cast	M 1-10 1/16-3/8 G 1/8 & M 5-20 7/32-3/4 G 1/8-1/2 & M 13-32 1/2 - 1.1/4" G 1/4-1"	
Die Stocks - zinc die cast	20 x 7 25 x 9 30 x 11 38 x 14 45 x 18 55 x 22 65 x 25	
Screw extractor		

Set UNC & UNF 1/4" - 3/4"		€/Set
HSSG Hand Tap Sets & HSS Round Dies & Tools		
HSSG Hand Tap Sets (3 parts) UNC	UNC 1/4 UNC 5/16 UNC 3/8 UNC 7/16 UNC 1/2 UNC 5/8 UNC 3/4	777,00 € Item No.: 264806203
HSSG Hand Tap Sets (2 parts) UNF	UNF 1/4 UNF 5/16 UNF 3/8 UNF 7/16 UNF 1/2 UNF 5/8 UNF 3/4	
HSS Round Dies UNC	UNC 1/4 UNC 5/16 UNC 3/8 UNC 7/16 UNC 1/2 UNC 5/8 UNC 3/4	
HSS Round Dies UNF	UNF 1/4 UNF 5/16 UNF 3/8 UNF 7/16 UNF 1/2 UNF 5/8 UNF 3/4	
adjustable Tap Wrenches - zinc die cast	M 1-10 1/16-3/8 G 1/8 & M 5-20 7/32-3/4" G 1/8-1/2	
Die Stocks - zinc die cast	20 x 7 25 x 9 30 x 11 38 x 14 45 x 18	
Screw extractor		

Short Machine Taps und Round Dies Sets UNC 1/4" - 1/2"

Unified coarse thread
ANSI B1.1



Thread Cutting Kits with Taps and Dies

Set UNC 1/4" - 1/2"		€/Set
HSSG Short Machine Taps & Drill bits for core holes		
HSSG Short Machine Tap Form D for through hole & blind hole (up to 4 x D)	UNC 1/4 x 20 UNC 5/16 x 18 UNC 3/8 x 16 UNC 7/16 x 14 UNC 1/2 x 13	168,21 € Item No.: BES2
HSSG Drill bits for core holes	5,2 mm 6,6 mm 8,0 mm 9,4 mm 10,8 mm	
HSS Round Dies	UNC 1/4 x 20 UNC 5/16 x 18 UNC 3/8 x 16 UNC 7/16 x 14 UNC 1/2 x 13	

UNC

Unified coarse thread
ANSI B1.1

Efficient internal thread cutting.
The short structural type makes that tap usable by hand. The Short-Machine-Tap is also usable by machine.

A Hand-Tap-Set includes 3 taps:

- Taper Tap
- Intermediate Tap
- Finish Tap

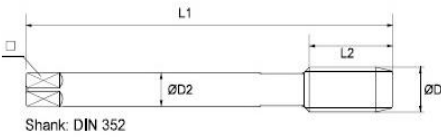

Short Machine Taps

Form D for through holes and blind holes

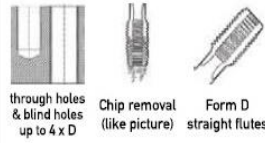

material: HSSG 2B to 900 N/mm² 27.1 HRC

TOL **N/mm² HRC**

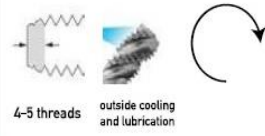

Hand Tap Sets

for general use

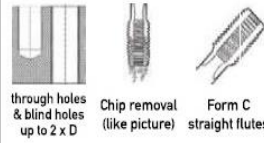

material: HSSG 2B to 900 N/mm² 27.1 HRC

TOL **N/mm² HRC**

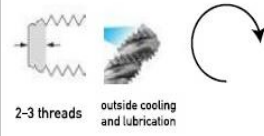

Hand Tap Sets

for general use

Left Hand

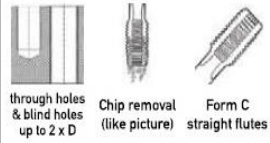

material: HSSG 2B to 900 N/mm² 27.1 HRC

TOL **N/mm² HRC**

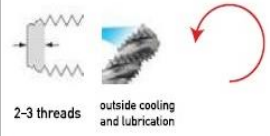

UNC	D1	D2	L1	L2	□	✂	No.	€	No.	€	No.	€
UNC No 1 x 64	1,85	2,5	32	10	2,1	1,50			140301001	19,95		
UNC No 2 x 56	2,18	2,8	36	11	2,1	1,80			140301002	19,95		
UNC No 3 x 48	2,52	2,8	36	11	2,1	2,10			140301003	19,95		
UNC No 4 x 40	2,85	3,5	40	12	2,7	2,30			140301004	16,65		
UNC No 5 x 40	3,18	3,5	40	12	2,7	2,60			140301005	14,00		
UNC No 6 x 32	3,51	4,0	45	14	3,0	2,85			140301006	14,00	140302001	36,42
UNC No 8 x 32	4,17	4,5	45	14	3,4	3,50			140301007	14,00	140302002	36,42
UNC No 10 x 24	4,83	6,0	50	16	4,9	3,90			140301008	14,00	140302003	36,42
UNC No 12 x 24	5,49	6,0	50	18	4,9	4,50			140301009	14,00	140302004	36,42
UNC 1/4 x 20	6,35	6,0	50	19	4,9	5,20	140101001	4,67	140301010	14,00	140302005	23,06
UNC 5/16 x 18	7,94	6,0	56	22	4,9	6,60	140101002	5,24	140301011	15,60	140302006	24,06
UNC 3/8 x 16	9,53	7,0	70	24	5,5	8,00	140101003	5,79	140301012	17,30	140302007	28,07
UNC 7/16 x 14	11,11	8,0	70	24	6,2	9,40	140101004	7,35	140301013	21,95	140302008	34,42
UNC 1/2 x 13	12,70	9,0	75	29	7,0	10,80	140101005	8,91	140301014	26,60	140302009	41,10
UNC 9/16 x 12	14,29	11,0	80	30	9,0	12,20	140101006	11,69	140301015	34,90	140302010	53,46
UNC 5/8 x 11	15,88	12,0	80	32	9,0	13,50	140101007	13,14	140301016	39,23	140302011	60,81
UNC 3/4 x 10	19,05	14,0	95	40	11,0	16,50	140101008	17,60	140301017	52,53	140302012	81,19
UNC 7/8 x 9	22,23	18,0	100	40	14,5	19,50	140101009	23,39	140301018	69,81	140302013	101,24
UNC 1" x 8	25,40	18,0	110	50	14,5	22,25	140101010	26,95	140301019	80,46	140302014	121,62
UNC 1.1/8 x 7	28,58	22,0	132	56	18,0	25,00			140301020	124,00		
UNC 1.1/4 x 7	31,75	22,0	132	56	18,0	28,25			140301021	139,63		
UNC 1.3/8 x 6	34,93	28,0	150	63	22,0	30,75			140301022	181,51		
UNC 1.1/2 x 6	38,10	32,0	150	63	24,0	34,00			140301023	209,43		
UNC 1.5/8 x 5	41,28	32,0	160	70	24,0	37,10			140301024	418,88		
UNC 1.3/4 x 5	44,45	36,0	160	70	29,0	39,50			140301025	418,88		
UNC 1.7/8 x 4,5	47,63	36,0	190	80	29,0	42,00			140301026	545,21		
UNC 2" x 4,5	50,80	40,0	190	80	32,0	45,00			140301027	545,21		
UNC 2.1/4 x 4,5	57,15	45,0	220	80	35,0	51,50			140301028	1357,20		
UNC 2.1/2 x 4	63,50	50,0	220	80	39,0	57,25			140301029	1809,57		
UNC 2.3/4 x 4	69,85	50,0	240	80	39,0	63,50			140301030	4524,11		
UNC 3" x 4	73,20	50,0	260	80	39,0	70,00			140301031	5567,83		

UNC

Unified coarse thread
ANSI B1.1

Tap for machine use in through hole.
The spiral point pushes the chips ahead.

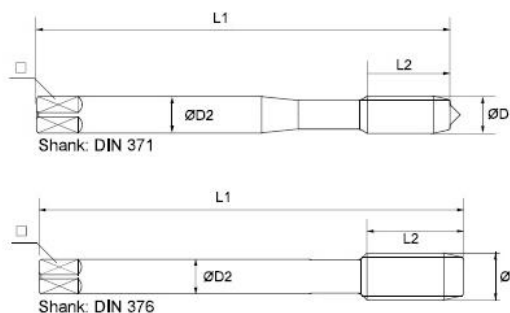

Machine Tap for general use

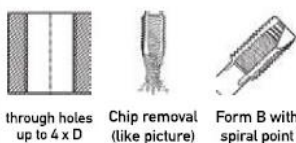

through holes up to 4 x D
Chip removal (like picture)
Form B with spiral point



material: HSSE 2B to 900 N/mm² 27.1 HRC



4-5 threads outside cooling and lubrication

Machine Tap for stainless steels

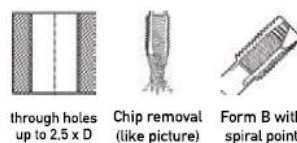

through holes up to 2.5 x D
Chip removal (like picture)
Form B with spiral point



material: HSSE-TiAlN 2B to 1300 N/mm² 41 HRC



4-5 threads outside cooling and lubrication

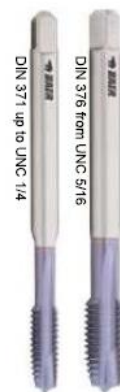

UNC

	D1	D2	L1	L2	□		No.	€	No.	€
DIN 371										
UNC No 2 x 56	2,18	2,8	45	8	2,1	1,85			140405001	57,75
UNC No 3 x 48	2,52	2,8	50	9	2,1	2,10			140405002	55,00
UNC No 4 x 40	2,85	3,5	50	10	2,7	2,30	140401001	9,58	140405003	35,52
UNC No 5 x 40	3,18	3,5	56	11	2,7	2,60	140401002	9,58	140405004	29,46
UNC No 6 x 32	3,51	4,0	56	12	3,0	2,85	140401003	9,58	140405005	29,46
UNC No 8 x 32	4,17	4,5	63	13	3,4	3,50	140401004	9,58	140405006	29,46
UNC No 10 x 24	4,83	6,0	70	15	4,9	3,90	140401005	9,58	140405007	30,24
UNC No 12 x 24	5,49	6,0	70	16	4,9	4,50	140401006	9,58	140405008	30,24
UNC 1/4 x 20	6,35	7,0	80	17	5,5	5,20	140401007	9,58	140405009	30,24
UNC 5/16 x 18	7,94	8,0	90	20	6,2	6,60	140401008	12,14		
UNC 3/8 x 16	9,53	9,0	100	22	7,0	8,00	140401009	13,58		
DIN 376										
UNC No 4 x 40	2,85	1,8	50	10	-	2,30	140401010	9,58		
UNC No 5 x 40	3,18	2,2	56	11	1,8	2,60	140401011	9,58		
UNC No 6 x 32	3,51	2,5	56	12	2,1	2,85	140401012	9,58		
UNC No 8 x 32	4,17	2,8	63	13	2,1	3,50	140401013	9,58		
UNC No 10 x 24	4,83	3,5	70	15	2,7	3,90	140401014	9,58		
UNC No 12 x 24	5,49	3,5	70	16	2,7	4,50	140401015	9,58		
UNC 1/4 x 20	6,35	4,5	80	17	3,4	5,20	140401016	9,58		
UNC 5/16 x 18	7,94	6,0	90	20	4,9	6,60	140401017	12,14	140405010	37,66
UNC 3/8 x 16	9,53	7,0	100	22	5,5	8,00	140401018	13,58	140405011	44,23
UNC 7/16 x 14	11,11	8,0	100	22	6,2	9,40	140401019	16,15	140405012	57,75
UNC 1/2 x 13	12,70	9,0	110	25	7,0	10,80	140401020	16,15	140405013	57,75
UNC 9/16 x 12	14,29	11,0	110	26	9,0	12,20	140401021	24,62	140405014	75,62
UNC 5/8 x 11	15,88	12,0	110	27	9,0	13,50	140401022	24,62	140405015	84,95
UNC 3/4 x 10	19,05	14,0	125	30	11,0	16,50	140401023	47,89	140405016	145,46
UNC 7/8 x 9	22,23	18,0	140	32	14,5	19,50	140401024	57,92	140405017	179,12
UNC 1" x 8	25,40	20,0	160	36	16,0	22,25	140401025	65,71	140405018	235,84
UNC 1,1/4 x 7	31,75	22,0	180	40	18,0	28,25	140401026	91,88		
UNC 1,1/2 x 6	38,10	32,0	200	50	24,0	34,00	140401027	191,56		
UNC 1,3/4 x 5	44,45	36,0	220	65	29,0	39,50	140401028	328,57		
UNC 2" x 4,5	50,80	40,0	250	70	32,0	45,00	140401029	474,47		

Machine Taps - Form C (with spiral flutes) for blind holes

UNC Unified coarse thread ANSI B1.1

Tap for machine use in blind holes.
The fast spiral flutes provide good chip removal from the blind hole.

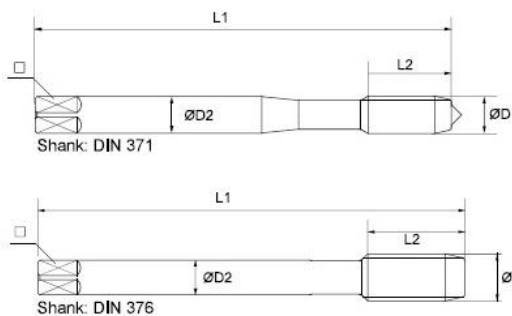

Machine Tap for general use

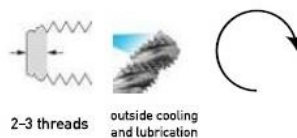
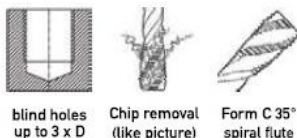

Machine Tap for stainless steels

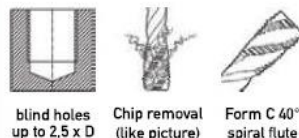

UNC	D1	D2	L1	L2	□		No.	€	No.	€
DIN 371										
UNC No 2 x 56	2,18	2,8	45	6	2,1	1,85			140605001	62,69
UNC No 3 x 48	2,52	2,8	50	7	2,1	2,10			140605002	56,49
UNC No 4 x 40	2,85	3,5	50	6	2,7	2,30	140601001	11,92	140605003	37,88
UNC No 5 x 40	3,18	3,5	56	7	2,7	2,60	140601002	11,92	140605004	31,83
UNC No 6 x 32	3,51	4,0	56	7	3,0	2,85	140601003	11,92	140605005	31,83
UNC No 8 x 32	4,17	4,5	63	8	3,4	3,50	140601004	11,92	140605006	31,83
UNC No 10 x 24	4,83	6,0	70	10	4,9	3,90	140601005	11,92	140605007	32,60
UNC No 12 x 24	5,49	6,0	70	10	4,9	4,50	140601006	11,92	140605008	32,60
UNC 1/4 x 20	6,35	7,0	80	13	5,5	5,20	140601007	11,92	140605009	32,60
UNC 5/16 x 18	7,94	8,0	90	14	6,2	6,60	140601008	14,93		
UNC 3/8 x 16	9,53	9,0	100	16	7,0	8,00	140601009	16,37		
DIN 376										
UNC No 4 x 40	2,85	1,8	50	10	-	2,30	140601010	11,92		
UNC No 5 x 40	3,18	2,2	56	11	1,8	2,60	140601011	11,92		
UNC No 6 x 32	3,51	2,5	56	12	2,1	2,85	140601012	11,92		
UNC No 8 x 32	4,17	2,8	63	13	2,1	3,50	140601013	11,92		
UNC No 10 x 24	4,83	3,5	70	15	2,7	3,90	140601014	11,92		
UNC No 12 x 24	5,49	3,5	70	16	2,7	4,50	140601015	11,92		
UNC 1/4 x 20	6,35	4,5	80	17	3,4	5,20	140601016	11,92		
UNC 5/16 x 18	7,94	6,0	90	20	4,9	6,60	140601017	14,93	140605010	40,03
UNC 3/8 x 16	9,53	7,0	100	22	5,5	8,00	140601018	16,37	140605011	46,59
UNC 7/16 x 14	11,11	8,0	100	22	6,2	9,40	140601019	20,16	140605012	60,11
UNC 1/2 x 13	12,70	9,0	110	25	7,0	10,80	140601020	20,16	140605013	60,11
UNC 9/16 x 12	14,29	11,0	110	26	9,0	12,20	140601021	29,73	140605014	77,98
UNC 5/8 x 11	15,88	12,0	110	27	9,0	13,50	140601022	29,73	140605015	87,31
UNC 3/4 x 10	19,05	14,0	125	30	11,0	16,50	140601023	59,26	140605016	147,82
UNC 7/8 x 9	22,23	18,0	140	32	14,5	19,50	140601024	72,39	140605017	181,48
UNC 1" x 8	25,40	20,0	160	36	16,0	22,25	140601025	81,31	140605018	238,20
UNC 1,1/4 x 7	31,75	22,0	180	40	18,0	28,25	140601026	103,58		
UNC 1,1/2 x 6	38,10	32,0	200	50	24,0	34,00	140601027	226,09		
UNC 1,3/4 x 5	44,45	36,0	220	65	29,0	39,50	140601028	356,40		
UNC 2" x 4,5	50,80	40,0	250	70	32,0	45,00	140601029	505,64		

UNIForm Machine Forming Taps

UNC Unified coarse thread ANSI B1.1

Machine Forming Taps have following advantages:

- No chips
- Up to 20 times longer lifetime (compared to taps)
- Same forming tap for through and blind hole
- Wide range of materials can be processed
- Intersection of the thread is impossible
- Very high trueness
- Increased strength of the thread
- Higher surface quality
- Much higher cutting speed

Machine Forming Taps for universal use

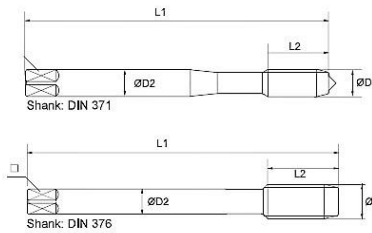
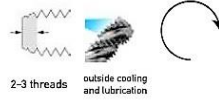
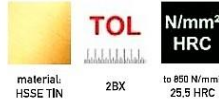
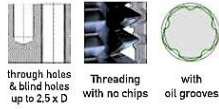

UNC	D1	D2	L1	L2	□	No.	€	
UNC No 4 x 40	2,85	3,5	56	11	2,7	2,55	141101001	*
UNC No 5 x 40	3,18	3,5	56	10	2,7	2,65	141101002	*
UNC No 6 x 32	3,51	4,0	56	12	3,0	3,15	141101003	*
UNC No 8 x 32	4,17	4,5	63	13	3,4	3,80	141101004	*
UNC No 10 x 24	4,83	6,0	70	15	4,9	4,35	141101005	*
UNC No 12 x 24	5,49	6,0	80	16	4,9	5,00	141101006	*
UNC 1/4 x 20	6,35	7,0	80	17	5,5	5,75	141101007	*
UNC 5/16 x 18	7,94	8,0	90	20	6,2	7,30	141101008	*
UNC 3/8 x 16	9,53	10,0	100	22	8,0	8,80	141101009	*
UNC 7/16 x 14	11,11	8,0	100	22	6,2	10,25	141101010	*
UNC 1/2 x 13	12,70	9,0	110	25	7,0	11,80	141101011	*
UNC 9/16 x 12	14,29	11,0	110	26	9,0	13,30	141101012	*
UNC 5/8 x 11	15,88	12,0	110	27	9,0	14,80	141101013	*
UNC 3/4 x 10	19,05	14,0	125	30	11,0	17,85	141101014	*

* on request

1/4" Combined-Bit-Taps

UNC Unified coarse thread ANSI B1.1

Efficient internal thread cutting with battery-powered screwdriver (min. 7,5 Volt). Core hole drilling and thread tapping in one fluent process.

Application: non abrasive material up to 600 N/mm² unalloyed and low alloyed steel

Kombi-Bit-Taps for through holes

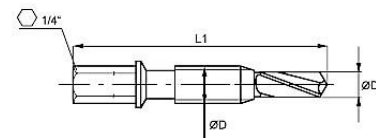
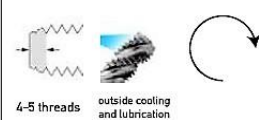
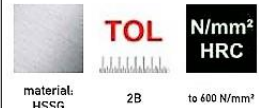
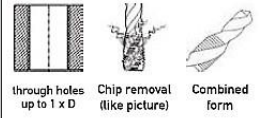

UNC	D1	D2	L1	□	No.	€
UNC No 4 x 40	2,85	2,3	36	1/4"	141301001	*
UNC No 5 x 40	3,18	2,6	36	1/4"	141301002	*
UNC No 6 x 32	3,51	2,9	39	1/4"	141301003	*
UNC No 8 x 32	4,17	3,5	39	1/4"	141301004	*
UNC No 10 x 24	4,83	3,9	41	1/4"	141301005	*
UNC No 12 x 24	5,49	4,5	41	1/4"	141301006	*
UNC 1/4 x 20	6,35	5,2	44	1/4"	141301007	*
UNC 5/16 x 18	7,94	6,6	50	1/4"	141301008	*
UNC 3/8 x 16	9,53	8,0	59	1/4"	141301009	*

* on request