



2601



Special torque tools

Angle disc

For angle controlled bolting

- to be used with a torque wrench
- flexible arm
- strong magnet

Artikel-Nr. Order-No.	Ident-Nr. Ident-No.		Winkel AA	Eingang Input	Ausgang Output	L	
2601	26018122000		0-360°	12.5 (1/2")	12.5 (1/2")	450	300



1/2" 3/4"

Item			Arm	Pitch	D mm	H mm	L mm	
11951195	1/2"	1/2"	Magnet	2°	67.0	63.0	480.0	170
11961196	1/2"	1/2"	Claw	2°	67.0	63.0	538.0	60
11971197	3/4"	3/4"	Magnet	2°	87.0	87.0	624.0	170
11981198	3/4"	3/4"	Claw	2°	87.0	87.0	698.0	60

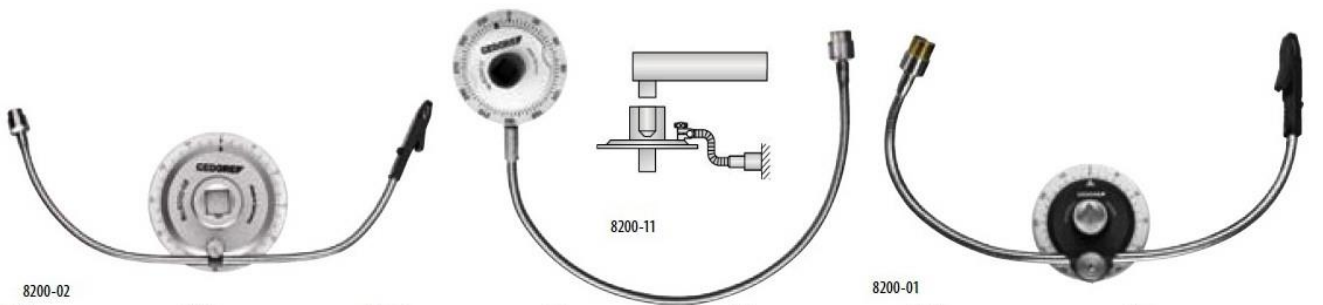

8200-02	8200-01						
		Ø mm	∠°		Code	No.	
1/2	1/2	80	0-360	0.330	1195980	8200-01	
1/2	1/2	82	0-360	0.330	7718480	8200-11	
3/4	3/4	120	0-360	0.530	7716510	8200-02	

Use:

» Additional angle-regulated tightening for controlled torque and angle activation

Features:

- » Torque angle indicator with 1/2" or 3/4" square drive
- » For additional precise angle tightening (0 - 360°)
- » 1/2" square drive with ball locking device or 3/4" square drive with pin locking device
- » No. 8200-01/-02 models with sliding magnetic and gripping arm
- » No. 8200-11 only with magnetic arm - simple design
- » To operate with a suitable torque wrench
- » The maximum output of the torque wrench must not be passed

Scope of delivery:

- » Torque angle indicator
- » Delivered in a strong plastic case (no. 8200-01/-02), model no. 8200-11 in sturdy hard cardboard packaging