



- Accurate to  $\pm 3\%$  of reading which meets the requirements of ISO6789-1:2017
- Unmistakable signal when set torque is reached
- High quality 72 tooth ratchet allows use in confined spaces
- Fixed head version has a push-through square for left and right handed torque tightening
- Moulded grip aids correct hand location and operator comfort

2	ADJUSTABLE RATCHET - DUAL SCALE
11123	SLO, $\frac{1}{4}$ " 4 - 20 N-m, 40 - 180 lbf-in
11087	SLO, $\frac{3}{8}$ " 4 - 20 N-m, 40 - 180 lbf-in



2	ADJUSTABLE - FIXED HEAD - DUAL SCALE
11125	SLO, $\frac{3}{8}$ " Fixed Head, 4 - 20 N-m, 40 - 180 lbf-in



2	TORQUE HANDLE ADJUSTABLE - DUAL SCALE
11126	SLO 16mm spigot, 4 - 20 N-m, 40 - 180 lbf-in
11122	SLO 9 x 12mm female, 4 - 20 N-m, 40 - 180 lbf-in



Production 'P' type versions are designed to discourage unauthorised alteration. They have no scale and so must be set against a torque testing device such as Norbar's TruCheck™ - see page 78.

2	PRODUCTION 'P' TYPE (Must be set using a Torque Tester, see pages 76-83)
11089	SLO $\frac{3}{8}$ " Fixed Head, 1 - 20 N-m, 10 - 180 lbf-in
11085	SLO $\frac{1}{4}$ " 1 - 20 N-m, 10 - 180 lbf-in
11086	SLO $\frac{3}{8}$ " 1 - 20 N-m, 10 - 180 lbf-in
11090	SLO 16mm spigot, 1 - 20 N-m, 10 - 180 lbf-in
11088	SLO 9 x 12mm female, 1 - 20 N-m, 10 - 180 lbf-in
SQ2222	Pre-set, etch and certify (Allow 3 days delivery for this service)

SLO Ratchet

Model	SLO $\frac{1}{4}$ "	SLO $\frac{3}{8}$ "
Part Number/s	11123 11085	11087 11086
Dimensions (mm)	A	219
	B	204
	C	146
	ØD	30
	E	26
	F	19
Weight (Kg)	0.4	0.4

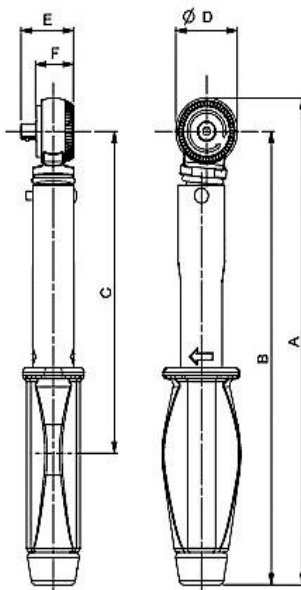

SLO Spigot Torque Handle

Model	SLO Spigot	
Part Number/s	11126 11090	
Dimensions (mm)	A	206
	B	199
	C	143
	ØD	16
Weight (Kg)	0.4	

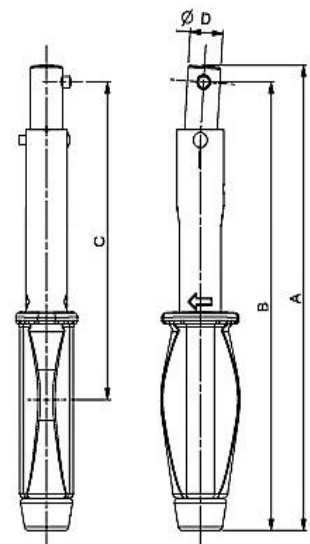

# SLIMLINE™ TORQUE WRENCHES



## SLO Fixed Head

Model	SLO 3/4" Fixed Head
Part Number/s	11125 11089
Dimensions (mm)	A 213
	B 203
	C 145
	D 19
	E 30
	F 17
Weight (Kg)	0.4

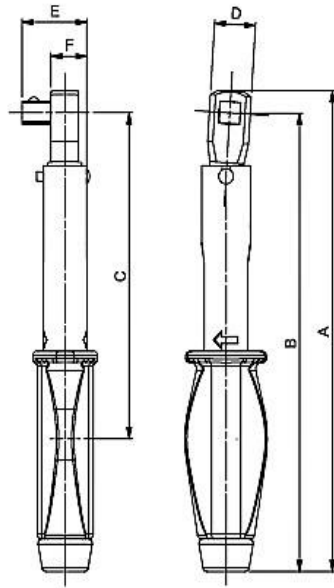

## SLO Female Torque Handle

Model	SLO FTH
Part Number/s	11122 11088
Dimensions (mm)	A 205
	B 194
	C 135
	D 22
	E 20
Weight (Kg)	0.4

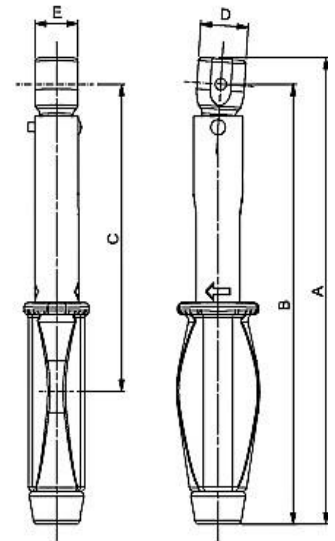

# PROFESSIONAL TORQUE WRENCHES MODEL 5



The Model 5 is a unique torque wrench that offers the convenience of interchangeable 1/4" hexagon bits. (ISO 1173:2001 Form C drive bits).

- Accuracy meets the requirements of ISO6789-1:2017
- Non-length dependent. The Model 5 remains accurate regardless of hand position
- Supplied in a storage case. The case allows space for the storage of additional drive bits, and optional stepless ratchet

Also available as Production 'P' Types, preventing unauthorised alteration of torque setting. No external calibration equipment is required to set the Model 5 'P' Type.

2	ADJUSTABLE
13001	Pro 5, 1/4" female hex, 1 - 5 N-m
13002	Pro 5, 1/4" female hex, 10 - 50 lbf-in
13003	Pro 5, 1/4" female hex, 10 - 50 kgf-cm

8	MODEL 5 ACCESSORY
13122	Stepless Ratchet 1/4" female hex

Model	Adjustable	'P' Type
Part Number/s	13001 13002 13003	13004 13005 13006
Dimensions (mm)	A 165	157
	B 155	147
	C 102	102
	D 18	18
	E 25	25
	F 13	13
	G 3	3
Weight (Kg)	0.12	0.12

8	MODEL 5 SPARES
28900	1/4" Hex 1/4" male square drive

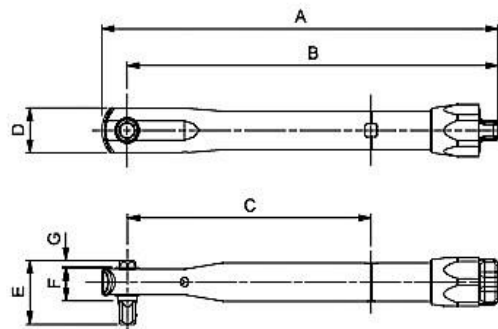

Model 5 'P' Type in storage case