

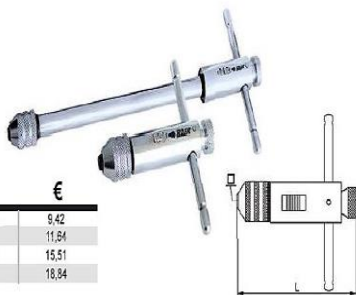

**DESANDADORES DE MACHOS**

**Holding Tools**

**BAER Tap holders with ratchet**



for taps		inch-sizes	pipe-threads	L1	No.	€
1	M 3 - M 10	1/8 - 3/8	2,4 - 5,5	85	491623001	9,42
2	M 5 - M 12	7/32 - 1/2	4,5 - 8,0	100	491623002	11,84
10	M 3 - M 10	1/8 - 3/8	2,4 - 5,5	250	491623010	15,51
20	M 5 - M 12	7/32 - 1/2	4,5 - 8,0	300	491623020	18,84

**Adjustable Tap Wrenches - zinc die cast**

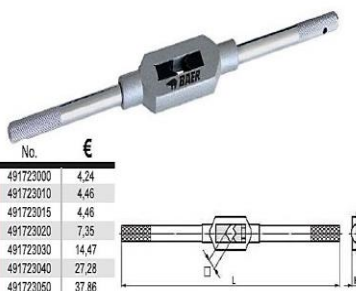

for taps		inch-sizes	pipe-threads	L1	No.	€	
0	M 1 - M 8	1/16 - 1/4		2,0 - 5,0	130	491723000	4,24
1	M 1 - M 10	1/16 - 3/8	G 1/8	2,0 - 6,3	176	491723010	4,46
1,1/2	M 1 - M 12	1/16 - 1/2	G 1/8	2,1 - 8,0	176	491723015	4,46
2	M 4 - M 12	5/32 - 1/2	G 1/8	3,0 - 9,0	280	491723020	7,35
3	M 5 - M 20	7/32 - 3/4	G 1/8 - G 1/2	4,9 - 12	380	491723030	14,47
4	M 11 - M 27	7/16 - 1"	G 1/4 - G 3/4	5,5 - 16	505	491723040	27,28
5	M 13 - M 32	1/2 - 1,1/4	G 1/4 - G 1"	7,0 - 20	700	491723050	37,86

**Adjustable Tap Wrenches - steel**

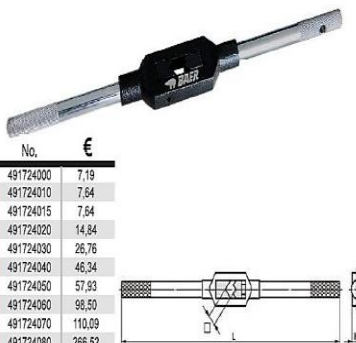

for taps		inch-sizes	pipe-threads	L1	No.	€	
0	M 1 - M 8	1/16 - 1/4		2,0 - 5,0	130	491724000	7,19
1	M 1 - M 10	1/16 - 3/8		2,0 - 6,3	180	491724010	7,64
1,1/2	M 1 - M 12	1/16 - 1/2	G 1/8	2,1 - 8,0	205	491724015	7,64
2	M 4 - M 12	5/32 - 1/2	G 1/8	3,0 - 9,0	280	491724020	14,84
3	M 5 - M 20	7/32 - 3/4	G 1/8 - G 1/2	4,9 - 12	380	491724030	26,76
4	M 11 - M 27	7/16 - 1"	G 1/4 - G 3/4	5,5 - 16	500	491724040	46,34
5	M 13 - M 32	1/2 - 1,1/4	G 1/4 - G 1"	7,0 - 20	700	491724050	57,93
6	M 18 - M 42	3/4 - 1,1/2	G 1/2 - G 1,1/4	11 - 24	1000	491724060	98,50
7	M 27 - M 52	1,1/8 - 2"	G 3/4 - G 1,3/4	16 - 32	1250	491724070	110,09
8	M 27 - M 64	1,1/8 - 3"	G 3/4 - G 3"	16 - 40	1250	491724080	266,52

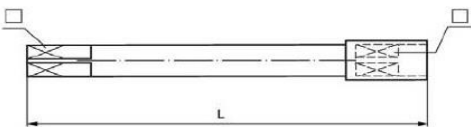

**Extension sleeves for taps**

□	L1	for taps metric acc. to DIN 352	No.	€
2,1	60	M 1 - M 2,6	491925021	3,37
2,4	70		491925024	3,37
2,7	80	M 3	491925027	3,37
3,0	90	M 3,5	491925030	3,37
3,4	95	M 4	491925034	3,37
3,8	100		491925038	4,05
4,3	105		491925043	4,73
4,9	110	M 4,5 - M 8	491925049	3,83
5,5	115	M 9 - M 10	491925055	4,28
6,2	120	M 11	491925062	4,61
7,0	125	M 12	491925070	5,73
8,0	125		491925080	7,08
9,0	130	M 14 - M 16	491925090	7,87
10,0	140		491925100	10,36
11,0	150	M 18	491925110	12,38
12,0	155	M 20	491925120	16,20
13,0	165		491925130	18,34
14,5	175	M 22 - M 24	491925145	22,50
16,0	180	M 27	491925160	23,63
18,0	200	M 30	491925180	27,79
20,0	220	M 33	491925200	36,00
22,0	220	M 36	491925220	49,62
24,0	235	M 39 - M 42	491925240	65,25
26,0	250		491925260	84,37
29,0	265	M 45 - M 48	491925290	99,01
32,0	285	M 52	491925320	140,63

**GRADES PARA CAÇONETES**

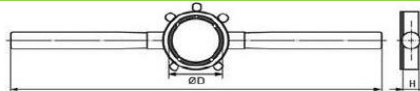

**Die Stocks - zinc die cast**

Ø D x H	For Round Dies		L1	No.	€
	metric	inch-sizes			
15 x 5	M 1 - M 2,6	BSW 1/16 - BSW 3/32	160	491823001	3,34
20 x 5	M 3 - M 4	BSW 1/8 - BSW 5/32	200	491823002	3,34
20 x 7	M 4,5 - M 6	BSW 3/16 - BSW 1/4	200	491823003	3,34
25 x 9	M 7 - M 9	BSW 5/16	224	491823004	4,12
30 x 11	M 10 - M 11	BSW 3/8 - BSW 7/16	280	491823005	6,57
38 x 10	MF 12 - MF 15	G 1/4	315	491823006	10,80
38 x 14	M 12 - M 14	BSW 1/2 - BSW 9/16	315	491823007	10,80
45 x 14	MF 16 - MF 20	G 3/8 - 1/2	450	491823008	13,25
45 x 18	M 16 - M 20	BSW 5/8 - BSW 13/16	450	491823009	13,25
55 x 16	MF 22 - MF 26	G 5/8 - G 3/4	560	491823010	17,49
55 x 22	M 22 - M 24	BSW 7/8 - BSW 1"	560	491823011	17,49
65 x 18	MF 27 - MF 36	G 7/8 - G 1"	630	491823012	24,50
65 x 25	M 27 - M 36	BSW 1,1/8 - BSW 1,3/8	630	491823013	24,50

Ø D in inch	For Round Dies		L1	No.	€
	Ø D (mm) x H (mm)	Ø D (inch) x H (inch)			
13/16"	20,6 x 6,35	13/16 x 1/4	200	491823014	3,34
1"	25,4 x 9,5	1" x 3/8	224	491823015	4,12
1,5/16"	33,4 x 11,1	1,5/16 x 7/16	270	491823016	7,02
1,1/2"	38,1 x 12,7	1,1/2 x 1/2	315	491823017	10,58
2"	50,8 x 15,9	2" x 5/8	560	491823018	17,26
2,1/4"	57,1 x 17,5	2,1/4 x 11/16	560	491823019	17,48
2,1/2"	63,5 x 19,0	2,1/2 x 3/4	630	491823020	24,50
3"	76,2 x 22,2	3" x 7/8	900	491823021	67,94
3,1/2"	88,9 x 25,4	3,1/2" x 1"	900	491823022	70,16
4"	101,6 x 25,4	4" x 1"	1000	491823023	212,72

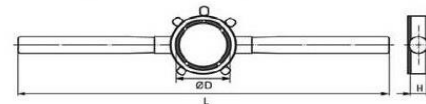

AÇO

**Die Stocks - steel**

Ø D x H	For Round Dies		L1	No.	€
	metric	inch-sizes			
45 x 18	M 16 - M 20	BSW 5/8 - BSW 13/16	450	491824001	25,49
55 x 22	M 22 - M 24	BSW 7/8 - BSW 1"	560	491824002	35,92
65 x 25	M 27 - M 36	BSW 1,1/8 - BSW 1,3/8	630	491824003	45,20
75 x 20	MF 38 - MF 42	G 1,1/8 - G 1,1/4	800	491824004	74,15
75 x 30	M 38 - M 42	BSW 1,1/2 - BSW 1,5/8	800	491824005	74,15
90 x 22	MF 45 - MF 52	G 1,3/8 - G 1,5/8	900	491824006	95,02
90 x 36	M 45 - M 52	BSW 1,3/4 - BSW 2"	900	491824007	95,02
105 x 22	MF 54 - MF 63	G 1,3/4 - G 2"	975	491824008	113,55
105 x 36	M 54 - M 63	BSW 2,1/4	975	491824009	113,55
120 x 22	MF 64 - MF 71	G 2,1/4 - G 2,3/4	956	491824010	324,44
120 x 36	M 64 - M 71	BSW 2,1/2 - BSW 2,3/4	956	491824011	324,44
130 x 25		G 3"	966	491824012	405,55
130 x 36			966	491824013	405,55
140 x 22			976	491824014	521,44
150 x 25		G 3,1/2"	986	491824015	551,31
160 x 25		G 4"	996	491824016	757,38

**3131A** Adjustable Tap Holder



3131A	□	Stem		L1	Ø D	Ø H
		Min	Max			
1	1/8"	2,0	5,0	42	30	5
2	3/8"	4,5	9,0	47	100	5

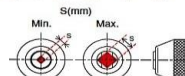

**160K** Reversible Flusher



160K	□	Ø	L1	L2	Ø D	Ø H
160K-12	10	220	135	1		

**3132** Die Holder



3132	□	S	Ø	L1	L2	L3	L4	L5	L6	Ø D	Ø H
3132-30	25	34	14	22	9	42	60	130	2		

**4132** Die Holder



Die is not included. Diehalter nicht enthalten. Fibre non inclus.