



## BORING HEAD

### CARACTERÍSTICAS

Capacidad: 4-200 mm  
 Expansión máxima del carro: 21 mm  
 Alojamiento de los portacuchillas: Ø16 mm  
 Alojamiento transversal para cuchilla: 12 × 12 mm  
 Precisión: ±0,02 mm Ø

### SPECIFICATIONS

Capacity: 4-200 mm  
 Maximum travel: 21 mm  
 Bore for tool-holder: Ø16 mm  
 Transverse slot for blade: 12 × 12 mm  
 Accuracy: ±0,02 mm Ø



Código Code	Referencia Reference	Conexión mediante Portafresas estándar Ø22mm con arrastre según DIN 138 Ø22mm Standard coupling with shell mill arbors and driving slots according to DIN 138	Kg
03010100	UM 200N-CM3-S	Morse 3 DIN 228	5,4
03010200	UM 200N-CM4-S	Morse 4 DIN 228	5,7
03010300	UM 200N-CM5-S	Morse 5 DIN 228	7,0
03010400	UM 200N-CI30-S	ISO 30 DIN 2080	5,4
03010500	UM 200N-CI40-S	ISO 40 DIN 2080	5,6
03010600	UM 200N-CI40-S	ISO 40 DIN 69871	6,2
03010700	UM 200N-CBT40-S	MAS 403 BT 40	6,0
03010900	UM 200N-CI50-S	ISO 50 DIN 2080	5,6

Medidas en mm / Dimensions in mm

### PORTAPLACAS / TOOLHOLDERS

Código Code	Referencia Reference	Dimensiones (mm) Sizes (mm)	Tipo de inserto Insert type	Ø min mecanizable Min. achievable Ø
03030100	UM200N-P7.28	Ø 6,6 × 28	TCMT06T102	8
03030200	UM200N-P9.37	Ø 8,75 × 37	TCMT06T102	10
03030300	UM200N-P10.42	Ø 10 × 42	TCMT090204	12
03030400	UM200N-P16.54	Ø 15,8 × 54	TCMT090204	18
03030500	UM200N-P22.80	Ø 22 × 80	TCMT110204	26

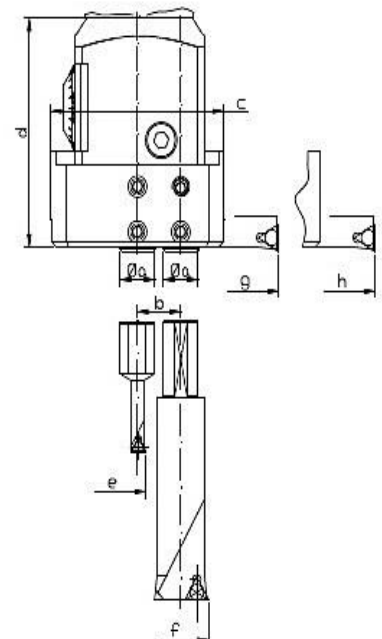

Øa	b	c	d	e	f	g	h
20mm	20mm	80mm	91mm	~ 3,5=26mm	~ 66mm	~150mm	~200mm

Boring head sets

**NEU  
NEW** !



**Typ AKS 2G, Ausdrehbereich Ø 10 mm - 240 mm**  
**Type AKS 2G, boring capacity Ø 10 mm - 240 mm**

- Skala 0,01 mm
- Lieferumfang: Ausdrehkopf, 4 Bohrstangen, 1 Ausdrehwerkzeug, je 1 Sechskantschlüssel 3, 4 und 6 mm
- scale 0,01 mm
- scope of delivery: boring head, 4 boring bars, 1 boring tool, one each hexagon wrenches 3, 4 and 6 mm

Schaft / Shank	Bohrtiefe max. / Depth max. mm	kg	Art.-Nr. / Order no.
BT 40	120	6	● BAS-AKS2G-BT40
DIN 69871 / SK 40	120	6,5	● BAS-AKS2G-SK40
MK / MT 3	120	7,5	● BAS-AKS2G-MK3
MK / MT 4	120	7	● BAS-AKS2G-MK4



**Typ AKS 1, Ausdrehbereich Ø 8 mm - 46 mm**  
**Type AKS 1, boring capacity Ø 8 mm - 46 mm**

- Skala 0,005 mm
- Gesamt-Vorschub: 6 mm
- Lieferumfang: Ausdrehkopf, 8 Bohrstangen Ø 16 mm, Befestigungsschrauben, Bedienschlüssel
- scale 0,005 mm
- total stroke: 6 mm
- scope of delivery: boring head, 8 boring bars Ø 16 mm, screws, setting tool

Schaft / Shank	Bohrtiefe max. / Depth max. mm	kg	Art.-Nr. / Order no.
BT 40	90	7	○ 09-AKS1-BT40
BT 50	90	8	○ 09-AKS1-BT50
DIN 69871 / SK 40	90	7	● 09-AKS1-SK40
DIN 69871 / SK 50	90	8	○ 09-AKS1-SK50



**Typ AKS 2, Ausdrehbereich Ø 8 mm - 280 mm**  
**Type AKS 2, boring capacity Ø 8 mm - 280 mm**

- Skala 0,005 mm
- Gesamt-Vorschub: 27 mm
- Lieferumfang: Ausdrehkopf, 8 Bohrstangen Ø 20 mm, Befestigungsschrauben, Bedienschlüssel
- scale 0,005 mm
- total stroke: 27 mm
- scope of delivery: boring head, 8 boring bars Ø 20 mm, screws, setting tool

Schaft / Shank	Bohrtiefe max. / Depth max. mm	kg	Art.-Nr. / Order no.
BT 40	115	8	● 09-AKS2-BT40
BT 50	115	10	○ 09-AKS2-BT50
DIN 69871 / SK 40	115	8	● 09-AKS2-SK40
MK / MT 3	115	7	● 09-AKS2-MK3
MK / MT 4	115	7	○ 09-AKS2-MK4
MK / MT 5	115	8	○ 09-AKS2-MK5

**Passende Wendeschneidplatten**  
**Suitable inserts**

AKS 2G Ausdrehbereich / Boring capacity	AKS 1 Ausdrehbereich / Boring capacity	AKS 2 Ausdrehbereich / Boring capacity	Wendeschneidplatten / Inserts	Art.-Nr. / Order no.
Ø 10 - 240 mm	Ø 8 - 13 mm	Ø 8 - 13 mm	TBGT060102L	● 1M-TBGT060102L
-	Ø 12 - 15 mm	Ø 12 - 21 mm	TPGH090204L	○ 1M-TPGH090204L
-	Ø 16 - 46 mm	Ø 20 - 280 mm	TPGH110304L	● 1M-TPGH110304L