



Registos Reguladores de Caudal Circulares

PRODUTO

RRI

- > Para regulação do caudal de ar dentro da conduta
- > Diâmetro desde 80 até 800 mm
- > Atuação manual ou motorizada
- > Construção em aço galvanizado estilo IRIS
- > Ligação Spiro

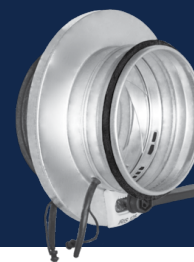

DIMENSÕES

| $\varnothing d_1$ | $\varnothing D$ | L [mm] | A [mm] | B [mm] |
|-------------------|-----------------|--------|--------|--------|
| 80 | 125 | 110 | 30 | 22 |
| 100 | 165 | 110 | 30 | 32 |
| 125 | 188 | 110 | 30 | 32 |
| 150 | 230 | 210 | 40 | 40 |
| 160 | 230 | 110 | 30 | 35 |
| 200 | 285 | 110 | 30 | 42 |
| 250 | 335 | 135 | 40 | 42 |
| 315 | 410 | 135 | 40 | 47 |
| 400 | 525 | 190 | 60 | 62 |
| 500 | 655 | 170 | 50 | 77 |
| 630 | 815 | 170 | 50 | 92 |
| 800 | 1015 | 270 | 100 | 107 |

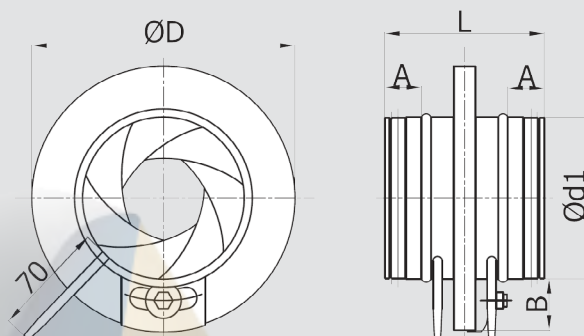

PERDA DE CARGA E VELOCIDADE

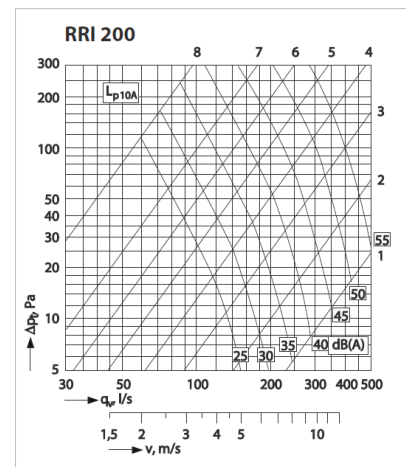
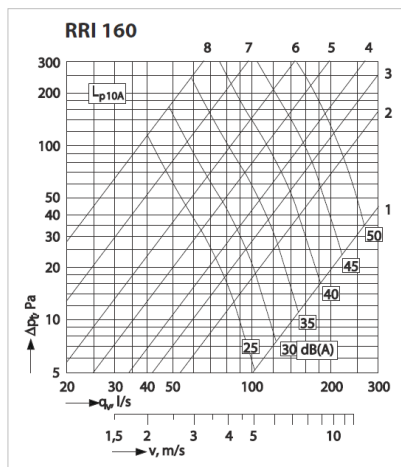
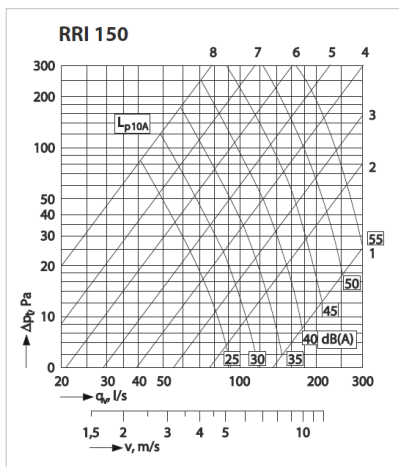
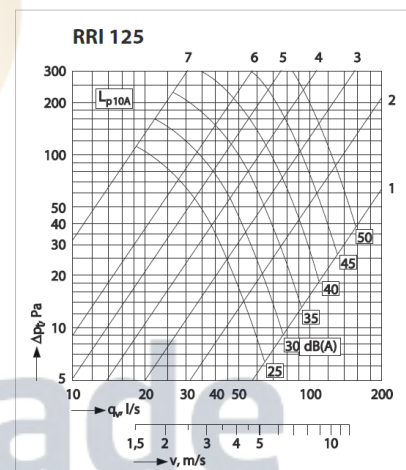
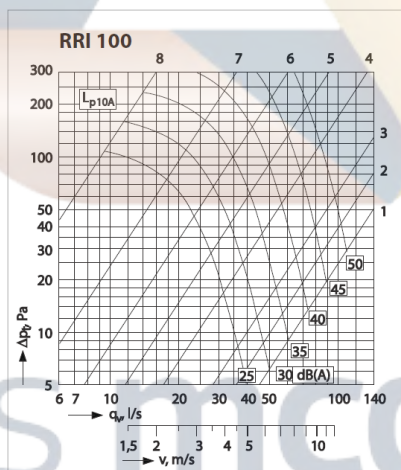
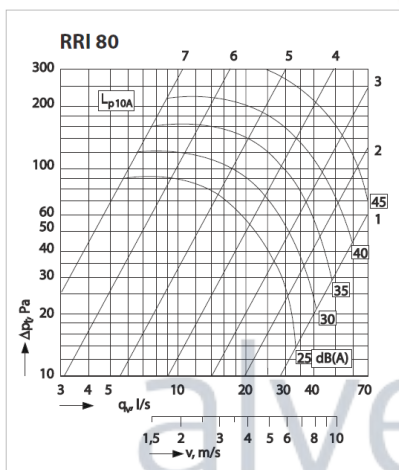



PERDA DE CARGA E VELOCIDADE

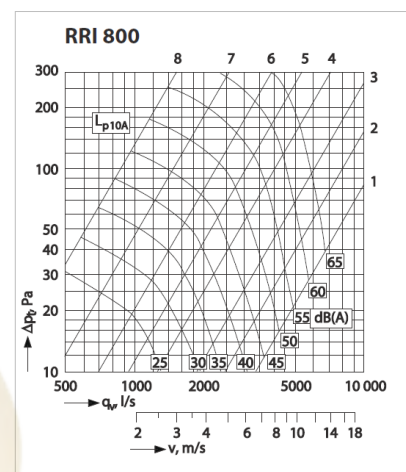
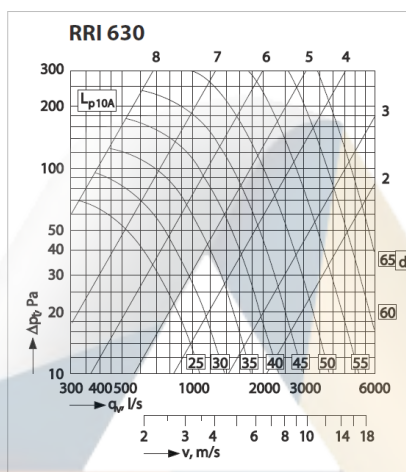
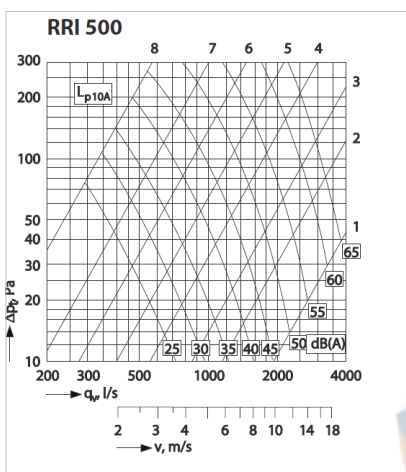
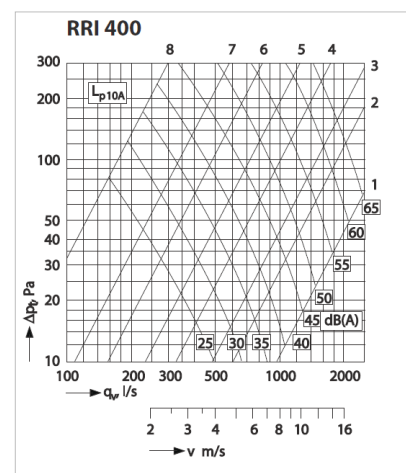
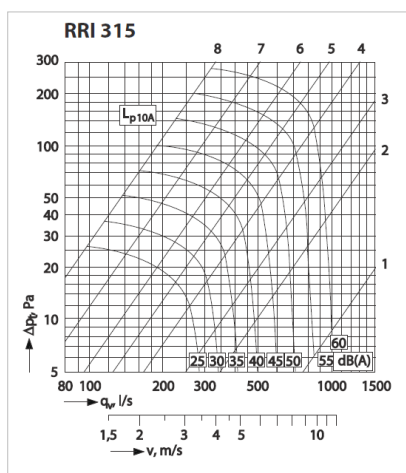
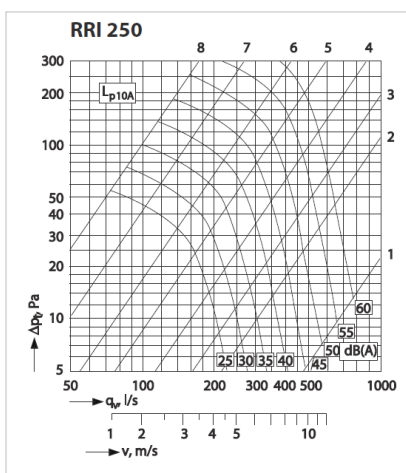

alves mcdade